

**ACCESS TO AND MOVEMENT  
WITHIN BUILDINGS, AND  
PROTECTIVE BARRIERS**





# Contents

---

## INTRODUCTION

## REGULATION 32

Access to and movement within buildings, and protective barriers

## THE STANDARDS

<b>S1</b>	Application of Part S	<i>S1.1-S1.3</i>
<b>S2</b>	Access to and movement within buildings	
	Car parking	<i>S2.1-S2.2</i>
	Access to buildings	<i>S2.3</i>
	Principal entrance	<i>S2.4-S2.5</i>
	Movement within buildings	<i>S2.6-S2.7</i>
	Internal doors and lobbies	<i>S2.8-S2.9</i>
	Areas of audience and spectator fixed seating	<i>S2.10</i>
<b>S3</b>	Stairs and ramps	
	General standards for all stairs	<i>S3.1</i>
	Rules of measurement	<i>S3.2</i>
	Rise, going and pitch of a flights in stairs	<i>S3.3-S3.9</i>
	Length of flights	<i>S3.10</i>
	Risers and nosings	<i>S3.11</i>
	Flights consisting partly of straight and partly of tapered treads	<i>S3.12-S3.14</i>
	Flights consisting wholly of tapered treads	<i>S3.15</i>
	Pedestrian ramps	<i>S3.16-S3.17</i>
	Landings	<i>S3.18-S3.19</i>
	Handrails	<i>S3.20-S3.24</i>
	Headroom	<i>S3.25</i>
	Industrial stairs and fixed ladders	<i>S3.26</i>
	Stairs and fixed ladders in agricultural buildings	<i>S3.27</i>
	Steps in sloping gangways	<i>S3.28</i>
<b>S4</b>	Protective barriers	
	Pedestrian protective barriers	<i>S4.1-S4.3</i>
	Vehicle protective barriers	<i>S4.4-S4.5</i>

## PROVISIONS DEEMED TO SATISFY THE STANDARDS

<b>(S2.3)</b>	Access to buildings
<b>(S2.5)</b>	Principal entrance
<b>(S2.6-S2.7)</b>	Movement within buildings
<b>(S3.10)</b>	Rise, going and pitch of stairs
<b>(S3.11)</b>	Risers and nosings
<b>(S3.12)</b>	Flights consisting partly of straight and partly of tapered treads
<b>(S3.15)</b>	Flights consisting wholly of tapered treads
<b>(S3.26)</b>	Industrial stairs and fixed ladders
<b>(S3.27)</b>	Stairs and fixed ladders in agricultural buildings
<b>(S4.3)</b>	Pedestrian protective barriers
<b>(S4.5)</b>	Vehicle protective barriers

## ASTERISKS

Throughout the Technical Standards an asterisk against a standard denotes that a provision deemed to satisfy the standard or some aspect of the standard is specified at the end of the relevant Part.

## ITALICS

Throughout the Technical Standards a term in italics is a defined term. The definition is listed in Part A, General.



## Introduction

---

- 1.** The intention of this Part is to ensure, as far as is *reasonably practicable*, that *buildings* are accessible to all users including *disabled people* who should be able to gain access to and within *buildings* without assistance. There are provisions to ensure that those who have impaired sight can enter and move within *buildings*.
- 2.** It should be noted that relevant material from the now deleted Part T has been incorporated in this Part.
- 3.** All stairs, ramps and protective barriers forming part of a *building* must incorporate the basic criteria of safety, which are -
  - a.** that stair and ramp design must be within limits recognised as offering safe passage; and
  - b.** that protective barriers are designed to reduce the risk of injury from falling to a lower level and to protect people from vehicles, where vehicles have access to a *building*.
- 4.** The use of an industrial stair or fixed ladder is permitted in certain circumstances.
- 5.** A number of issues relating to good practice have not been included as being inappropriate to a document concerned with minimum standards. Designers may nevertheless find it helpful to refer to the “Access Guide”, published by Disability Scotland, and the “Guidance on the Use of Tactile Paving Surfaces”, published jointly by The Scottish Office and the Department for the Environment, Transport and the Regions.
- 6.** The “Guide to Safety at Sports Grounds” provides further guidance on steps or ramps associated with gangways of shallow pitch in assembly *buildings* (*purpose sub-group 5B*) such as sports stadia, arenas, theatres and cinemas.
- 7.** Where there is a *storey* accessible to *disabled people* with fixed seating for spectators or an audience, spectators in wheelchairs should be able to sit next to able-bodied or disabled companions.
- 8.** In this Part the term *disabled people* always includes wheelchair users.
- 9.** This Part is limited to the provision of access into and within *buildings*. It does not cover means of escape in the event of fire, for which reference should be made to Part E.
- 10.** Other legislation has a bearing on access, and in particular due regard should be taken of the provisions and supporting guidance of the Disability Discrimination Act 1995 and the Workplace (Health, Safety and Welfare) Regulations 1992.

## Regulation 32

### Access to and movement within *buildings*, and protective barriers

- 32.** (1) All users of a *building* shall be provided with adequate means of access, and adequate means of movement within the *building* both horizontally and vertically.
- (2) A *building* which contains fixed seating accommodation for an audience or spectators shall be provided with adequate level spaces for wheelchairs.
- (3) Except where -
- (a) the provision of protective barriers would obstruct the use of such areas; or
  - (b) in terms of the *Technical Standards*, such provision is not necessary,
- every stair, ramp, raised floor or other raised accessible area which forms part of a *building* or which is provided to meet a requirement of this regulation shall have a suitable protective barrier.
- (4) Paragraphs (1) and (2) shall not be subject to specification in a notice served under section 11 of *the Act*.

## The standards

---

### S1 Application of Part S

---

- S1.1** This Part sets out the required standards for Regulation 32.
- S1.2** The standards apply to all *buildings*,  
except -
- the standards in S2 do not apply to *buildings* of *purpose group* 1.
- S1.3** Standards S3.26 to S3.28 do not apply to access for *disabled people*.

---

### S2 Access to and movement within *buildings* other than *dwelling*s

---

#### CAR PARKING

- S2.1** Where car parking is provided within land in the same occupation as a *building* to which this standard applies, parking spaces in accordance with S2.2 must be -
- a. provided at a ratio at least one car parking space per 20 parking spaces or part thereof; and
  - b. not more than 45 metres from the principal entrance of the *building*; and
  - c. clearly marked for use by *disabled people*.
- S2.2** A car parking space or spaces must each be at least 4.8 x 2.4 metres with a clear space at least 1 metre wide along one long side. The clear space may be shared between 2 car parking spaces.

#### ACCESS TO BUILDINGS

- S2.3\*** The approach to the principal entrance of a *building* from a point of access to, and from any car parking within, land in the same occupation, must have -
- a. a level or ramped firm surface suitable for *disabled people*; and
  - b. an unobstructed width of at least 1.2 metres, unless a handrail is required by this Part, in which case the width at handrail level may reduce to at least 1 metre; and
  - c. a dropped kerb between any road, or car parking provided for *disabled people*, and the access route to the *building*.

#### PRINCIPAL ENTRANCE

- S2.4** The principal entrance door must -
- a. contain a leaf which provides a clear opening width of at least 800 mm in accordance with the diagram to this standard; and

**S2.4 – S2.6**

- b. have an unobstructed space on the side next to the leading edge of at least 300mm, in accordance with the diagram to this standard, **except -**
  - where the door is opened by automatic control; and
- c. have a clear *glazed* panel or panels giving a zone of visibility from a height of not more than 900mm to at least 1.5 metres above finished floor level; and
- d. where it comprises a revolving door, be provided with an adjacent side hinged or automatic door complying with a. to c.

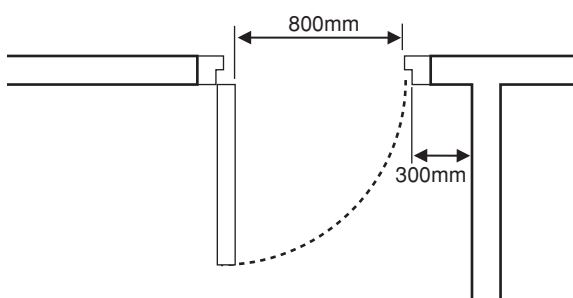
**Diagram to S2.4: Principal entrance**

**S2.5\*** Where an entrance lobby is provided it must be sized to -

- a. permit a wheelchair user to move clear of one door before using the next; and
- b. allow for someone assisting the wheelchair user; and
- c. permit an able-bodied person to pass.

**MOVEMENT WITHIN BUILDINGS**

**S2.6\*** Access for *disabled people* must be provided to and throughout each *storey* of a *building*, **except -**

- a. to a *storey* containing only fixed plant or machinery the only normal visits to which are intermittent to inspect or maintain the fixed plant or machinery; or
- b. to any catwalk, racking or openwork floor; or
- c. to a *storey*, other than the principal entrance *storey*, or *gallery* in a *building* of not more than 2 *storeys* where the *storey* or *gallery* is not more than 280 square metres in area excluding vertical circulation, *sanitary accommodation* and plant rooms; or
- d. to a *storey*, other than the principal entrance *storey*, or *gallery* in a *building* of more than 2 *storeys* where the *storey* or *gallery* is not more than 200 square metres in area excluding vertical circulation, *sanitary accommodation* and plant rooms; or
- e. to a bedroom not having access to *sanitary facilities* suitable for *disabled people* in accordance with Part M, in a *building* of *purpose sub-group* 2B not provided with a lift; or



- f. within an area having fixed seating where wheelchair spaces and associated access are provided in accordance with S2.10; or
- g. in a car park and parking garage of *purpose sub-group 7B or 7C, storeys* where car parking for *disabled people* is not provided; or
- h. to more than half the public area of a restaurant or bar, provided there is access to the counter in a bar and to any self-service counter in a restaurant.

**S2.7\*** A change of level within a *storey* to which access for *disabled people* is required by S2.6 must be accomplished by a -

- a. ramp; or
- b. stair, together with a means of providing unassisted movement between levels for wheelchair users.

### INTERNAL DOORS AND LOBBIES

**S2.8** An internal door accessible to *disabled people* must -

- a. contain a leaf which provides a clear opening width of at least 750mm; and
- b. have an unobstructed space on the side next to the leading edge of at least 300mm in accordance with the diagram to this standard, **except -**  
  - where the door is opened by automatic control; and
- c. where the door is across a corridor or passageway, have a clear *glazed* panel or panels giving a zone of visibility from a height of no more than 900mm to at least 1.5 metres above finished floor level.

**Diagram to S2.8: Internal doors**

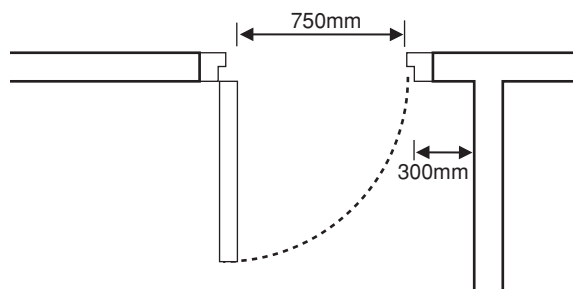

**S2.9** An internal lobby accessible to *disabled people* must comply with S2.5.

**S2.10, S3.1****AREAS OF AUDIENCE AND SPECTATOR FIXED SEATING**

**S2.10** In an accessible *storey* which contains fixed seating for spectators, or an audience, accessible level spaces for wheelchair users must be provided in accordance with the table to this standard and which -

- a. are each at least 1.4 metres x 900mm; and
- b. are dispersed among the remainder of the seating; and
- c. enable wheelchair users to be located next to able-bodied or disabled companions; and
- d. are arranged to avoid the extra height of wheelchair users from obstructing sightlines; and
- e. are kept clear specifically for wheelchair users or are fitted with seating which can be readily removed if the space is required for a wheelchair user.

---

**Table to S2.10: Wheelchair space provision in areas of audience and spectator fixed seating**

---

Seated capacity	Number of wheelchair spaces
up to 200	2
201-10 000	2 + 1 per 100 above 200
10 001-20 000	100 + 5 per 1 000 above 10 000
20 001-40 000	150 + 3 per 1 000 above 20 000
more than 40 000	210 + 2 per 1 000 above 40 000

---



---

## **S3** Stairs and ramps

---

**GENERAL STANDARDS FOR ALL STAIRS**

**S3.1** A stair must be *constructed* in any of the following ways -

- a. a straight *flight* in accordance with S3.2 to S3.11;
- b. a *flight* consisting partly of straight and partly of *tapered treads* in accordance with S3.2 to S3.8, and S3.10 to S3.14;
- c. a *flight* consisting wholly of *tapered treads* in accordance with S3.6 to S3.8, and S3.15;
- d. an industrial stair or fixed ladder in accordance with S3.26;
- e. a stair or fixed ladder in an *agricultural building* in accordance with S3.27;
- f. a stair forming part of a sloping gangway in a *building of purpose group 5* in accordance with S3.28.

**RULES OF MEASUREMENT**

**S3.2** The rise and going must be measured in accordance with the diagram to this standard -

**Diagram to S3.2: Stair measurement**

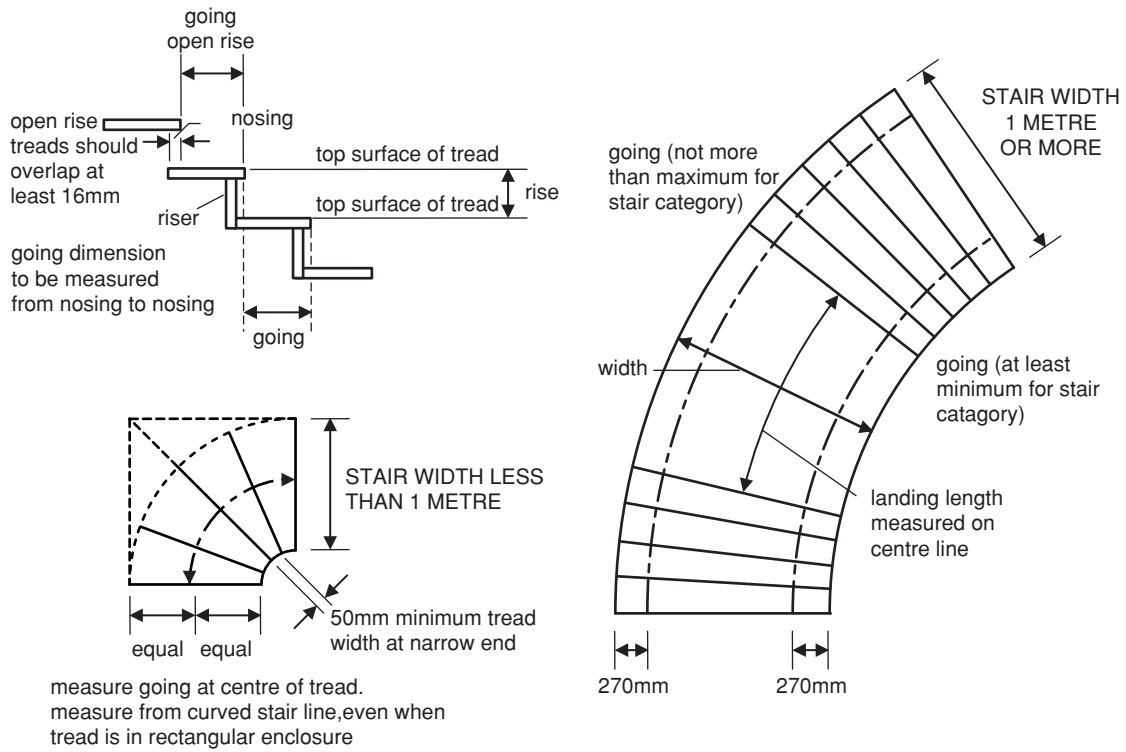

**Note:**

1. The number of *tapered treads* shown is indicative only.

**RISE, GOING AND PITCH OF FLIGHTS IN STAIRS**

**S3.3** The maximum rise, minimum going and pitch of *flights* in stairs must be in accordance with the table to this standard -

**Table to S3.3: Rise, going and pitch of flights in stairs**

Description of stair	Maximum rise (mm)	Minimum going (mm) [Note 1]	Maximum pitch
1. Private stair	220	225	42° [Note 2]
2. Any other stair	170	250	34°

**Note:**

1. In the case of *tapered treads*, subject to S3.12 to S3.14.
2. The combination of maximum rise and minimum going will result in a pitch steeper than this.

**S3.4 – S3.10**

**S3.4** The width of a stair, measured between handrails and clear of obstructions, must be at least 1 metre, **except -**

- a. the width of a *private stair* may reduce to at least -
  - i. 900mm where it is within the accessible *storey*, or
  - ii. 600mm where it serves only *sanitary accommodation* and/or one *room*, other than a living *room* or *kitchen*, or
  - iii. 800mm elsewhere; and
- b. stringers and newels may each project not more than 30mm into the width; and
- c. a stair lift projecting into the width may be fitted to a stair within a *dwelling*.

**Note:**

There are additional stair width requirements for *escape stairs* in Part E.

**S3.5** The aggregate of the going and twice the rise must be at least 550mm and not more than 700mm.

**S3.6** A *flight* must have uniform rises, each at least 75mm.

**S3.7** The depth of a tread must not be less than the going.

**S3.8** In a *flight* with open rises the treads must overlap by at least 16mm. Any opening between adjacent treads in a *flight* in a *building of purpose group 1 or 5 or purpose sub-group 2A* must be small enough to prevent the passage of a 100mm sphere.

**S3.9** In a straight *flight*, or in that part of a *flight* which is straight, the going measured along the centre line of the *flight* must be uniform.

**LENGTH OF FLIGHTS**

**S3.10** A *flight* must have -

- a. not more than 16 rises; and
- b. at least 3 rises, **except -**

there may be less than 3 rises -

  - i. between an external door of a *building* and the ground, balcony, *conservatory*, *porch* or private garage; or
  - ii. in a stepped ramp; or
  - iii. wholly within an *apartment* within a *dwelling*; or
  - iv. wholly within *sanitary accommodation* within a *dwelling*; or
  - v. between a landing and an adjoining level where the route of travel from the adjoining level to the next *flight* changes direction through 90 degrees.

**RISERS AND NOSINGS**

**S3.11\*** A stair serving a *storey* to which access for *disabled people* is required by S2.6 must have -

- a. risers profiled to minimise tripping; and
- b. nosings distinguishable through contrasting colour or tone.

**Note:**

This standard does not apply to a *private stair* in a *dwelling*.

**FLIGHTS CONSISTING PARTLY OF STRAIGHT AND PARTLY OF TAPERED TREADS**

**S3.12\*** In that part of a *flight* consisting of *tapered treads*, the going of the *tapered treads* must be uniform and must not be less than the going of the straight treads. At the inner end of the tread the going must be at least 50mm.

**S3.13** In a *flight* less than 1 metre wide the going must be measured at the centre line of the *flight* as in S3.2.

**S3.14** In a *flight* 1 metre wide or more the going must be measured at the two points 270mm from each end of the tread as in S3.2 and the minimum going must be at least the going of the straight treads.

**FLIGHTS CONSISTING WHOLLY OF TAPERED TREADS**

**S3.15\*** A *flight* consisting wholly of *tapered treads* must be *constructed* so as to give safe passage. The requirements in S3.18 to S3.25 for landings, so far as they apply to intermediate landings between floors, and for handrails, and for headroom, do not apply to such stairs.

**PEDESTRIAN RAMPS**

**S3.16** The maximum gradient and maximum length of a *flight* of a ramp for use by pedestrians must be in accordance with the table to this standard -

**Table to S3.16: Gradient and length of a *flight* in a ramp**

Gradient of <i>flight</i>	Maximum length of <i>flight</i>
not more than 1 in 20	No limit
not more than 1 in 15	10m
not more than 1 in 12	5m
more than 1 in 12	not permitted

**S3.17** A ramp must have -

- a. a width at least the minimum required for the equivalent type of stair in S3.4; and
- b. a raised kerb at least 100mm high on any exposed side of a *flight* or landing, **except -**
  - a ramp serving a single *dwelling*.

**S3.18 – S3.22****LANDINGS**

**S3.18** A landing, level except for any necessary slope for drainage, must be provided at the top and bottom of every *flight* of a stair or ramp,  
**except -**

- a. a landing may be common to two or more *flights*; and
- b. a landing is not required to a *flight* between the external door of -
  - i. a *building* and the ground, balcony, *conservatory*, *porch* or private garage, where the door slides or opens in a direction away from the *flight* and the aggregate rise is not more than 600mm; or
  - ii. a *dwelling* or private garage ancillary to a *dwelling* and the ground, balcony, *conservatory*, or *porch*, other than a door required to be accessible for *disabled people* under Part Q, where the change in level is not more than 170mm.

**S3.19** The unobstructed length of a landing, measured along its centre line and clear of any door swing, must be at least 1.2 metres,  
**except -**

- a. in a *dwelling*, the length of a landing may reduce to at least 900 mm; and
- b. a door may open onto a landing between *flights* such that at any angle of swing it does not diminish the effective width of the landing to less than the width of the stair or ramp; and
- c. a door may open onto the bottom landing of a *flight* such that at any angle of swing a clear length of at least 400 mm is left across the full width of the landing.

**HANDRAILS**

**S3.20** A stair or ramp for a change in level of more than 600mm, or a ramp longer than 2 metres, must have a handrail on both sides of every *flight*,  
**except -**

- a. no handrail is required on a ramp serving a single dwelling where the change of level is no more than 600mm; and
- b. a *private stair* in a *dwelling* connecting two or more *storeys* may have a handrail on only one side.

**S3.21** A stair or ramp more than 1.8 metres wide must be divided by a handrail, or handrails, in such a way that each section is at least 1.1 metres and not more than 1.8 metres wide,  
**except -**

- a. a stair or ramp serving a single *dwelling*; or
- b. a stair between an entrance door to a *building* and ground level which does not form part of an *escape route*.

**S3.22** A handrail must be fixed at a height of at least 840mm and not more than 1 metre, measured vertically above the pitch line of the *flight* or surface of the landing.

**S3.23** A handrail must extend at least 300mm beyond the top and bottom of a *flight* and have a profile and projection that allows a firm grip.  
**except -**

where the handrail serves a single *dwelling*.

**S3.24** The ends of a handrail must be wreathed when not forming part of a protective barrier,  
**except -**

where the handrail serves a single *dwelling*.

### HEADROOM

**S3.25** A stair, ramp or landing must have a clear headroom of at least 2 metres extending over the whole of the width, measured vertically from the pitch line of the *flight* or the surface of the landing, as shown in the diagram to this standard -

**Diagram to S3.25: Measuring headroom**

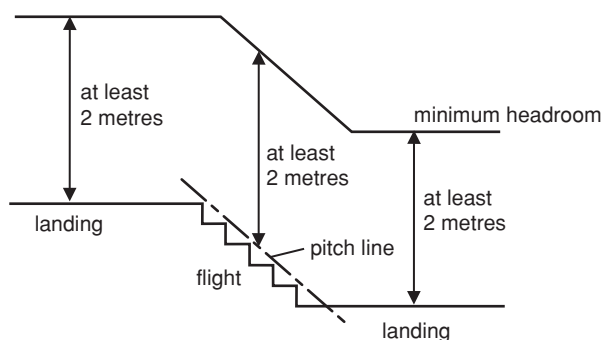

### INDUSTRIAL STAIRS AND FIXED LADDERS

**S3.26\*** An industrial stair or fixed ladder serving areas requiring limited access in any *building* must be *constructed* so as to offer safe passage.

### STAIRS AND FIXED LADDERS IN AGRICULTURAL BUILDINGS

**S3.27\*** A stair or fixed ladder in an *agricultural building* must be *constructed* so as to offer safe passage.

### STEPS IN SLOPING GANGWAYS

**S3.28** In a *building of purpose group 5* where steps form part of sloping gangways serving areas for audiences or spectators each step must have a rise at least 125mm and not greater than 190mm.

## S4 Protective barriers

### PEDESTRIAN PROTECTIVE BARRIERS

**S4.1** A protective barrier for pedestrians must be provided at the edge of -

- a. every floor, stair, ramp, raised floor or other raised accessible area where there is a difference in level of 600mm or more; and
- b. a landing where the route of travel from the adjoining level to the next *flight* changes direction through 90 degrees,
  - except -**
    - i. where the barrier would be incompatible with normal use, such as a loading bay or stage; or
    - ii. where a wall, partition or fixed *glazing* at the edge of a drop in level meets the requirement of S4.3.

**S4.2** In a *building of purpose group 1 or 5 or purpose sub-group 2A* openings in a protective barrier must be small enough to prevent the passage of a 100mm diameter sphere,
   
**except -**

the space between a rise and the lowest edge of the protective barrier may be larger if the lowest edge is not more than 50 mm above, and parallel to, the pitch line of a stair or ramp.

**S4.3\*** A protective barrier must be -

- a. secure; and
- b. capable of resisting appropriate loads; and
- c. of a height at least that given in the table to this standard -

**Table to S4.3: Height of pedestrian protective barriers**

Location	Minimum height (mm)
At the edge of a floor in front of walls, partitions, fixed <i>glazing</i> and opening windows	800
On a <i>flight</i> within or serving a single <i>dwelling</i>	840
In front of or behind fixed seating	800 [Note 1]
On (a) a stair or ramp; or (b) a <i>gallery</i> or raised area within a single <i>dwelling</i>	900
Elsewhere	1100 [Note 2]

**Notes:**

1. The protective barrier may be reduced to 750 mm where it has an overall width at the top of at least 250 mm.
2. Where a handrail forming the top of a protective barrier to a *flight* meets a protective barrier to a landing, the height of the latter may be reduced for a distance not more than 300 mm to permit a smooth junction.



**VEHICLE PROTECTIVE BARRIERS**

**S4.4** A barrier to provide protection from vehicles must be provided at the edge of a drop in level in every floor, roof or ramp which is accessible to vehicles, and forms part of a *building*.

**S4.5\*** A vehicle protective barrier provided in accordance with S4.4 must be capable of resisting appropriate loads and be of a height at least that given in the table to this standard -

---

**Table to S4.5: Height of vehicle protective barriers**

---

<b>Location</b>	<b>Minimum height (mm)</b>
Floor or roof edge	400
Ramp edge	600

---

## Provisions deemed to satisfy the standards

### ACCESS TO BUILDINGS

(S2.3) The requirements of S2.3 as regards a firm surface suitable for *disabled people* will be met by -

- a. 50mm concrete slabs bedded on granular material; or
- b. 30mm tarmacadam to BS4987: Parts 1 and 2: 1993 laid on 100 mm of consolidated hardcore bottoming; or
- c. 50mm clay or calcium silicate pavers to BS6677: Part 1: 1986, laid in accordance with BS6677: Part 2: 1986; or
- d. 60mm concrete paving blocks to BS 6717: Part 1: 1993, laid in accordance with BS6677: Part 2: 1986.

### PRINCIPAL ENTRANCE

(S2.5) The requirements of S2.5 will be met by a lobby complying with any of the examples in the diagram to this specification -

Diagram to (S2.5): Entrance lobbies

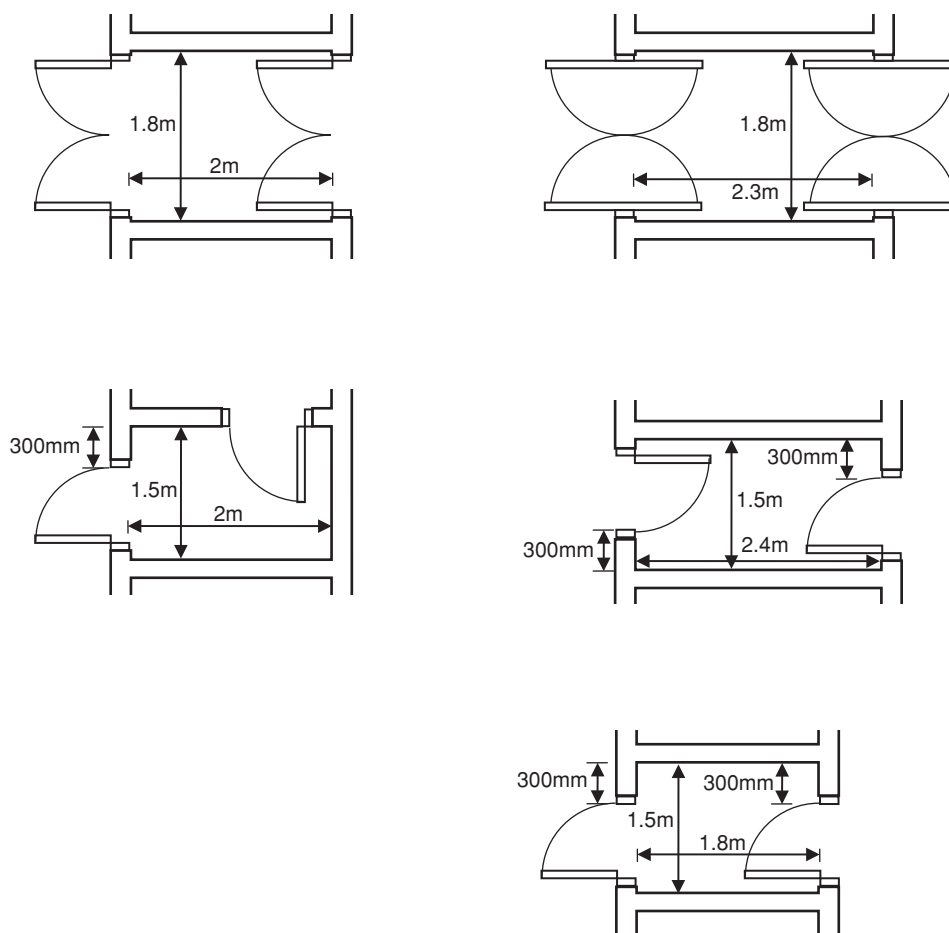

**Note:**

Doors to lobbies must have a clear opening width of at least 800 mm.

**MOVEMENT WITHIN BUILDINGS**

**(S2.6)** The requirements of S2.6 for provision of access to *storeys* above or below the principal entrance *storey* will be met by -

- a. a passenger lift having -
- i. a clear landing at least 1.5 x 1.5 metres in front of the lift entrance door or doors, and
  - ii. lift door or doors with a clear opening width of at least 800mm, and
  - iii. a lift car at least 1.1 x 1.4 metres, and
  - iv. within the lift car a horizontal rail on 3 sides, or on 2 sides if the lift car has 2 doors, 900mm above the floor; and
  - v. controls outside sited between 900mm and 1.2 metres above the landing, and within the lift car on a side wall between 900mm and 1.2 metres above the car floor and at least 400mm from the corner, and
  - vi. tactile call buttons, and visual and tactile indication of the *storey* level, on each *storey* served, and
  - vii. within the lift car, tactile *storey* selector buttons and, in a lift serving more than 2 *storeys*, visual and voice indicators of the *storey* reached, and
  - viii. a signalling system which gives 5 seconds notification that the lift is answering a landing call, and a dwell time of 5 seconds before the lift doors close after they are fully open, **except -**  
  
the dwell time may be reduced to 3 seconds where the door closing system is over-ridden by a door re-activating device which relies on photo-eye or infra-red methods, but not a door edge pressure system; or
- b. in the case of exceptions c. and d. of S2.6, by a stair.

**(S2.7)** The requirements of S2.7b. will be met by a wheelchair platform stairlift in accordance with BS5776: 1996, or a powered lifting platform in accordance with BS6440: 1983.

**RISERS AND NOSINGS**

**(S3.11)** The requirements of S3.11b. will be met by rises profiled in accordance with the diagram to this specification -

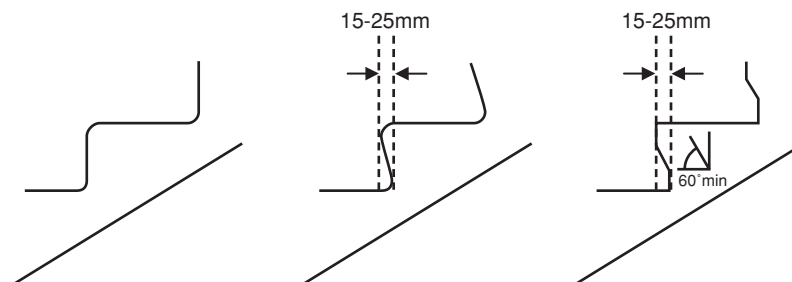
**Diagram to (S3.11): Step profile examples**

**(S3.12) – (S4.5)****FLIGHTS CONSISTING PARTLY OF STRAIGHT AND PARTLY OF TAPERED TREADS**

**(S3.12)** The requirements of S3.12 as regards *tapered treads* will be met where the stair is *constructed* in accordance with BS585: Part 1: 1989, Appendices B1 and B3, irrespective of the material of *construction* or whether it contains open rises.

**FLIGHTS CONSISTING WHOLLY OF TAPERED TREADS**

**(S3.15)** The requirements of S3.15 will be met where the *flight* consists wholly of *tapered treads* forming a helix or spiral and is *constructed* in accordance with BS5395: Part 2: 1984. Where such a *flight* forms an *escape stair* the category of the stair must be in accordance with the table to this specification -

---

**Table to (S3.15): Helical or spiral flights forming an escape stair**

---

Appropriate capacity not exceeding - [Note 1]	Stair category [Note 2]
10	B
25	C [Note 3]
50	D [Note 3]
100	E [Note 3]

---

**Notes:**

1. Appropriate capacity to be calculated in accordance with Part E.
2. Refer to Table 2 of BS 5395: Part 2: 1984.
3. Handrails must be provided on both sides.

**INDUSTRIAL STAIRS AND FIXED LADDERS**

**(S3.26)** The requirements of S3.26 will be met by the use of industrial stairs or fixed ladders in the circumstances described in, and *constructed* in accordance with, BS5395: Part 3: 1985; or BS4211: 1994; or by a Type A Spiral or Helical Stair *constructed* in accordance with BS5395: Part 2: 1984.

**STAIRS AND FIXED LADDERS IN AGRICULTURAL BUILDINGS**

**(S3.27)** The requirements of S3.27 will be met by the use of stairs or fixed ladders in the circumstances described in, and *constructed* in accordance with, BS5502: Part 80: 1990.

**PEDESTRIAN PROTECTIVE BARRIERS**

**(S4.3)** The requirements of S4.3 will be met where the loads are calculated in accordance with BS6399: Part 1: 1996.

**VEHICLE PROTECTIVE BARRIERS**

**(S4.5)** The requirements of S4.5 will be met where the loads are calculated in accordance with BS6399: Part 1: 1996.