

STYLE:

design

techne

skin

fontanot®  
scale di ogni tempo



[http:// www.technestairs.com](http://www.technestairs.com)



## Techne Tools

[www.technestairs.com/tools](http://www.technestairs.com/tools)

### Stair Planner



### Augmented Reality



Copyright by Fontanot S.p.A., first publication 25 January 2012

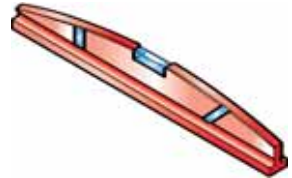
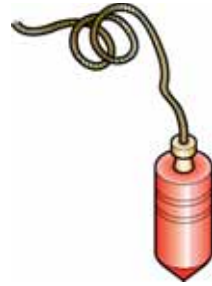
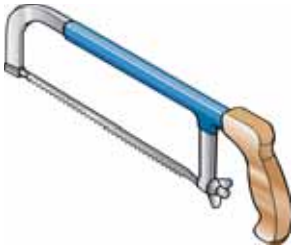

13 mm      17 mm

2 mm      5 mm  
2.5 mm      6 mm  
3 mm      12 mm  
4 mm



PH 2

1,2 x 8 mm



30 mm

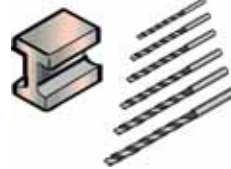

Ø 2,5 mm      Ø 6 mm  
Ø 3 mm      Ø 8,5 mm  
Ø 4 mm      Ø 16 mm

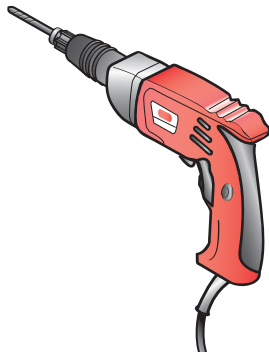

Ø 8 x 300 mm  
Ø 14 x 150 mm

Ø 10 mm      Ø 30 mm  
Ø 13 mm



1

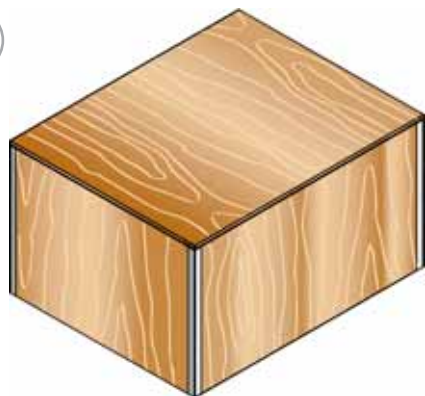

2

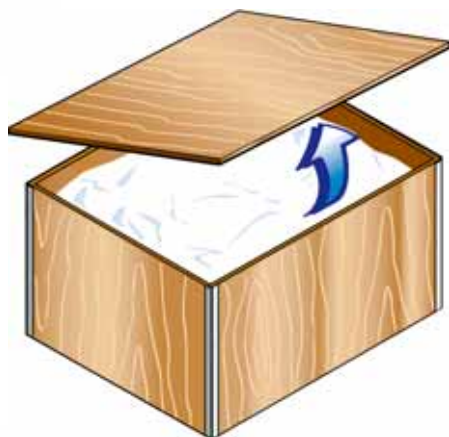

3

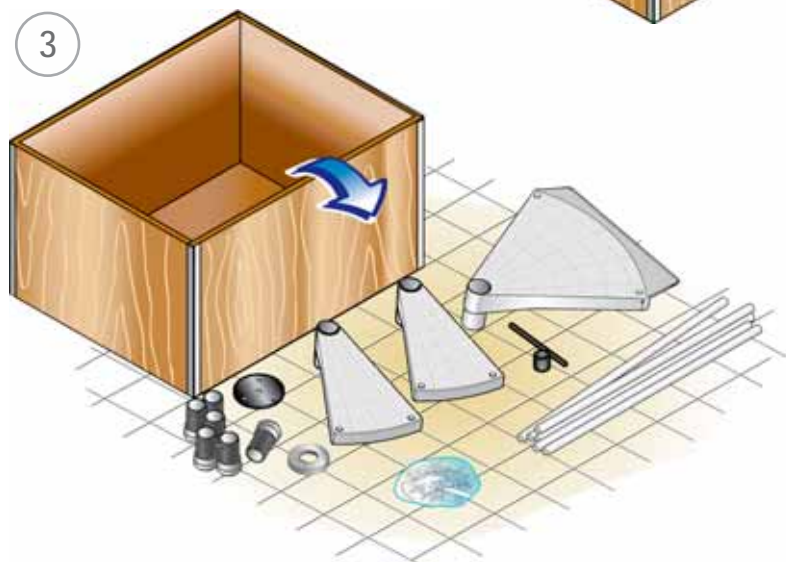

10	11	12	13	14	15	16
1	2	2	4	4	4	

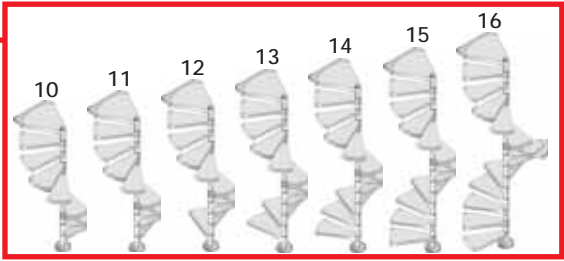

A21 ↔ A37



10	11	12	13	14	15	16
4	4	4	4	4	4	4

A22



10	11	12	13	14	15	16
4	4	5	5	5	6	6

A23



10	11	12	13	14	15	16
1	1	1	1	1	1	1

A24 ↔ A36



10	11	12	13	14	15	16
1	1	1	1	1	1	1

A27



10	11	12	13	14	15	16
17	18	19	20	21	22	23

A38



10	11	12	13	14	15	16
18	20	22	24	26	28	30

B03



10	11	12	13	14	15	16
1	1	1	1	1	1	1

B04



10	11	12	13	14	15	16
1	1	1	1	1	1	1

B05



10	11	12	13	14	15	16
1	1	1	1	1	1	1

B11



10	11	12	13	14	15	16
∅ 130	7	7	7	7	7	7
∅ 150	7	7	7	7	7	7
∅ 170	10	10	10	10	10	10

B12



10	11	12	13	14	15	16
∅ 130	11	11	11	11	11	11
∅ 150	11	11	11	11	11	11
∅ 170	14	14	14	14	14	14

B13



10	11	12	13	14	15	16
3	3	3	3	3	3	3

**B17**

10	11	12	13	14	15	16
1	1	1	1	1	1	1

**B23**

10	11	12	13	14	15	16
5	5	5	5	5	5	5

**B27**

10	11	12	13	14	15	16
2	2	2	2	2	2	2

**B33**

10	11	12	13	14	15	16
3	3	4	4	4	5	5

**B36**

10	11	12	13	14	15	16
∅ 130	2	2	2	2	2	2
∅ 150	2	2	2	2	2	2
∅ 170	3	3	3	3	3	3

**B37**

10	11	12	13	14	15	16
∅ 130	2	2	2	2	2	2
∅ 150	2	2	2	2	2	2
∅ 170	3	3	3	3	3	3

**B46**

10	11	12	13	14	15	16
2	2	2	2	2	2	2

**B47**

10	11	12	13	14	15	16
1	1	1	1	1	2	2

**B58**

10	11	12	13	14	15	16
2	2	2	2	2	2	2

**B89**

10	11	12	13	14	15	16
3	3	3	3	3	3	3

**BA1**

10	11	12	13	14	15	16
3	3	3	3	3	3	3

**BA2**

10	11	12	13	14	15	16
4	4	4	4	4	4	4

**BA3**

10	11	12	13	14	15	16
5	5	5	5	5	5	5

**BA4**

10	11	12	13	14	15	16
8	8	8	8	8	8	8

**BA5**

10	11	12	13	14	15	16
3	3	3	3	3	3	3

**BA6**

10	11	12	13	14	15	16
2	2	2	2	2	2	2

**BA8**

10	11	12	13	14	15	16
2	2	2	2	2	2	2

**BA9**

10	11	12	13	14	15	16
8	8	8	8	8	8	8

**BB7**

10	11	12	13	14	15	16
16	16	16	16	16	16	16

**BC3**

10	11	12	13	14	15	16
20	22	24	26	28	30	32

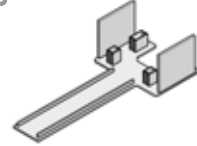
**BC4**

10	11	12	13	14	15	16
2	2	2	2	2	2	2

**BC5**

10	11	12	13	14	15	16
2	2	2	2	2	2	2

**BC6**

10	11	12	13	14	15	16
8	8	8	8	8	8	8

**BC7**

10	11	12	13	14	15	16
34	36	38	40	42	44	46

**BC9**

10	11	12	13	14	15	16
8	8	8	8	8	8	8

**BD3**

10	11	12	13	14	15	16
1	1	1	1	1	1	1

**BD5**

10	11	12	13	14	15	16
17	18	19	20	21	22	23

**BD6**

10	11	12	13	14	15	16
10	11	12	13	14	15	16

**BD8**

10	11	12	13	14	15	16
1	1	1	1	1	1	1

**BE1**

10	11	12	13	14	15	16
4	4	4	4	4	4	4

**BE2**

10	11	12	13	14	15	16
8	8	8	8	8	8	8

**BF6**

10	11	12	13	14	15	16
17	18	19	20	21	22	23

**C13**

10	11	12	13	14	15	16
20	22	24	26	28	30	32

**C29**

	10	11	12	13	14	15	16
Ø 130	6	6	6	6	6	6	6
Ø 150	6	6	6	6	6	6	6
Ø 170	9	9	9	9	9	9	9

**C31**

10	11	12	13	14	15	16
14	14	14	14	14	14	14

**C64**

10	11	12	13	14	15	16
40	42	44	46	48	50	52

**C79**

10	11	12	13	14	15	16
17	18	19	20	21	22	23

**C84**

10	11	12	13	14	15	16
2	2	2	2	2	2	2

**C85**

10	11	12	13	14	15	16
2	2	2	2	2	2	2

**C99**

10	11	12	13	14	15	16
10	11	12	13	14	15	16

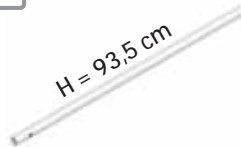
**CA4**

10	11	12	13	14	15	16
6	6	6	6	6	6	6

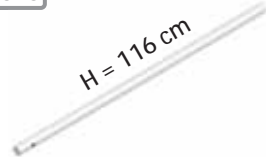
**CA5**

10	11	12	13	14	15	16
11	12	13	14	15	16	17

**CB3**

10	11	12	13	14	15	16
17	18	19	20	21	22	23

**CB4**

10	11	12	13	14	15	16
17	18	19	20	21	22	23

**D50**

10	11	12	13	14	15	16
10	11	12	13	14	15	16



**D51**

10	11	12	13	14	15	16
1	1	1	1	1	1	1

**D53**

	10	11	12	13	14	15	16
∅ 130	2	2	2	2	2	2	2
∅ 150	2	2	2	2	2	2	2
∅ 170	3	3	3	3	3	3	3

**D54**

10	11	12	13	14	15	16
4	4	4	4	4	4	4

**D58**

10	11	12	13	14	15	16
1	1	1	1	1	1	1

**D63**

10	11	12	13	14	15	16
4	4	4	4	4	4	4

**D64**

10	11	12	13	14	15	16
4	4	4	4	4	4	4

**D65**

10	11	12	13	14	15	16
4	4	4	4	4	4	4

**D66**

10	11	12	13	14	15	16
1	1	1	1	1	1	1

**D67**

10	11	12	13	14	15	16
2	2	2	2	2	2	2

**D68**

10	11	12	13	14	15	16
2	2	2	2	2	2	2

**D72**

10	11	12	13	14	15	16
3	3	4	4	4	5	5

**E05**

10	11	12	13	14	15	16
1	1	1	1	1	1	1

**F09**

	10	11	12	13	14	15	16
∅ 130	2	2	2	2	2	2	2
∅ 150	2	2	2	2	2	2	2
∅ 170	3	3	3	3	3	3	3

**F33**

	10	11	12	13	14	15	16
∅ 130	4	4	4	4	4	4	4
∅ 150	4	4	4	4	4	4	4
∅ 170	6	6	6	6	6	6	6

**F34**

10	11	12	13	14	15	16
7	7	7	7	7	7	7

**F44**

10	11	12	13	14	15	16
2	2	2	2	2	2	2

**F45**

10	11	12	13	14	15	16
2	2	2	2	2	2	2

**F50**

10	11	12	13	14	15	16
17	18	19	20	21	22	23

**F51**

10	11	12	13	14	15	16
34	36	38	40	42	44	46

**F52**

10	11	12	13	14	15	16
17	18	19	20	21	22	23

**F55**

10	11	12	13	14	15	16
17	18	19	20	21	22	23

**G02**

10	11	12	13	14	15	16
2	2	2	2	2	3	3

**G03**

10	11	12	13	14	15	16
1	1	1	1	1	1	1

**G09**

10	11	12	13	14	15	16
1	1	1	1	1	1	1

**H05**

10	11	12	13	14	15	16
1	1	1	1	1	1	1

**H06**

10	11	12	13	14	15	16
1	1	1	1	1	1	1

**H12**

10	11	12	13	14	15	16
27	29	31	33	35	37	39

**L32**

10	11	12	13	14	15	16
9	10	11	12	13	14	15

**X01**



**IT) ATTENZIONE!**

**Leggere e seguire scrupolosamente queste istruzioni e tenere per future consultazioni.**

Eseguire l'installazione "a regola d'arte", utilizzando attrezzi idonei; seguire scrupolosamente le istruzioni di montaggio. Informarsi prima dell'installazione, sui regolamenti locali e nazionali da rispettare, in funzione della destinazione d'uso (privato principale, secondario, uffici, negozi,...).

**EN) WARNING!**

**Carefully read and strictly follow these instruction and keep them for future consultation.**

Carry out the installation in a "workmanlike" manner, strictly following the installation instructions and using suitable tools. Always consult your local building department for code requirements that must be respected depending on its destination of use (private, secondary, public...).

**DE) ACHTUNG!**

**Lesen sie diese Anleitung sorgfältig durch und heben sie sie für spätere Zwecke auf.**

Die Montage muss fachgerecht, unter Zuhilfenahme geeigneter Hilfsmittel und unter strikter Einhaltung der Montageanleitung ausgeführt werden. Damit die Montage normgerecht erfolgen kann, muss man zuvor Informationen zur Aufstellung und zu den lokal und national geltenden Vorschriften je nach Bestimmungszweck (privat, Haupt- oder Nebeneinrichtung, Büros, Geschäfte, ...) einholen.

**FR) ATTENTION !**

**Lire et respecter scrupuleusement les présentes instructions ; les conserver pour toute autre consultation.**

Effectuer l'installation dans les règles de l'art en utilisant des outils appropriés ; suivre scrupuleusement les instructions de montage. Pour réaliser un montage conforme aux normes en vigueur, il faut s'informer avant l'installation quant aux réglementations locales et nationales à respecter, en fonction du domaine d'utilisation (résidence privée principale, secondaire, bureaux, magasins,...).

**ES) ¡ATENCIÓN!**

**Leer y seguir estrictamente estas instrucciones y conservarlas para consultas futuras.**

Realizar la instalación "según las reglas del arte", utilizando herramientas adecuadas; seguir estrictamente las instrucciones de montaje. Informarse antes de la instalación sobre los reglamentos locales y nacionales a respetar, en función del destino de uso (privado principal, secundario, oficinas, tiendas,...).

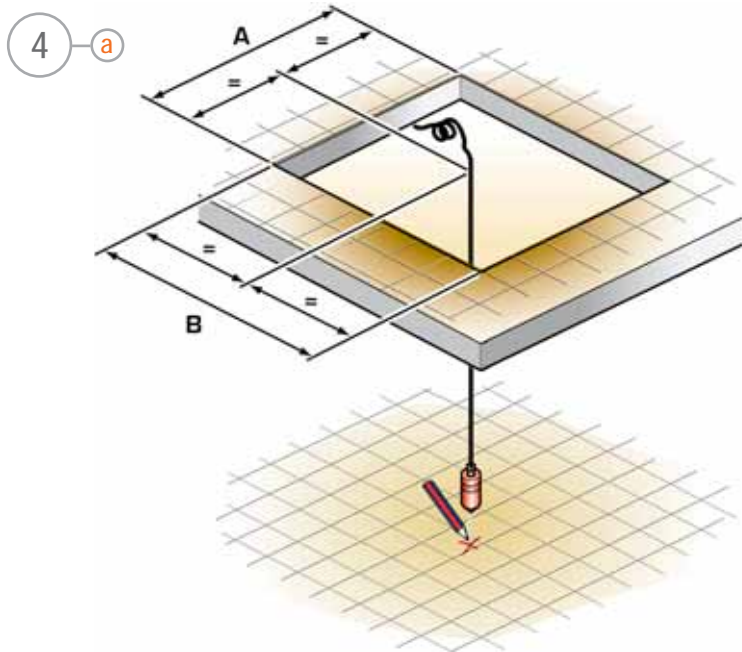

4 b

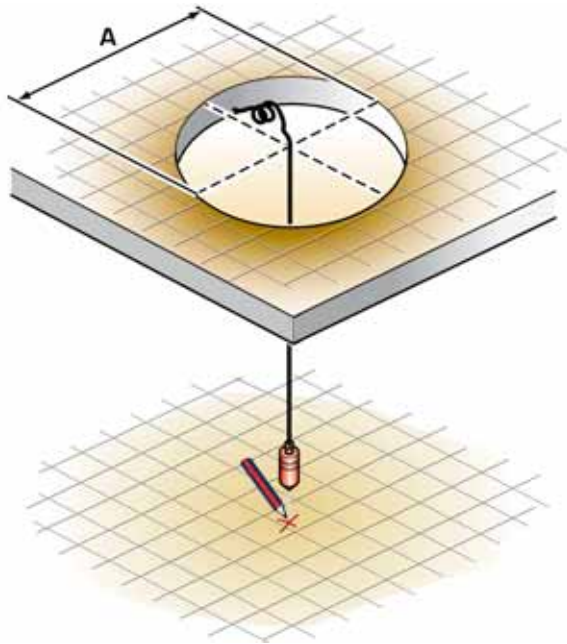

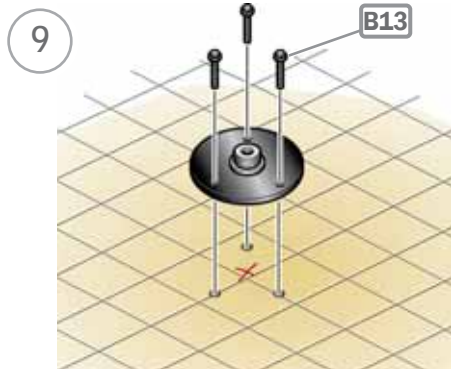
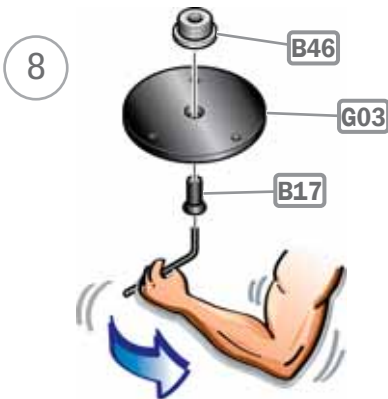
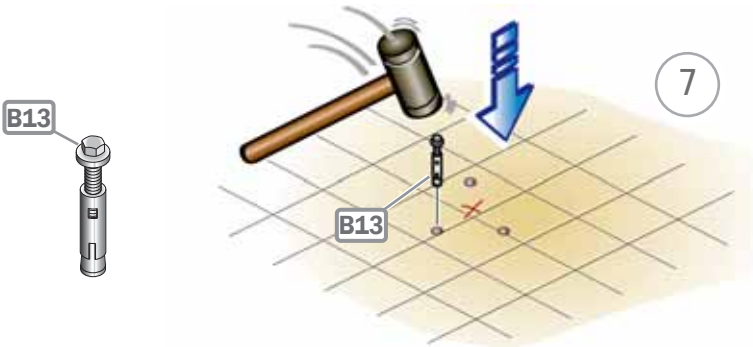
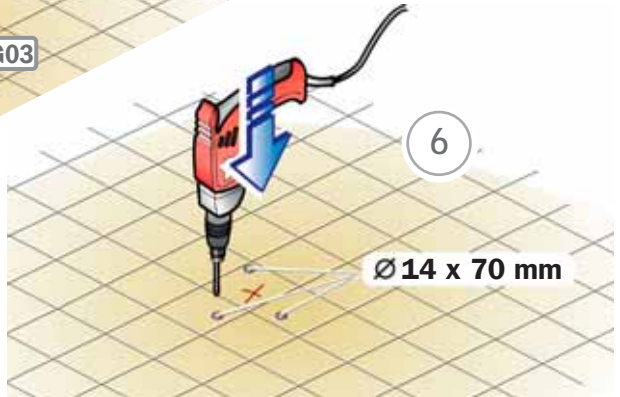
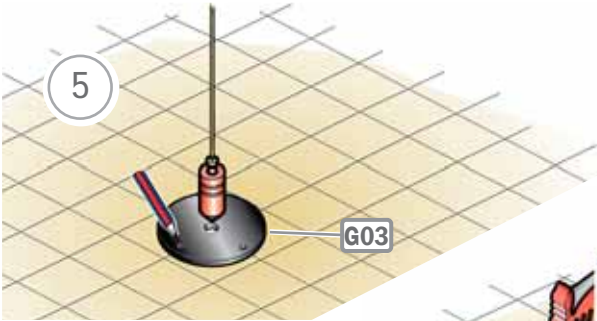

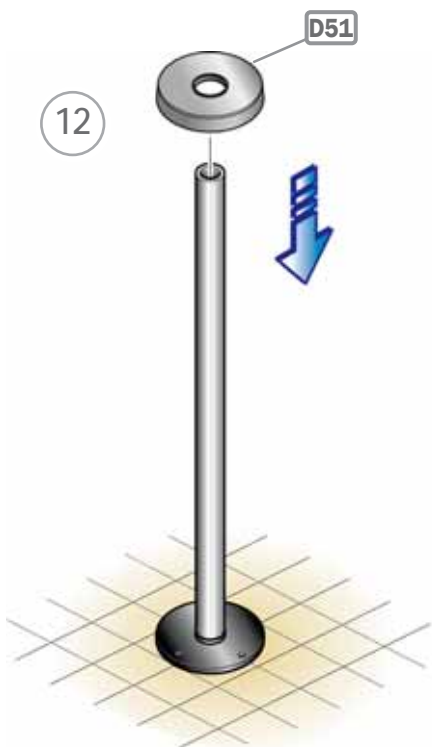
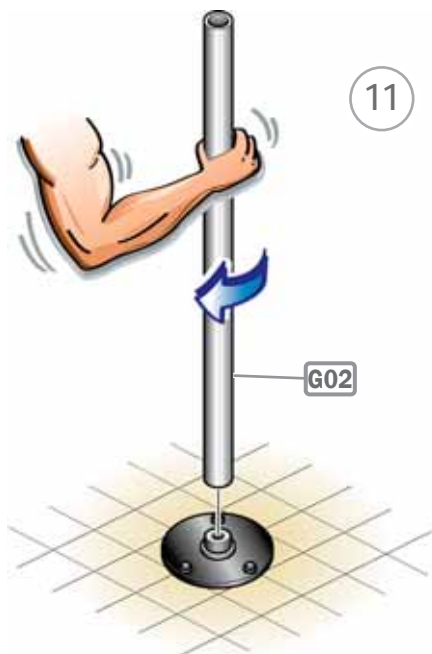

10 (N)



11 (N)



12 (N)



13 (N)



$$R = H / N$$

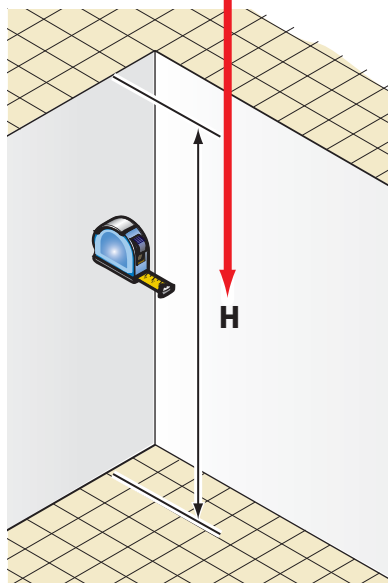
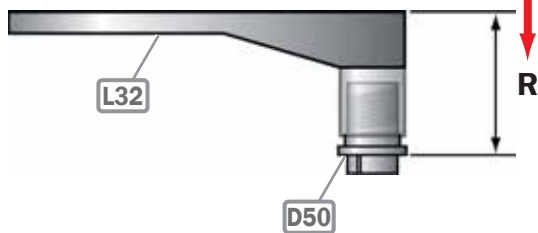



**14 (N)**



**15 (N)**



**16 (N)**

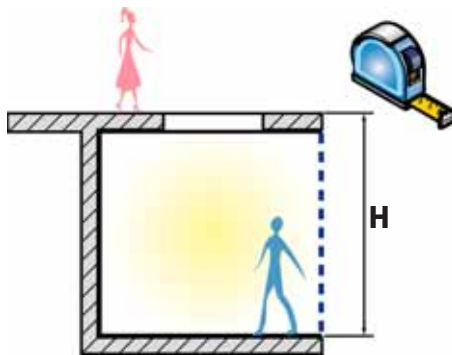

**10 (N) → H = 199 ÷ 232 cm**

**11 (N) → H = 219 ÷ 255 cm**

**12 (N) → H = 239 ÷ 278 cm**

**13 (N) → H = 258 ÷ 302 cm**

**14 (N) → H = 278 ÷ 325 cm**

**15 (N) → H = 298 ÷ 348 cm**

**16 (N) → H = 318 ÷ 371 cm**

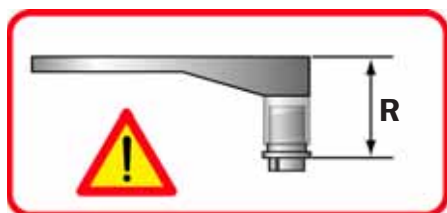
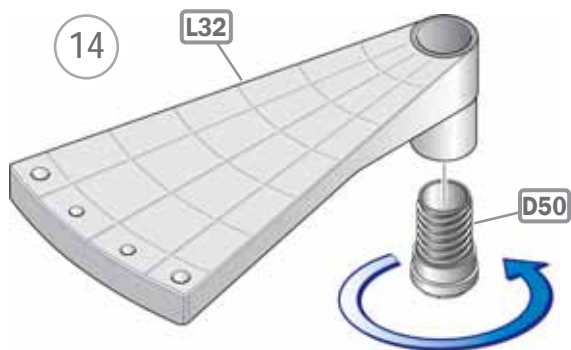
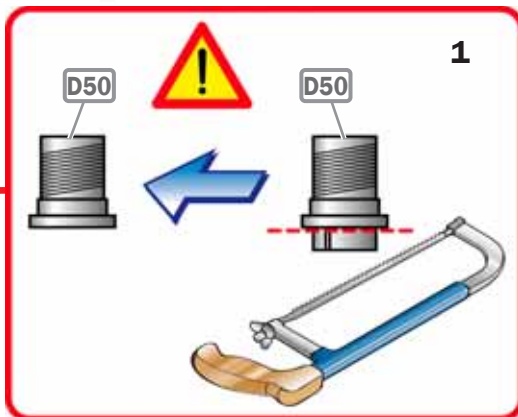
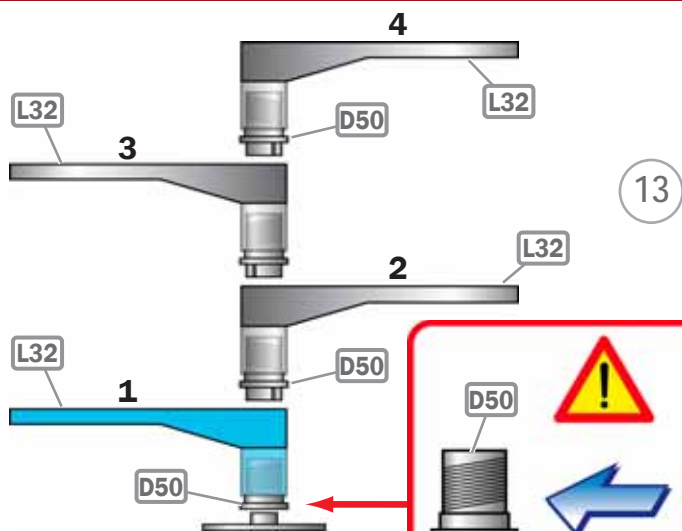

R =   
16 - 17

15

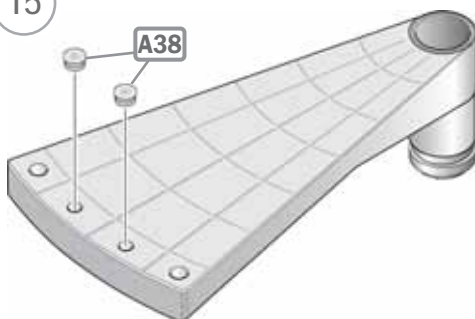

16

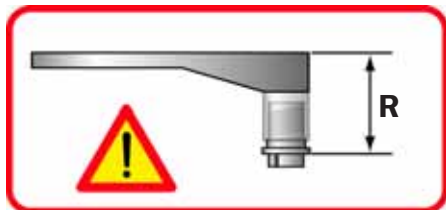
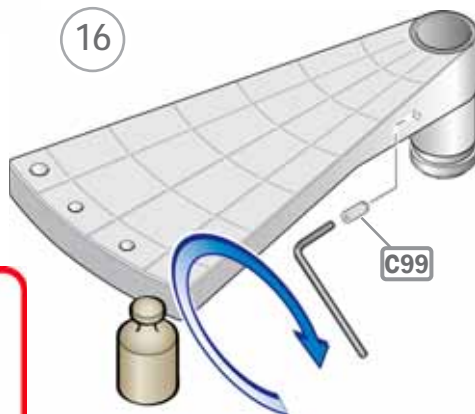

17

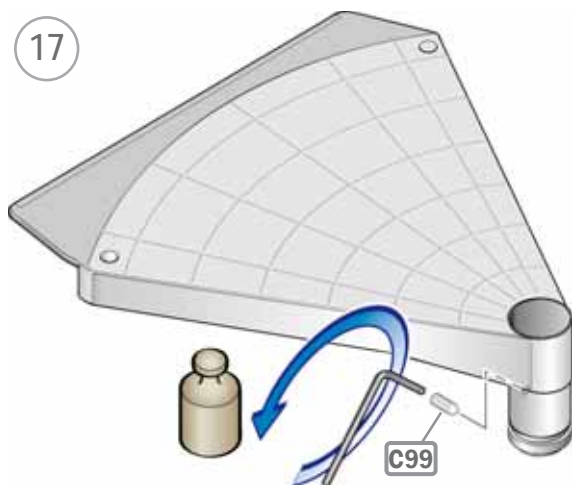

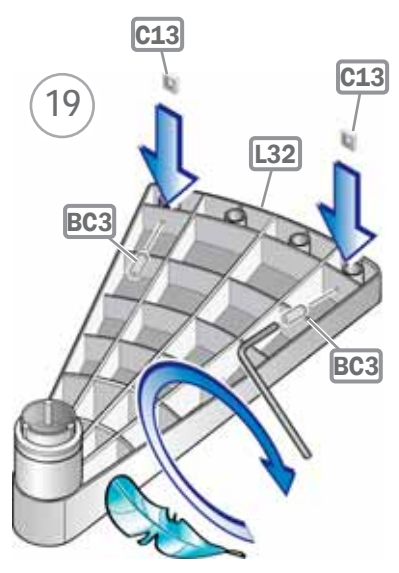
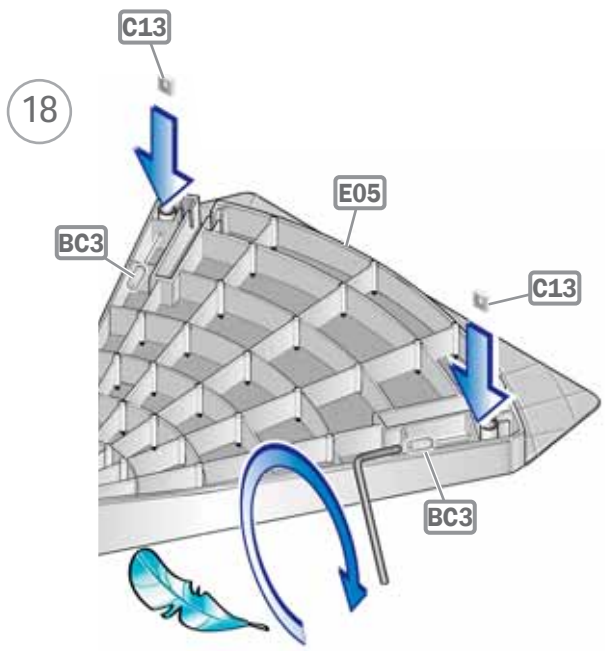

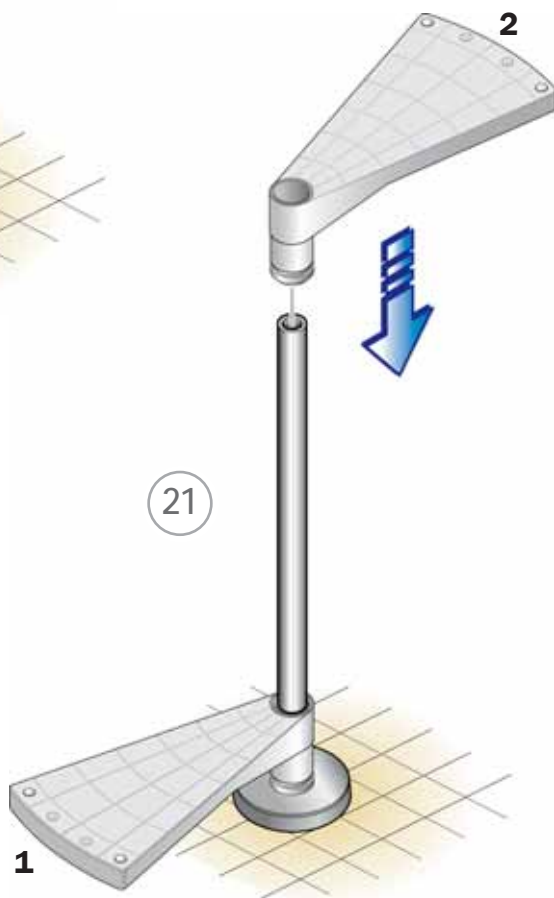
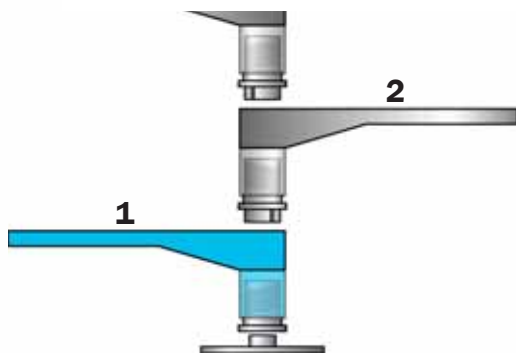
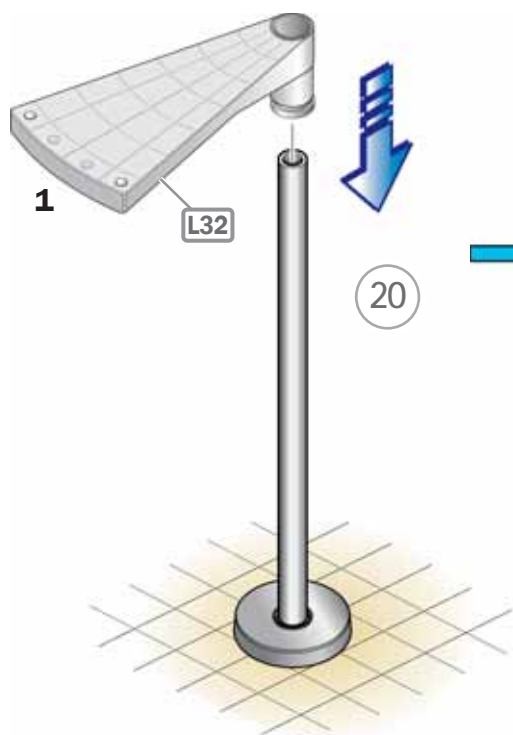

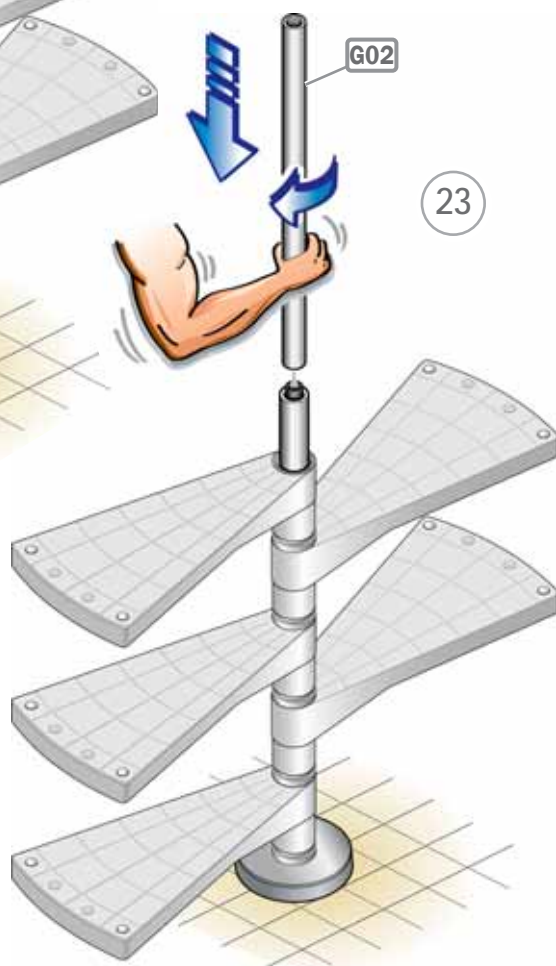
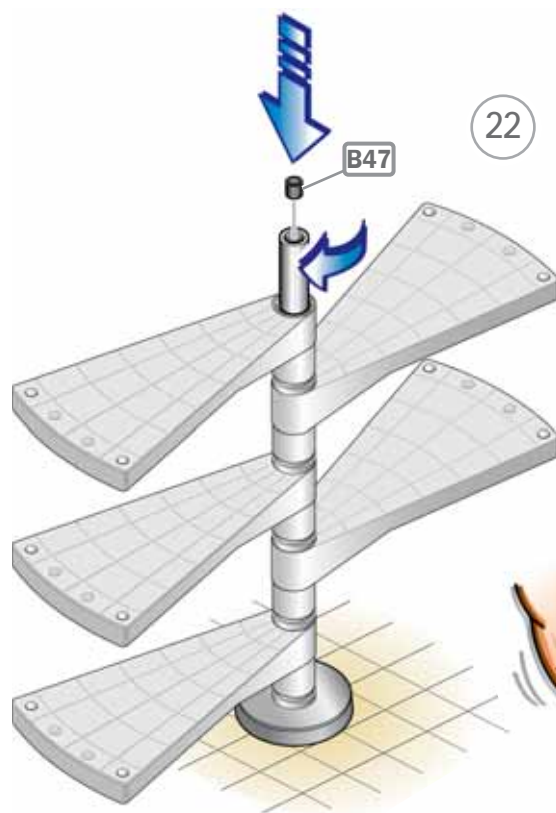

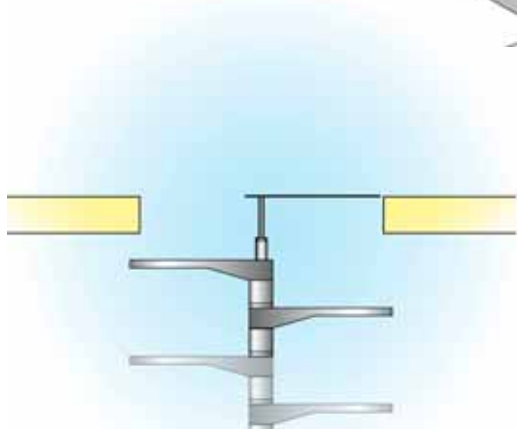
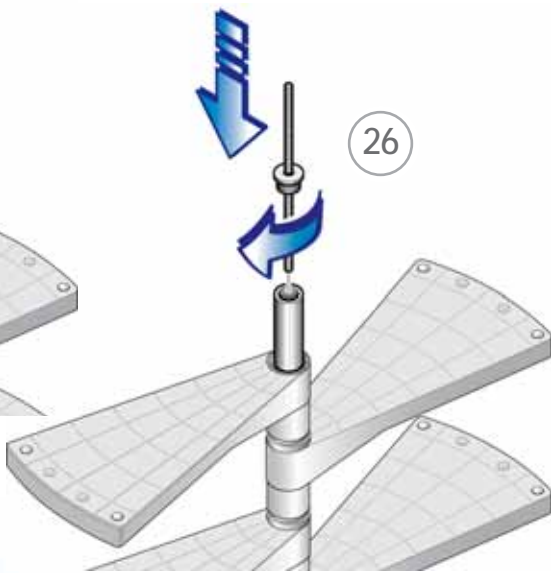
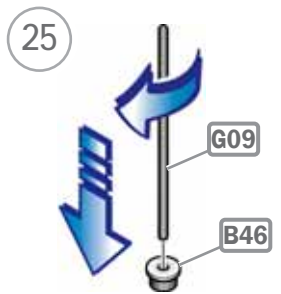
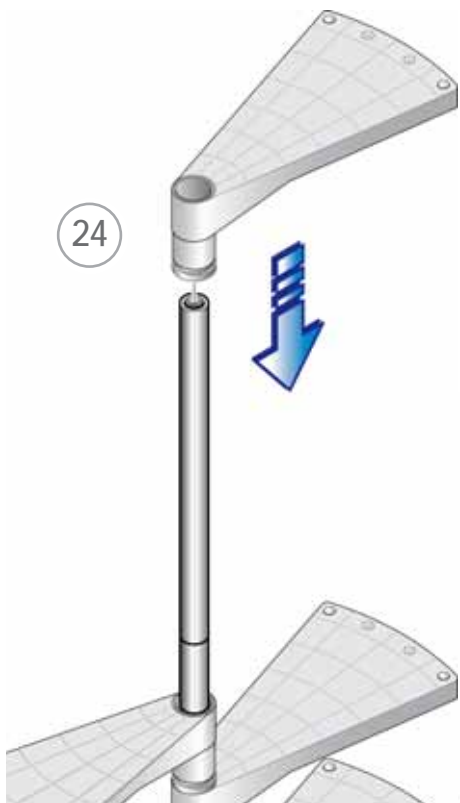

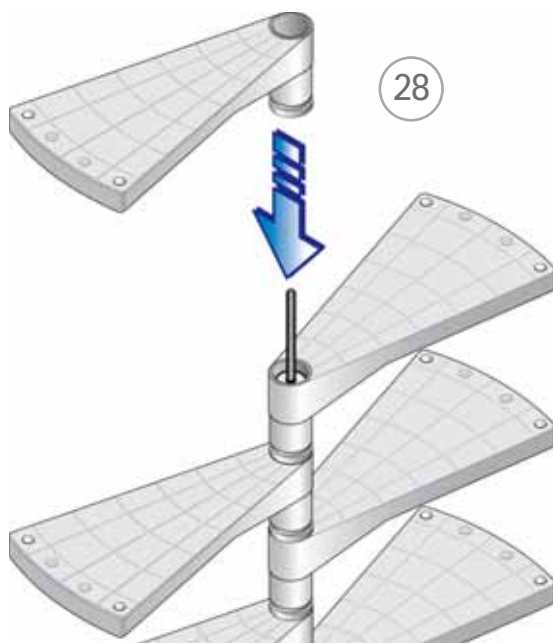
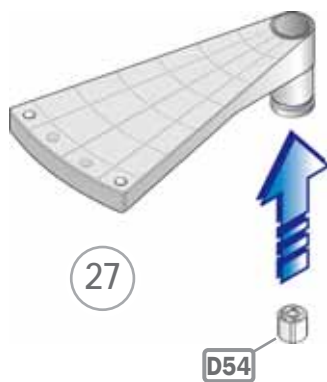

29

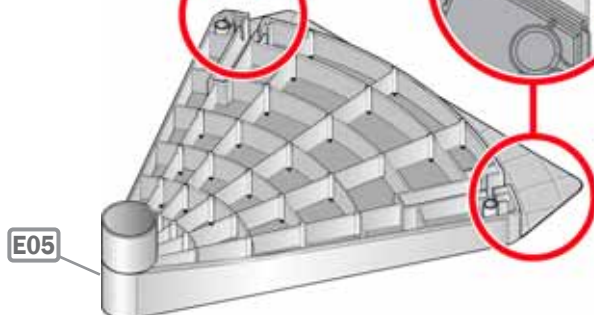



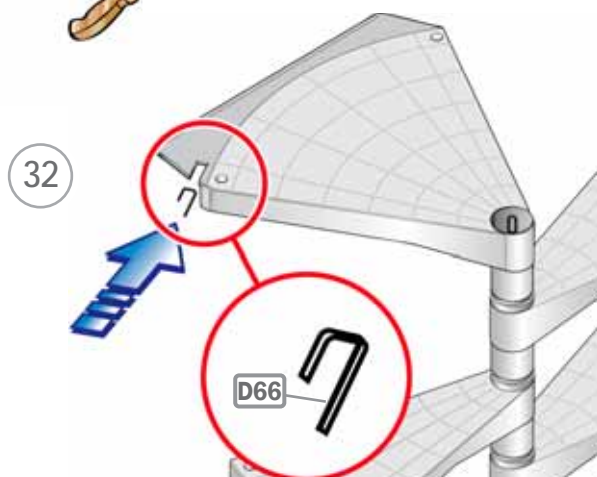
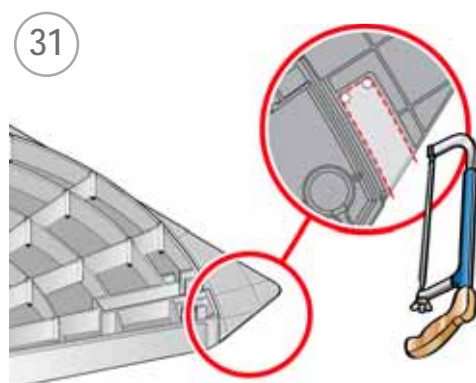
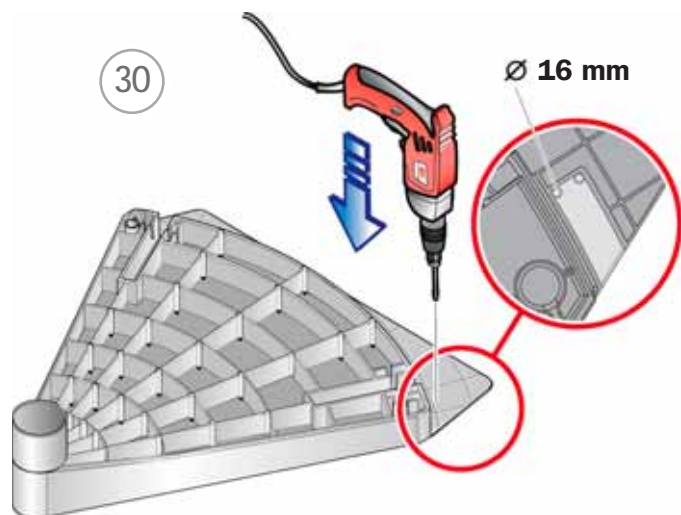

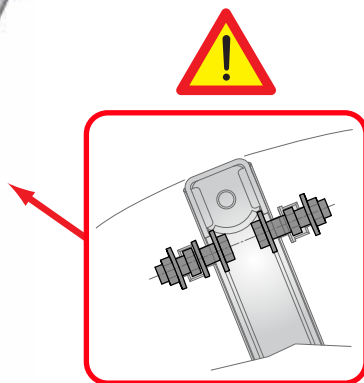
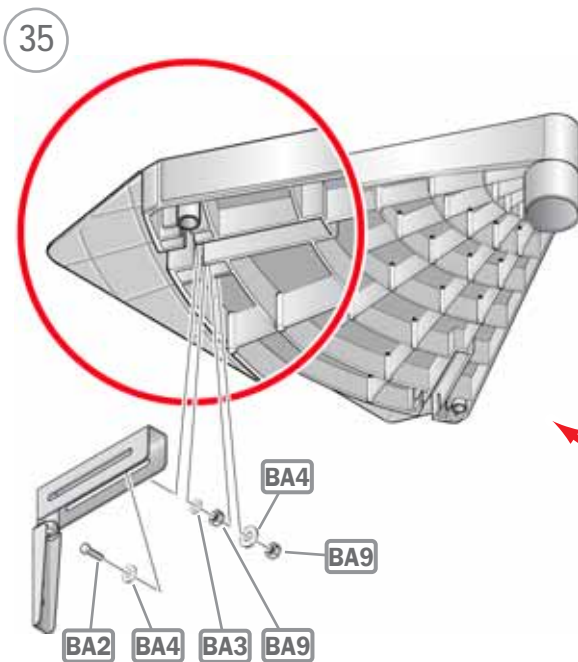
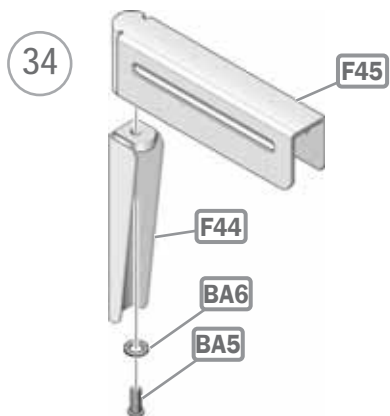
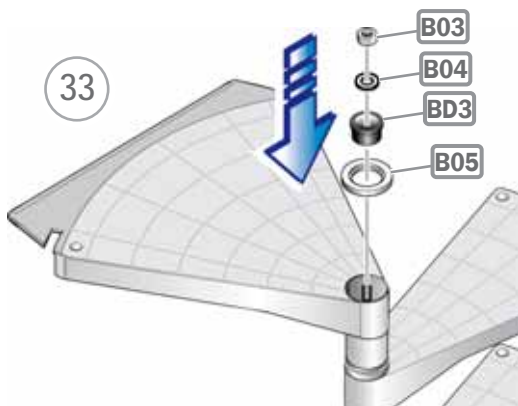

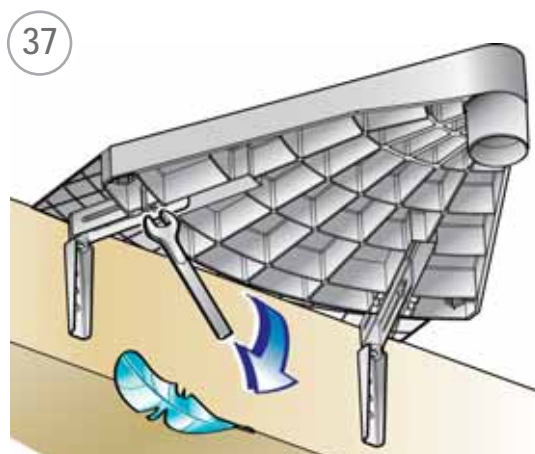
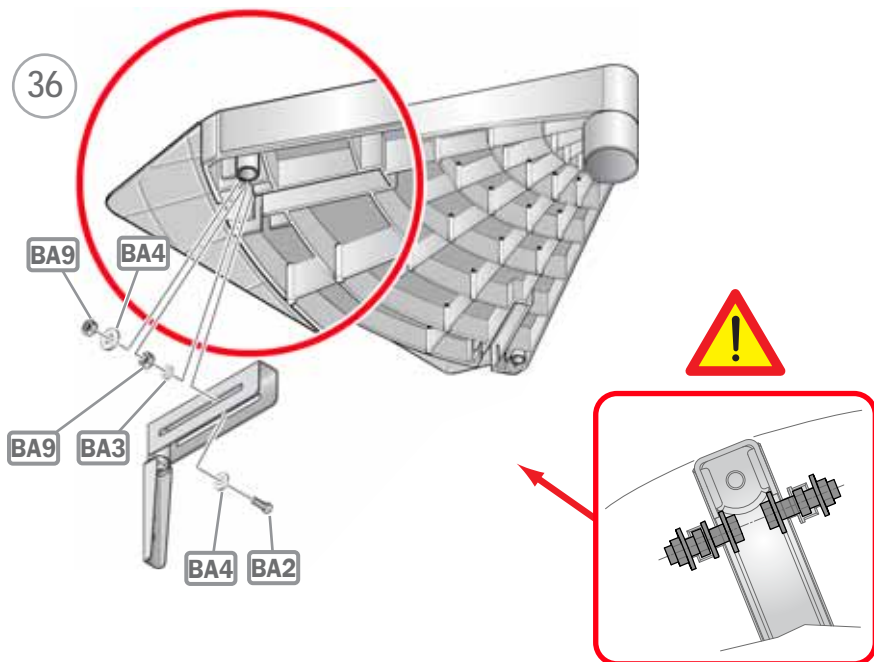

38

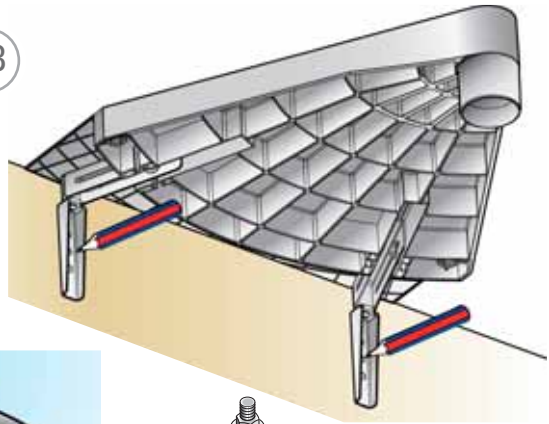

39

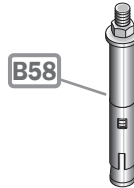
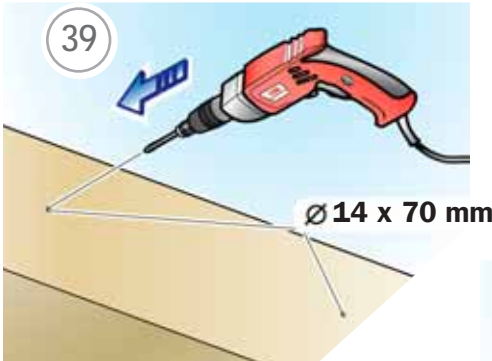

40

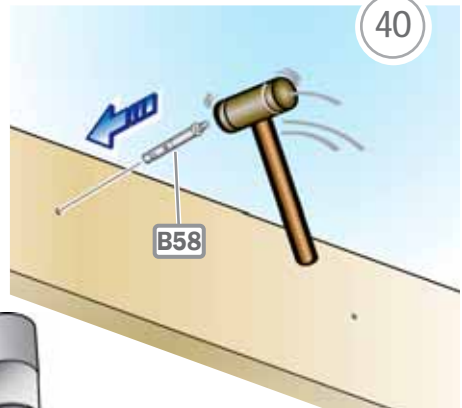

41

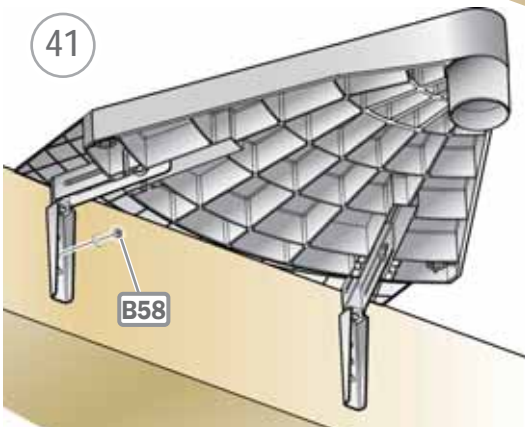

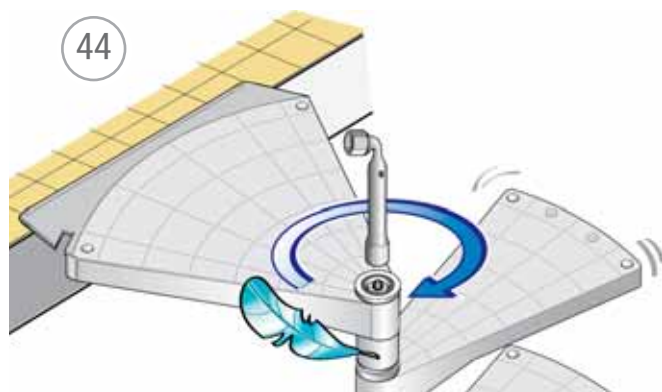
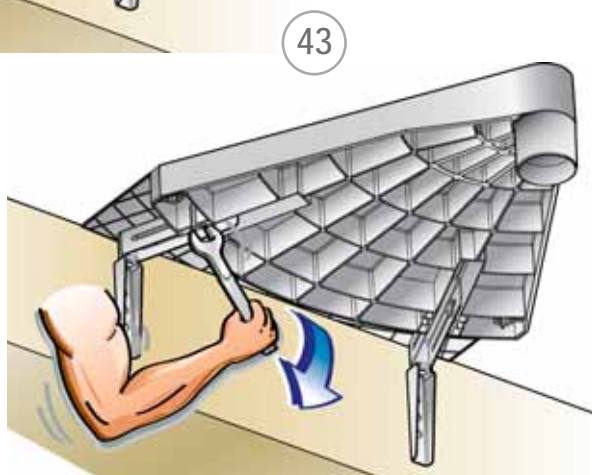

45

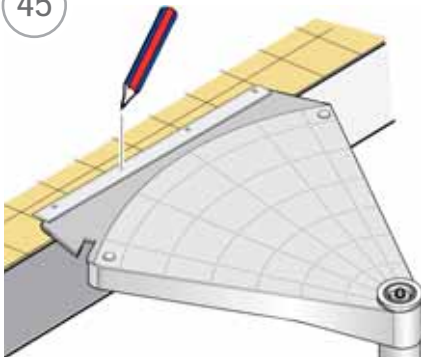

46

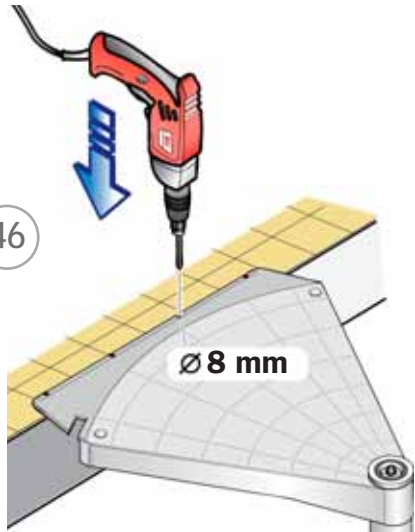

47

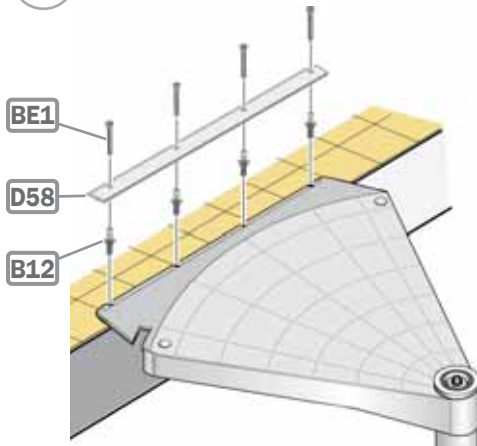

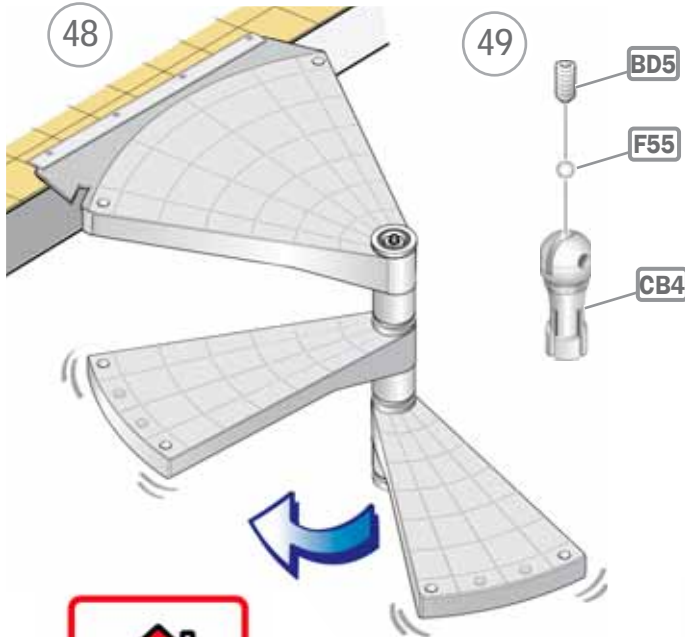

51-a



51-b

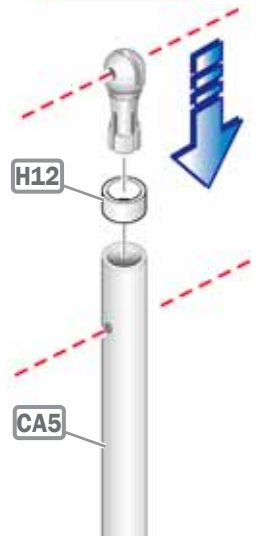
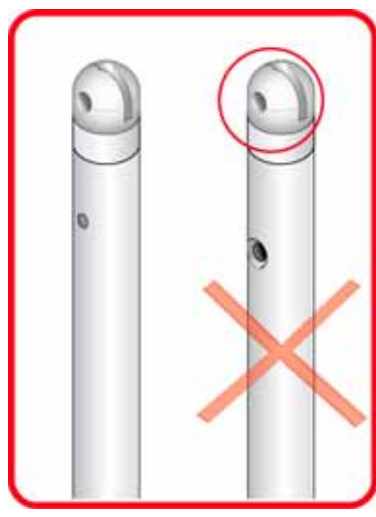
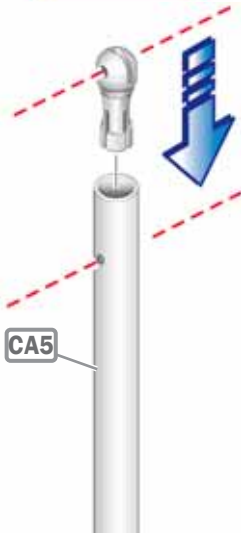

52

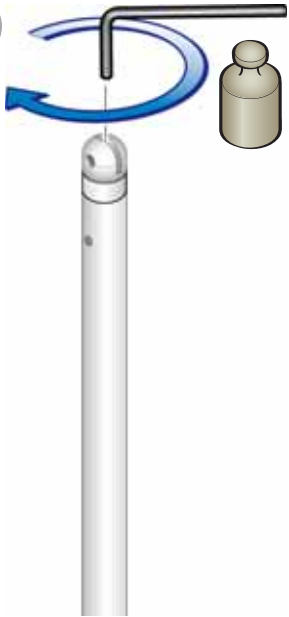

53 a



53 b



54



55 a

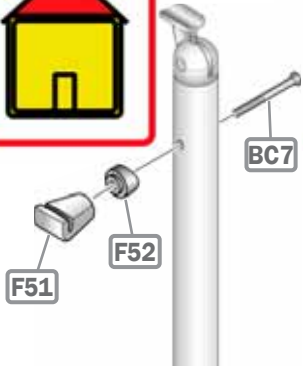

55 b

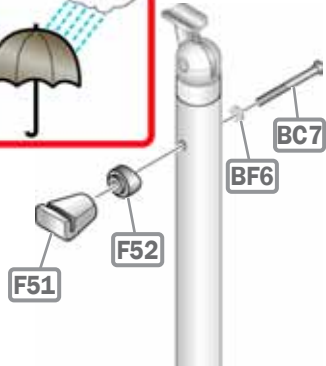



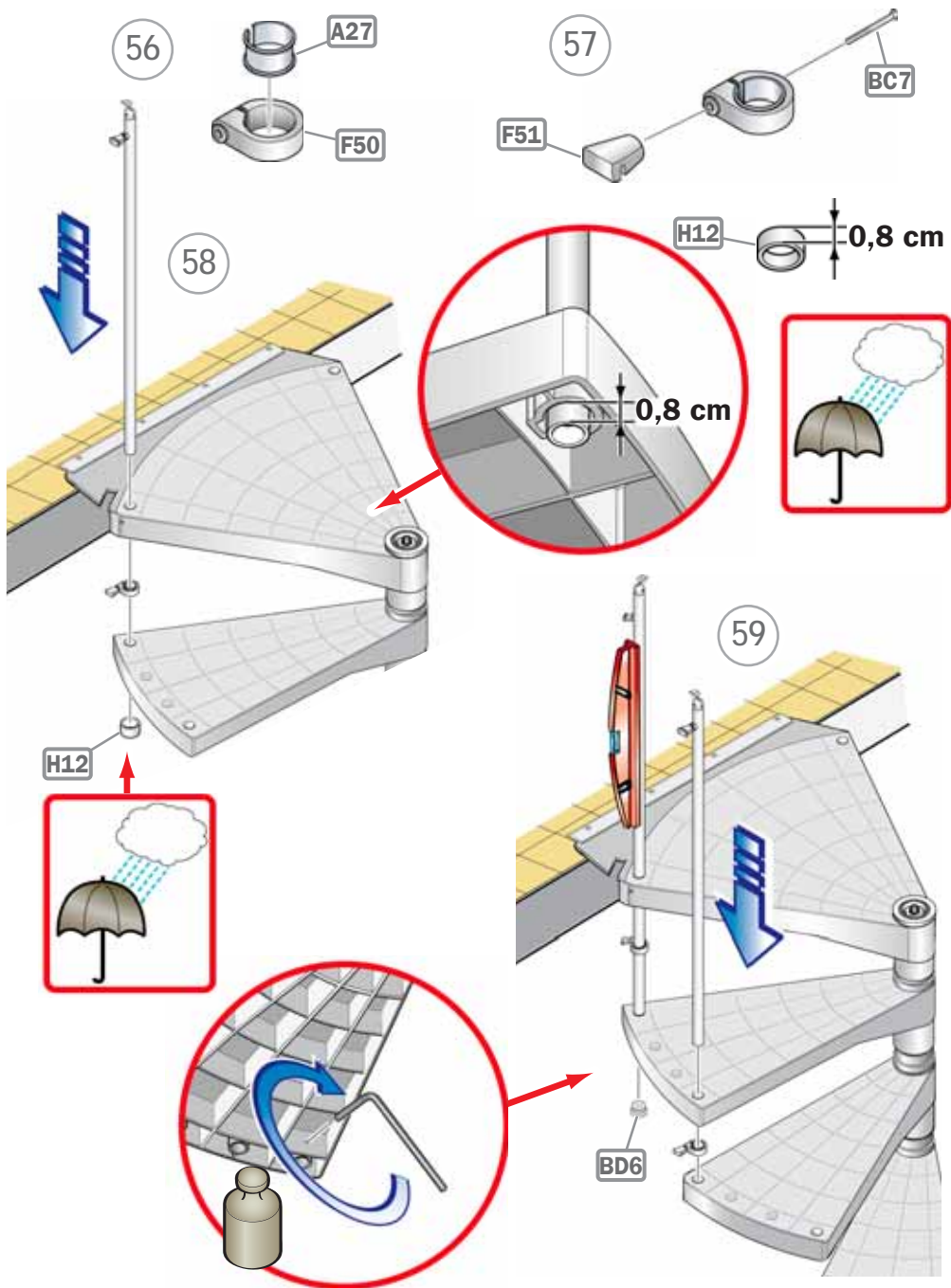

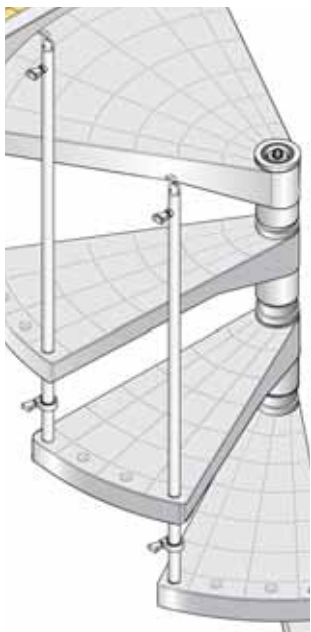

60

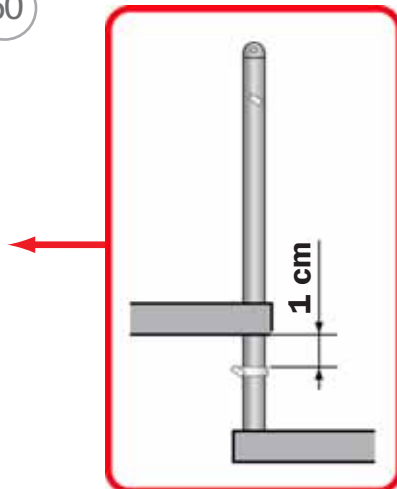

61

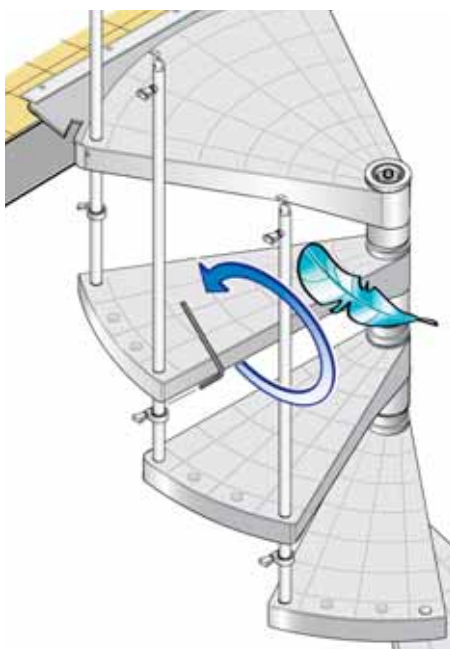

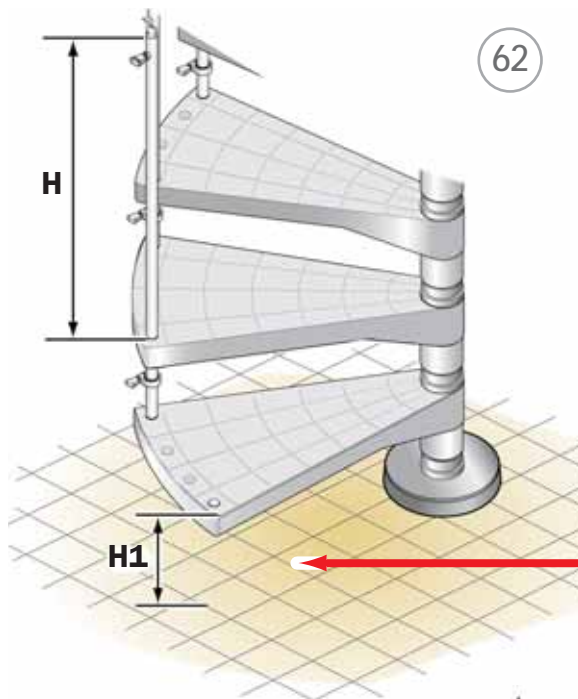

62

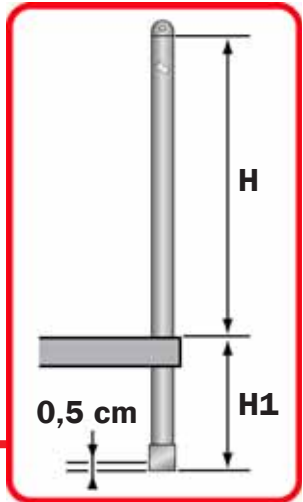

63



$$L = H + H1 - 0,5 \text{ cm}$$

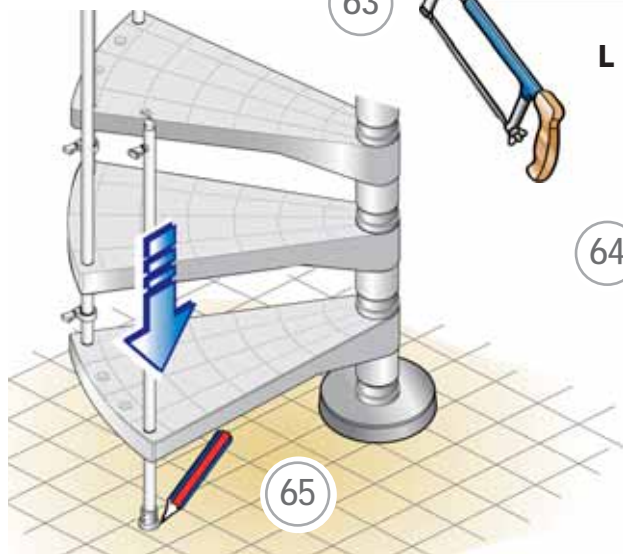

65

64



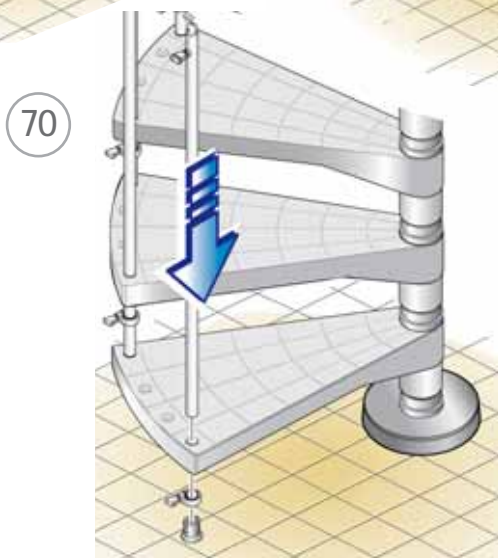
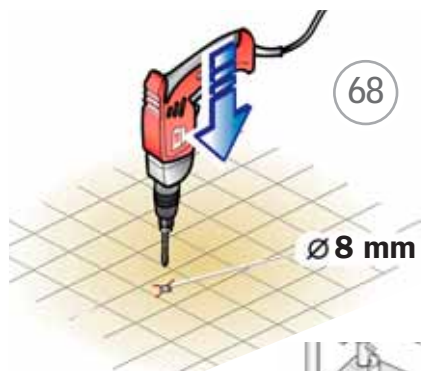
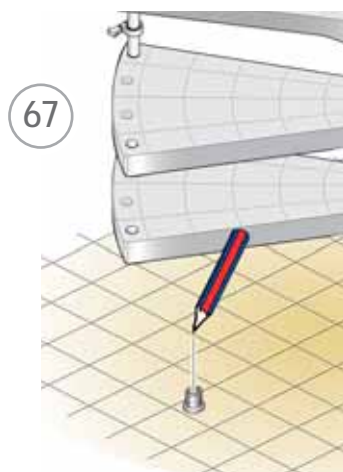
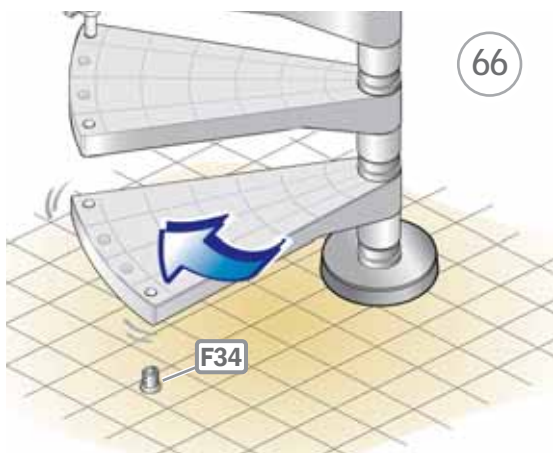

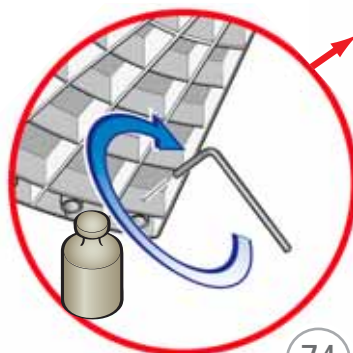
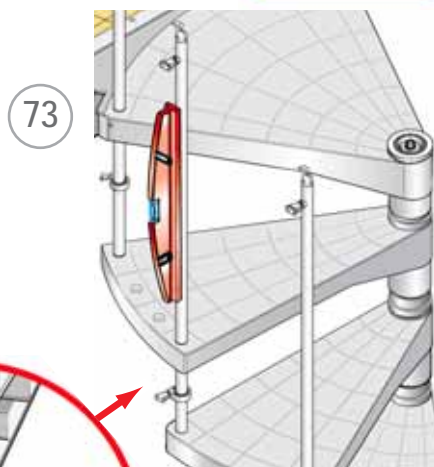
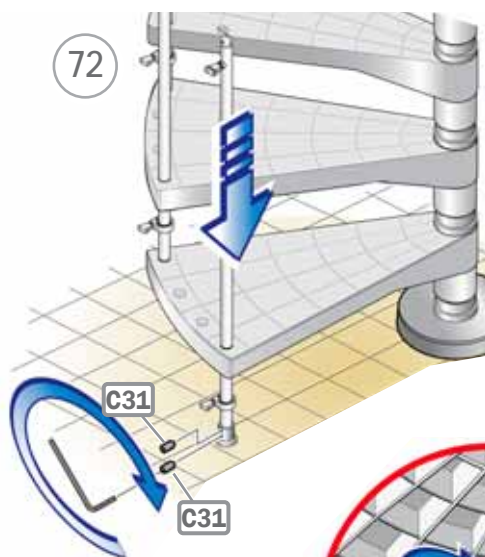
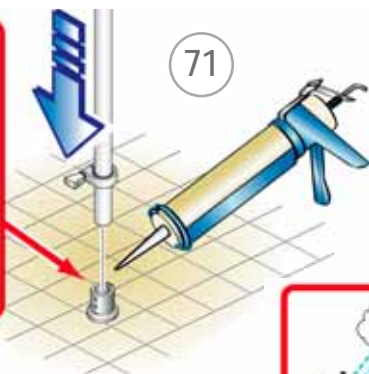
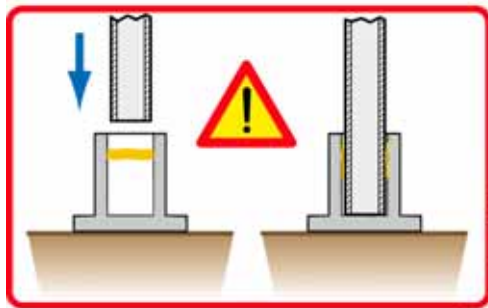

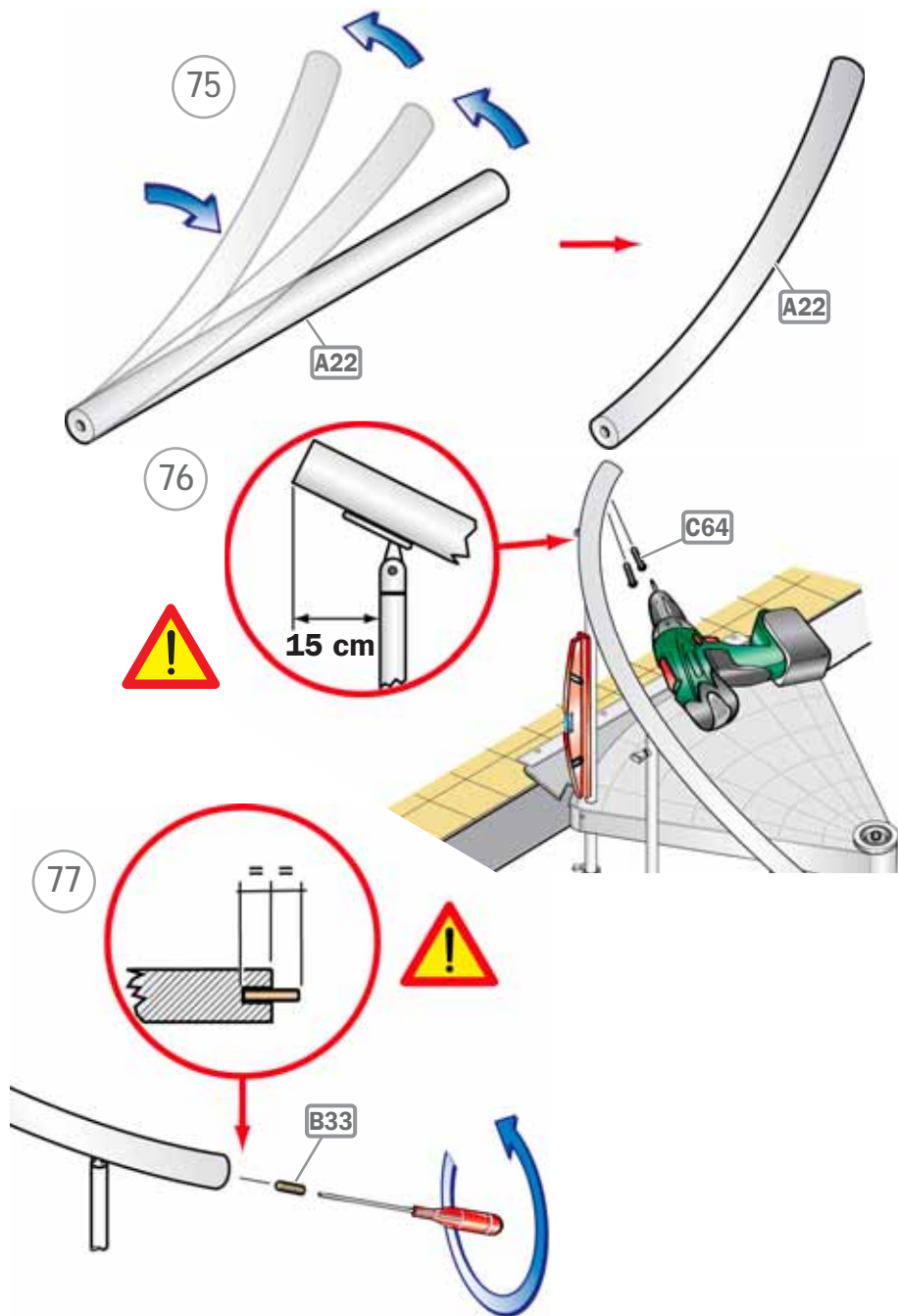

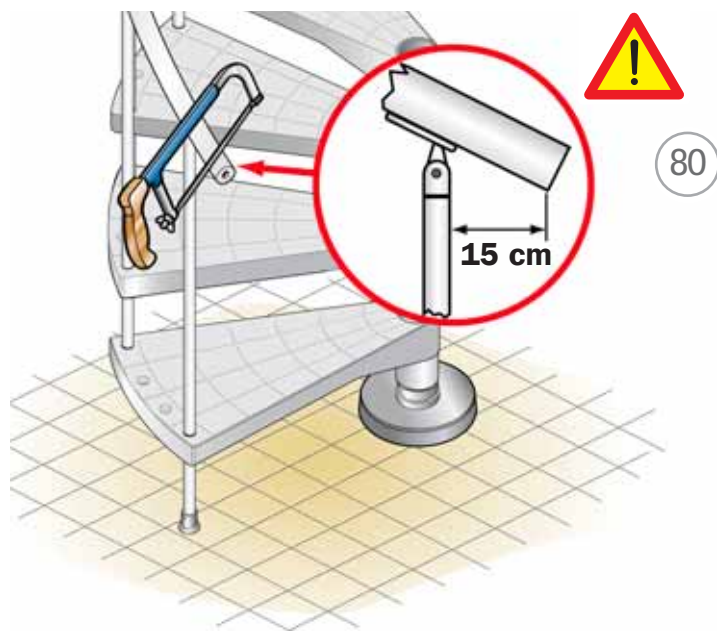
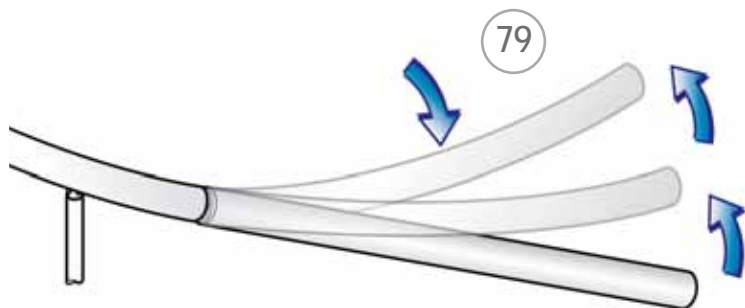
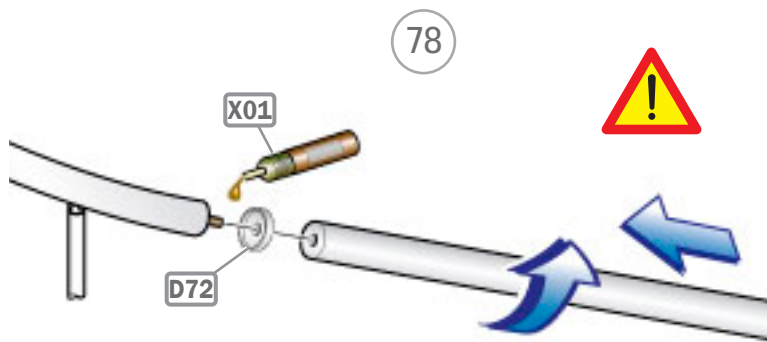

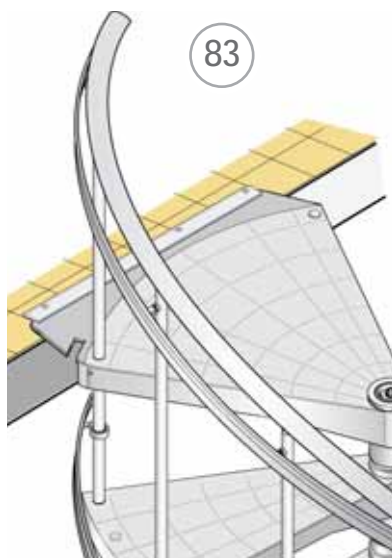
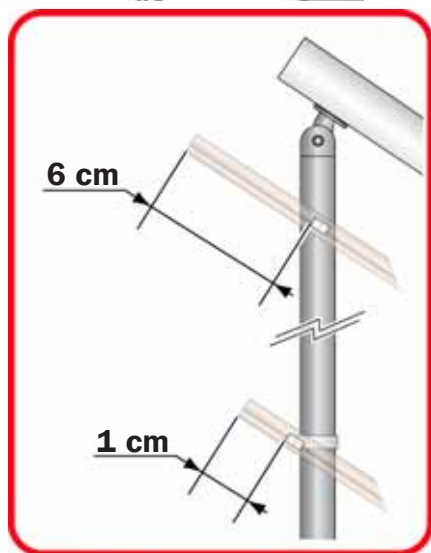
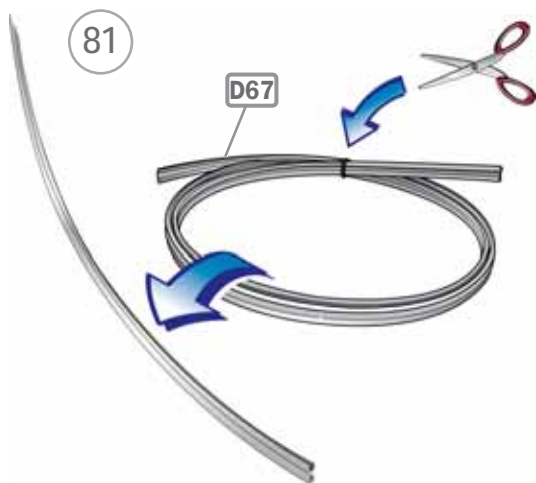
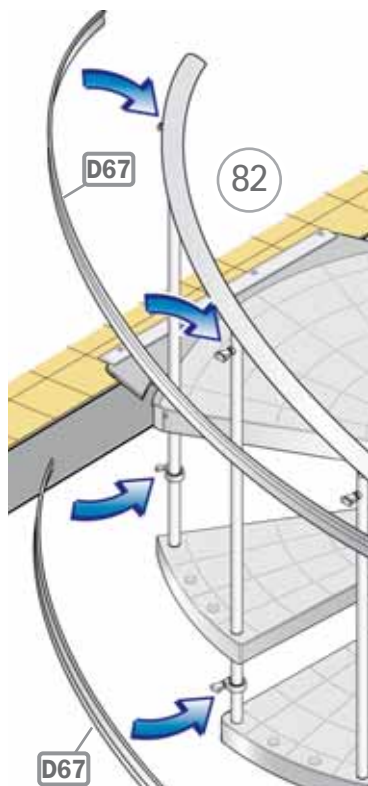



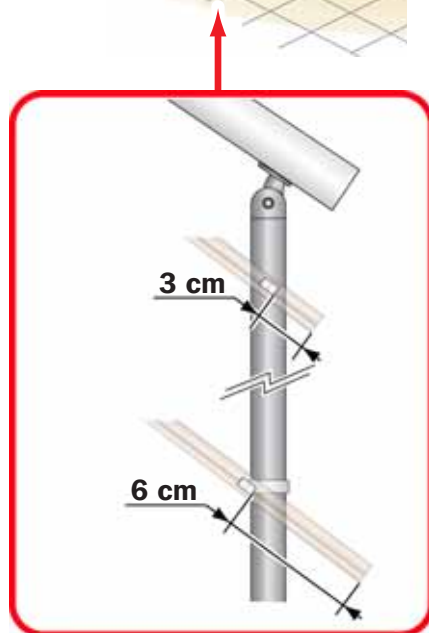
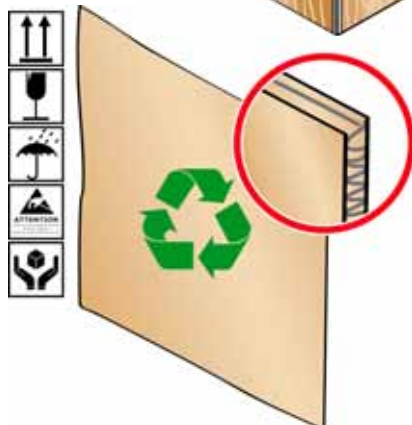
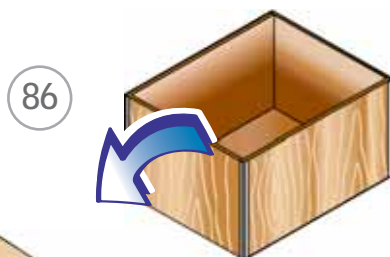
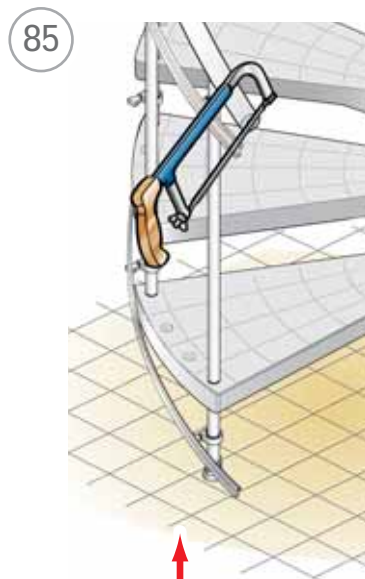
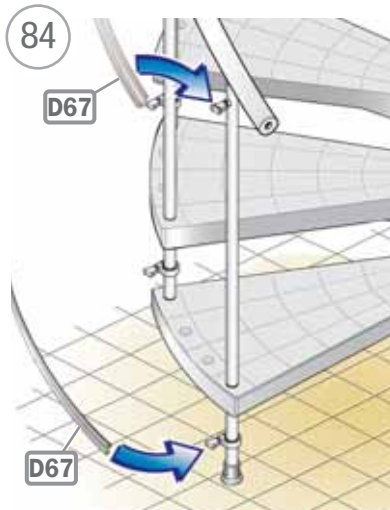

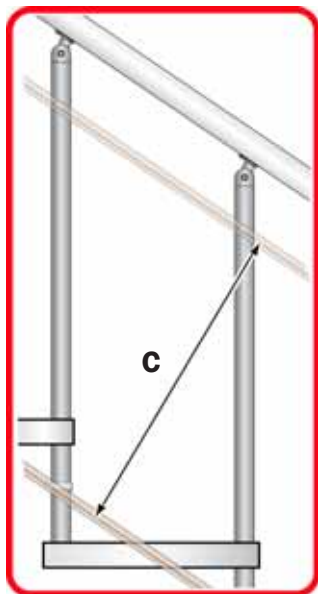

87

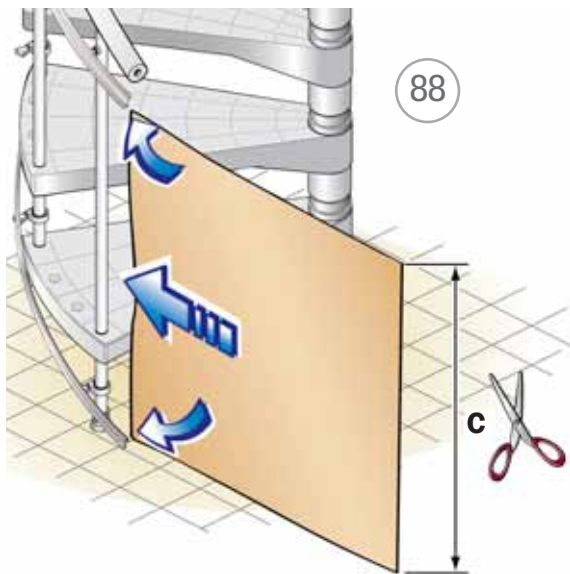
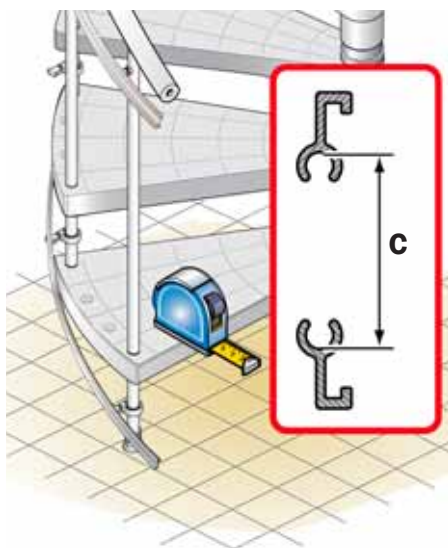

88

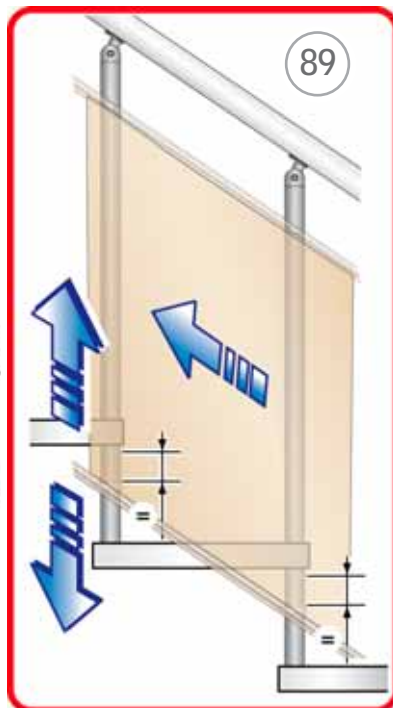

89

91

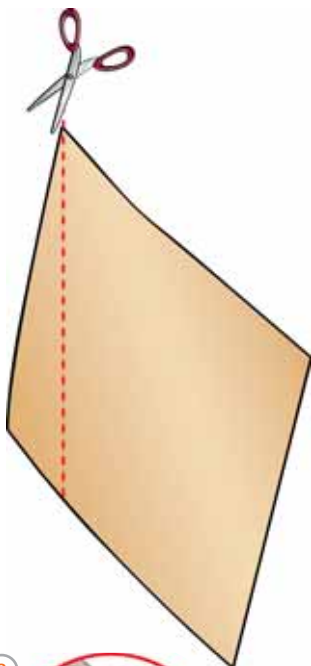

90

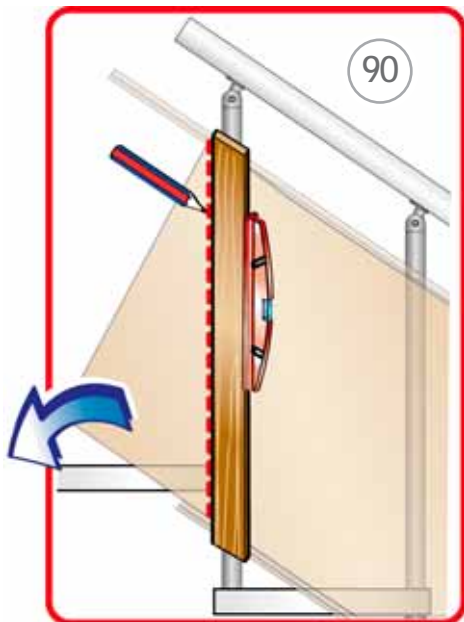

92 a

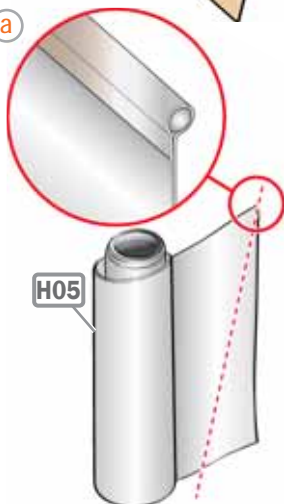

92 b

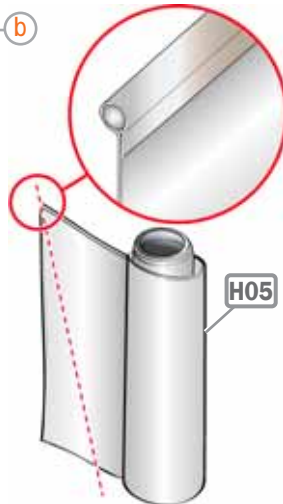

93

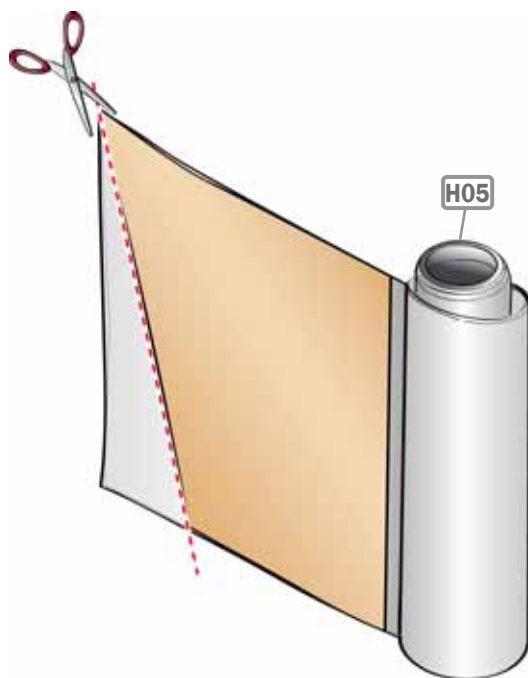

94

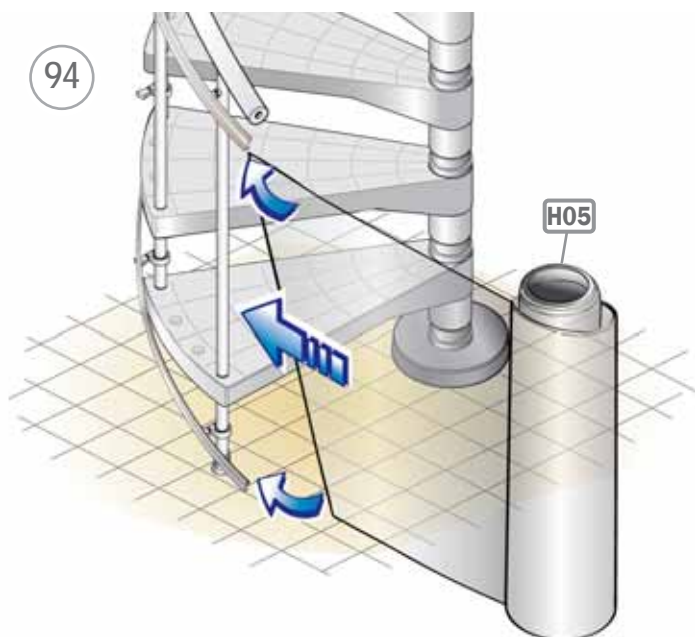

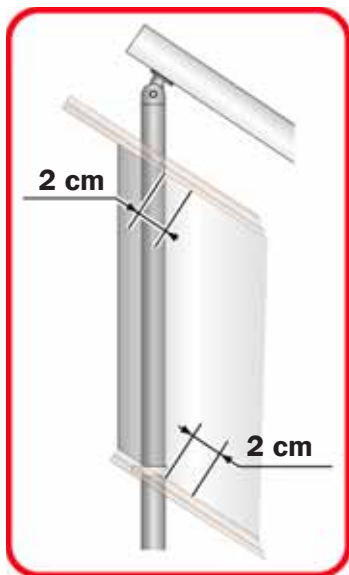

95

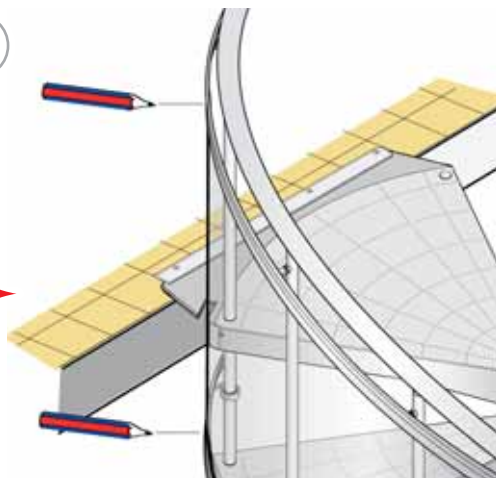

96

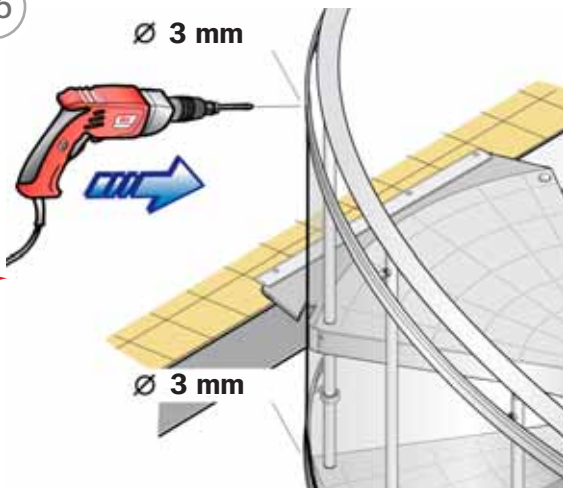
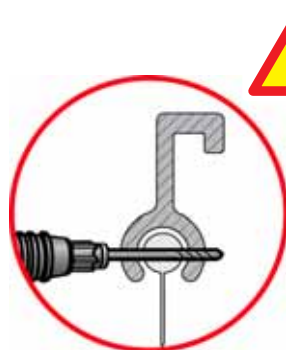

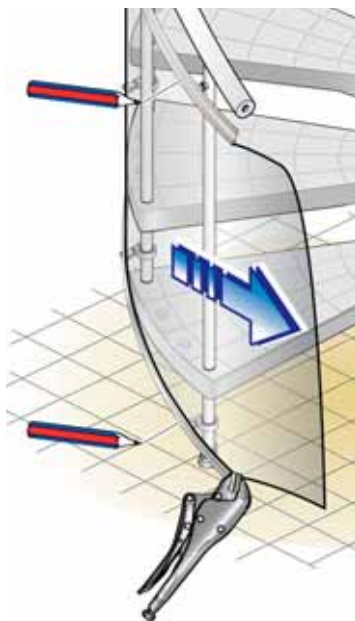
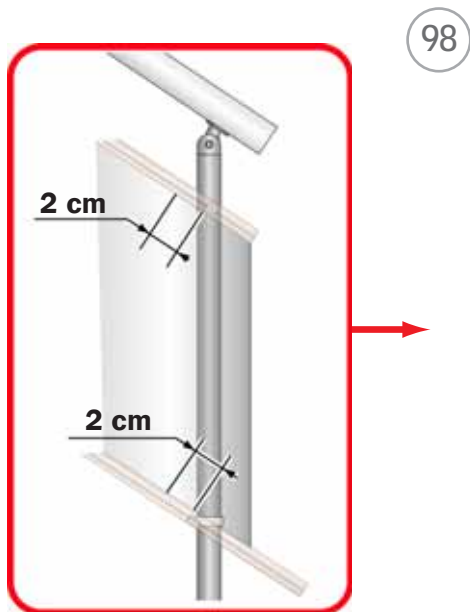
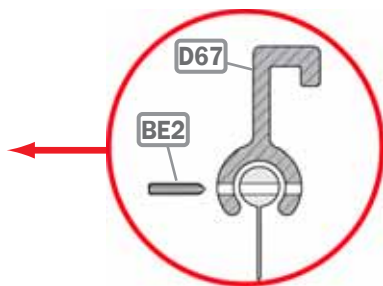
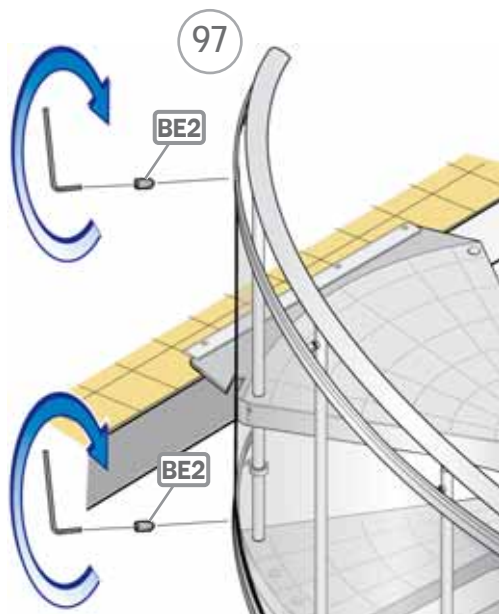

99



Ø 3 mm

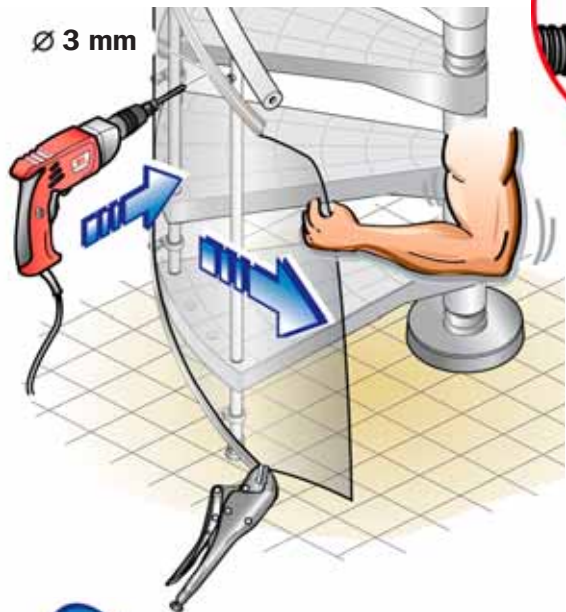

100



BE2

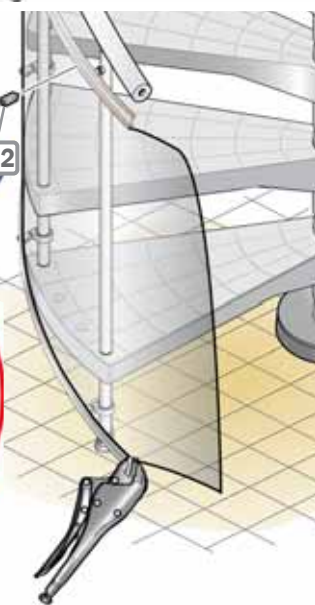

101

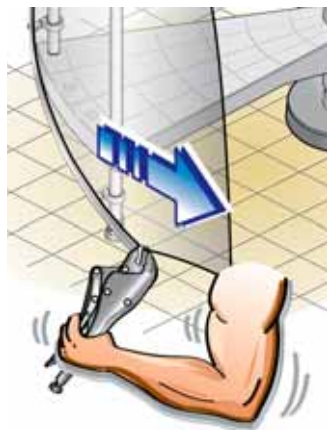

102

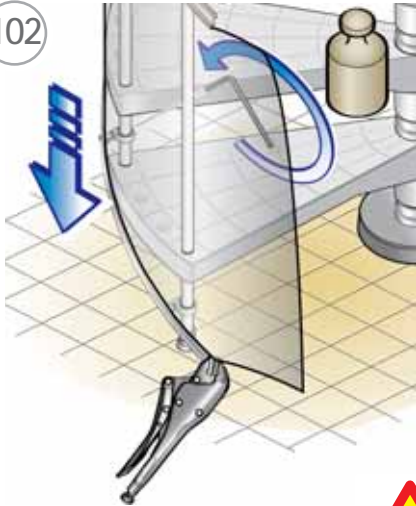

103

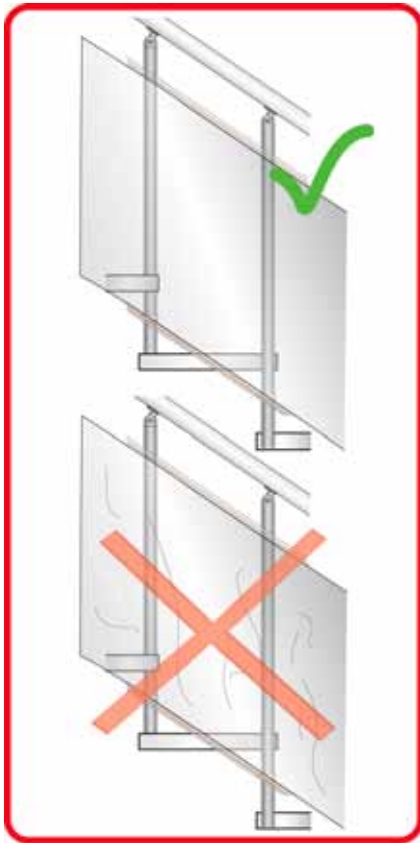
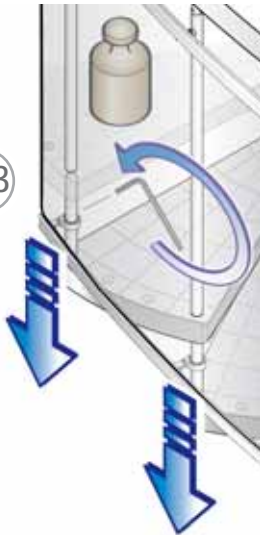

104

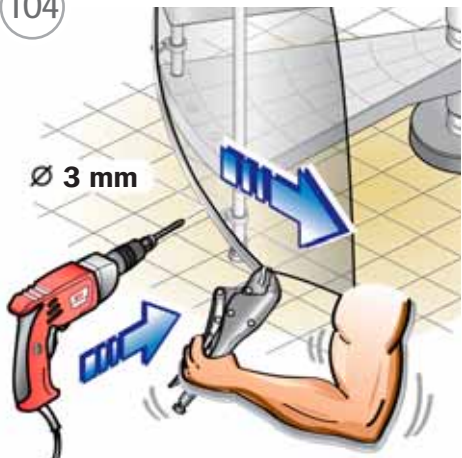



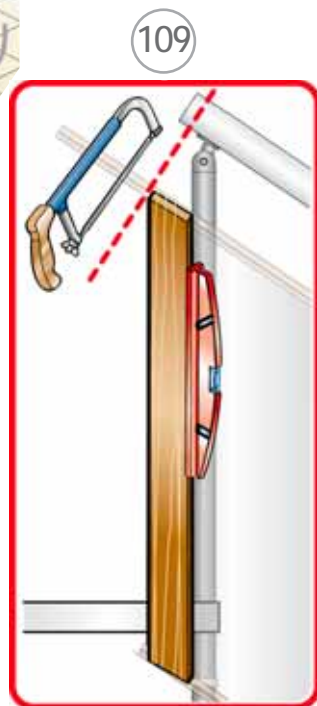
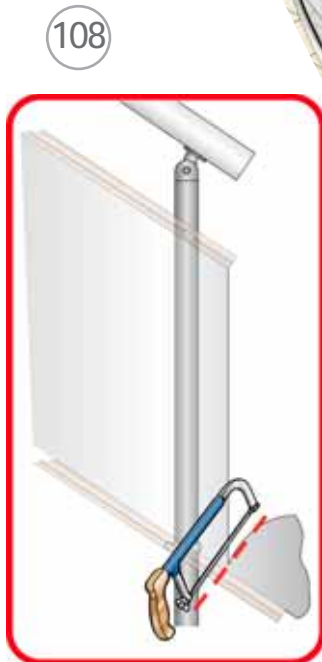
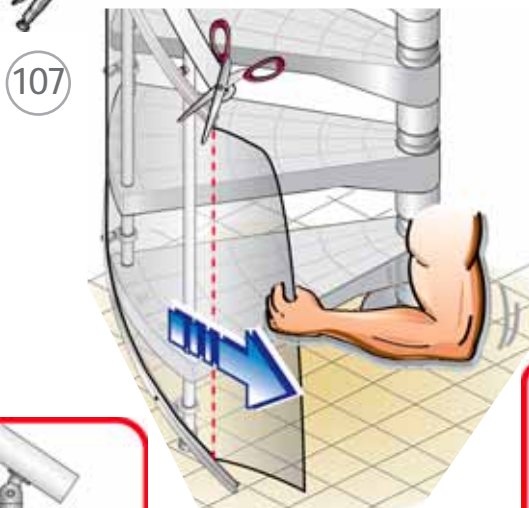
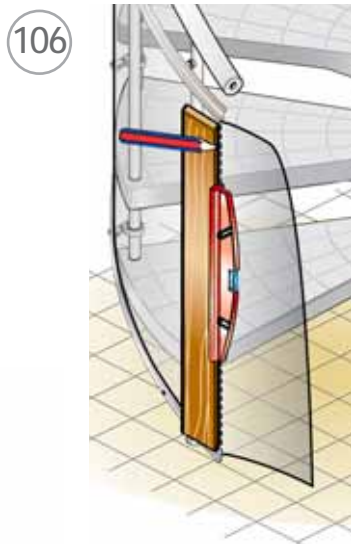
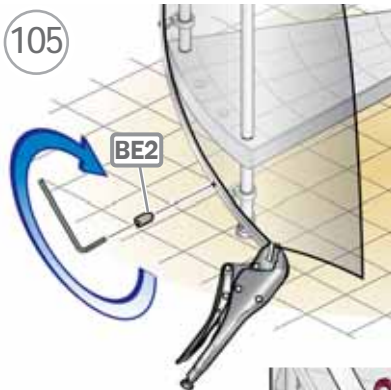

110

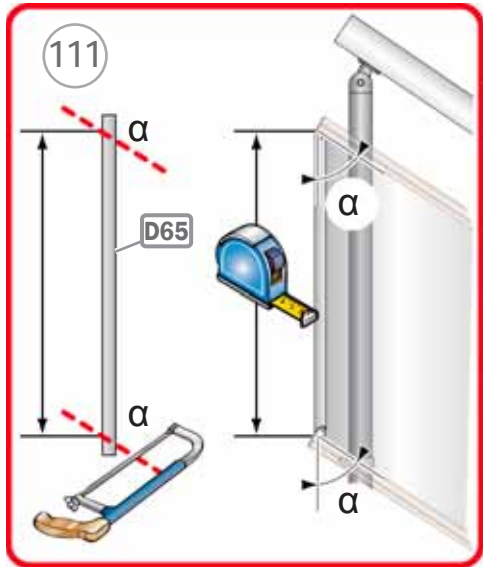
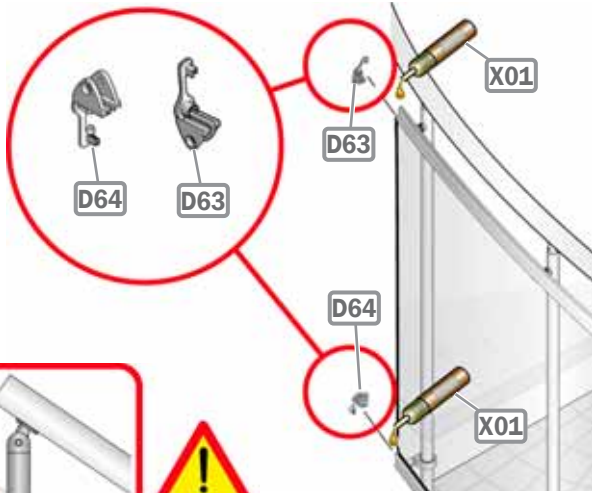

113



112

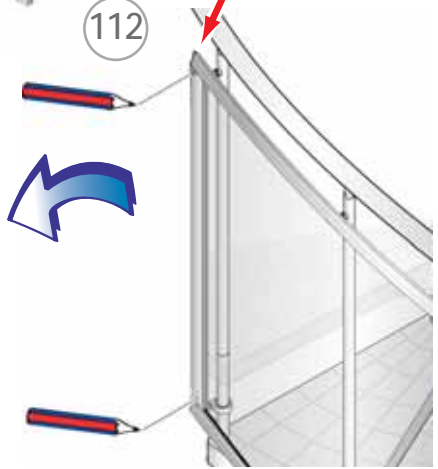

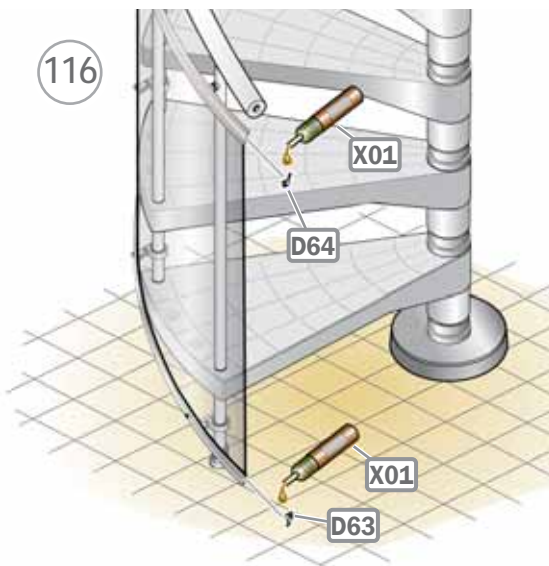
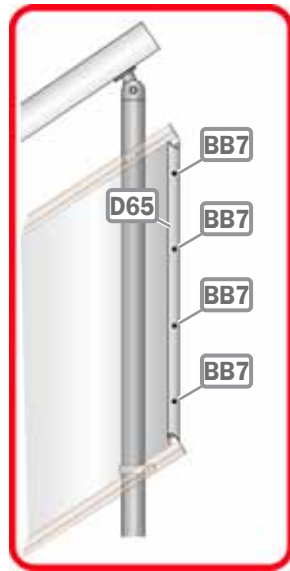
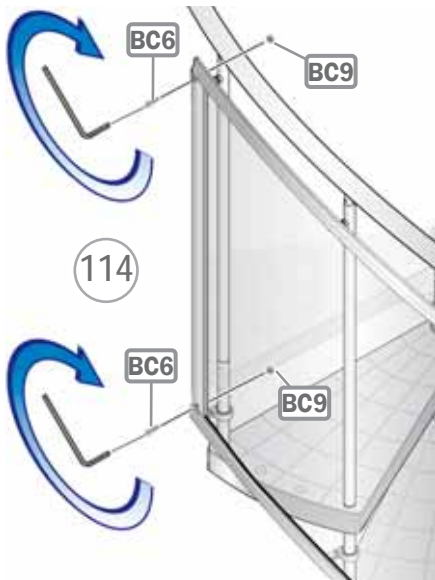

117

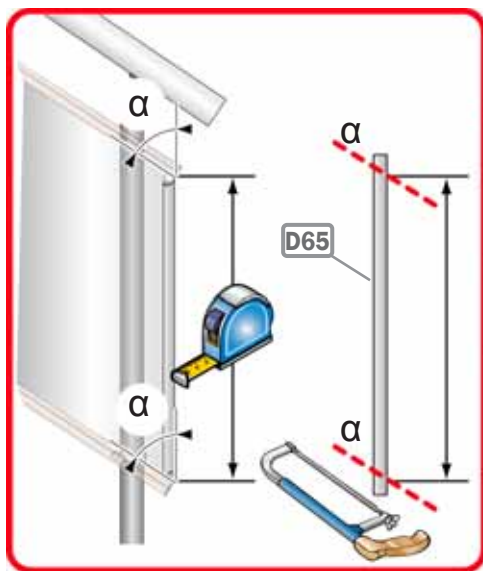

118

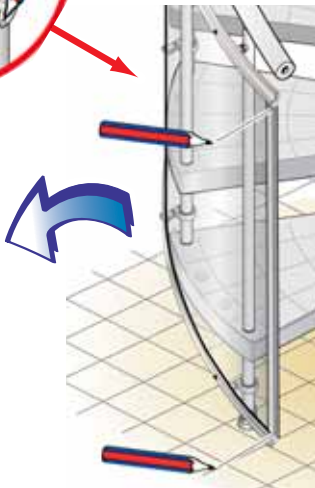

120

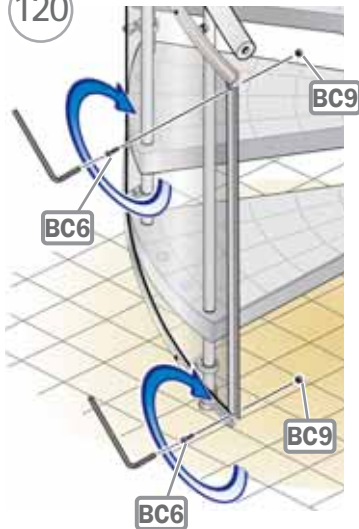

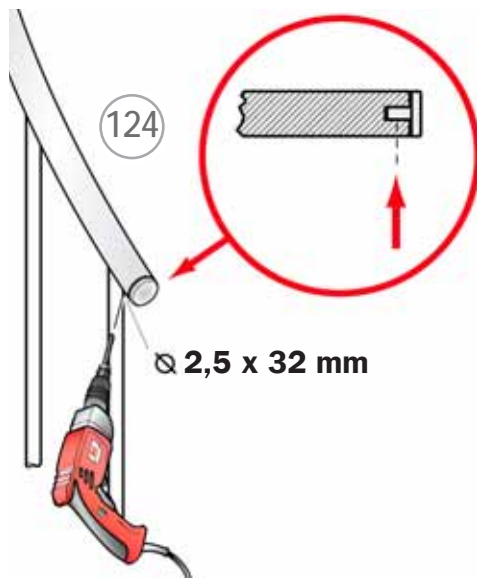
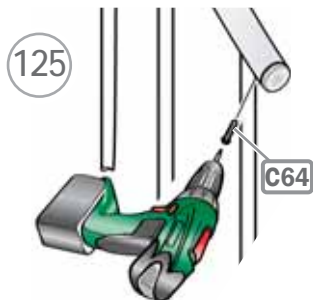
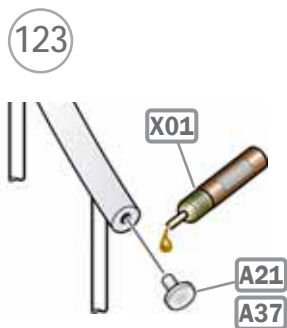
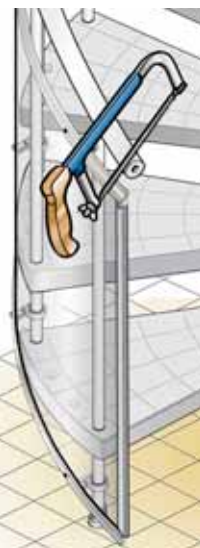
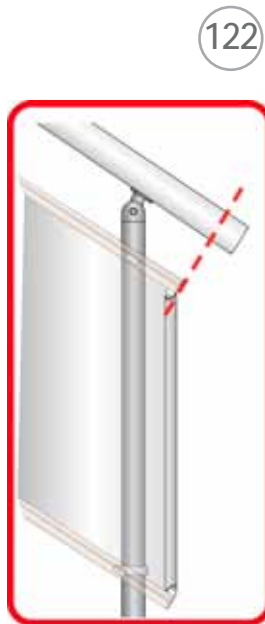
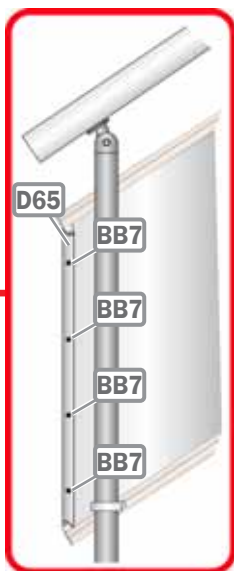

126

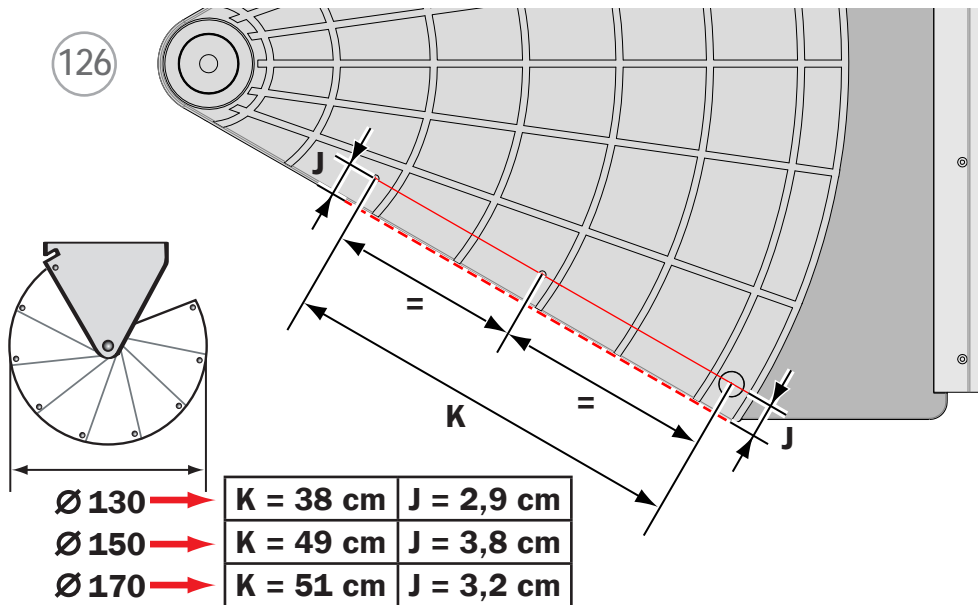

127

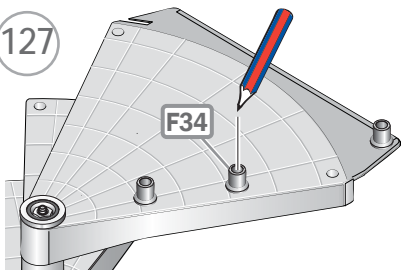

128

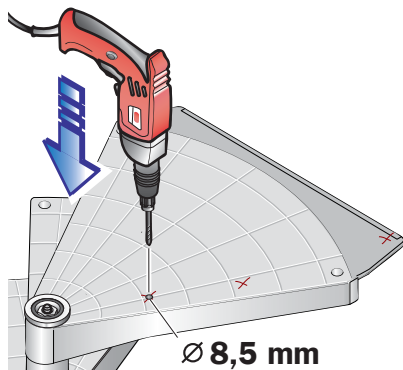

129

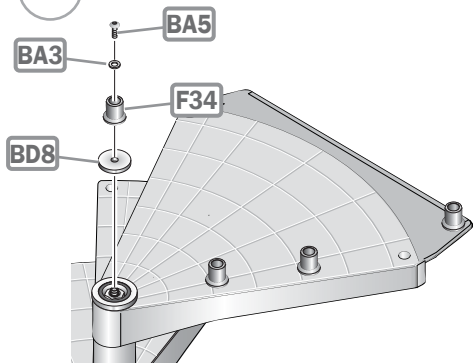

130

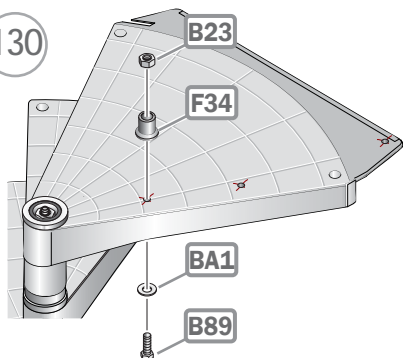

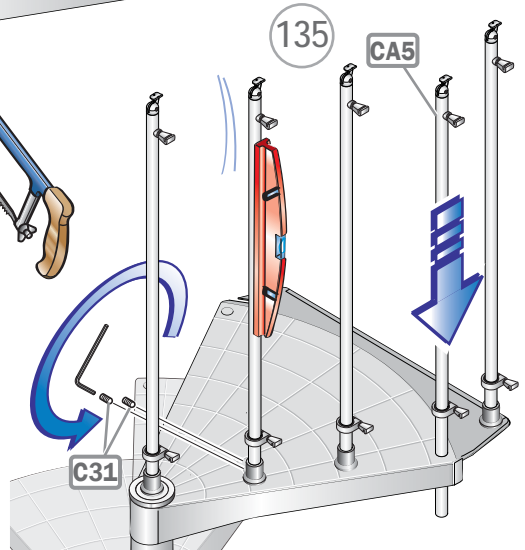
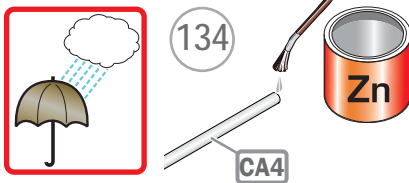
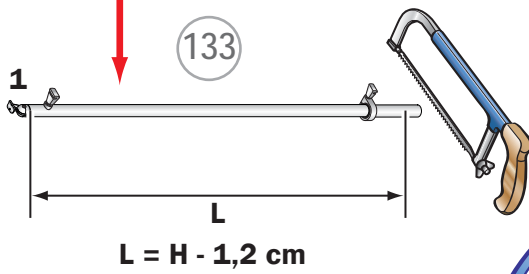
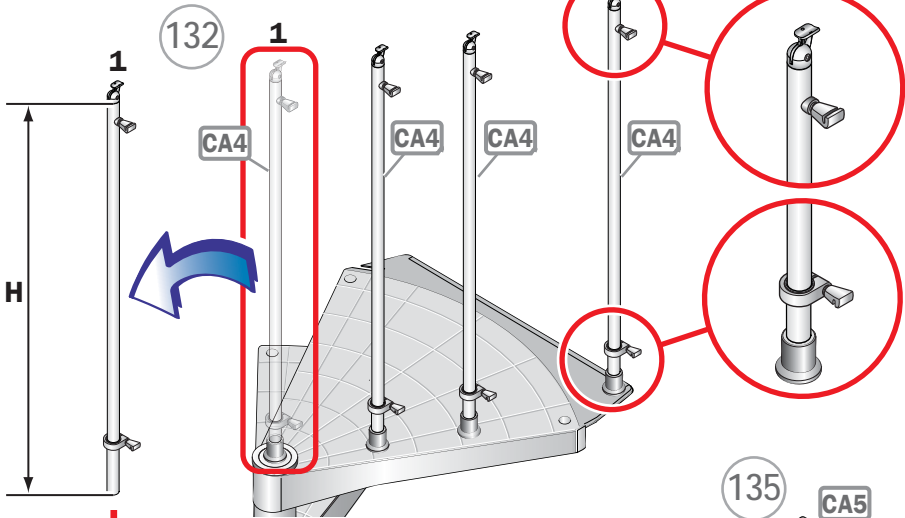
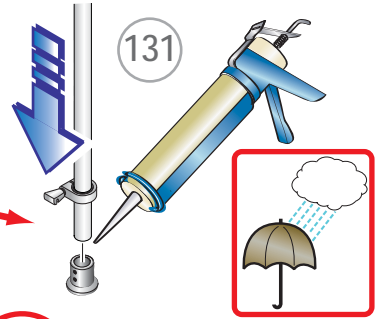
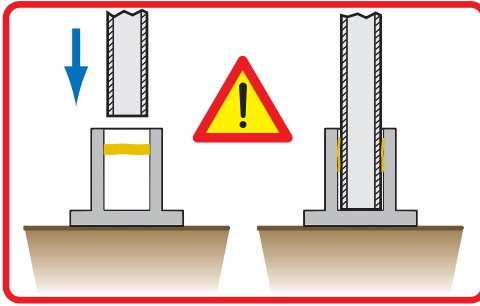

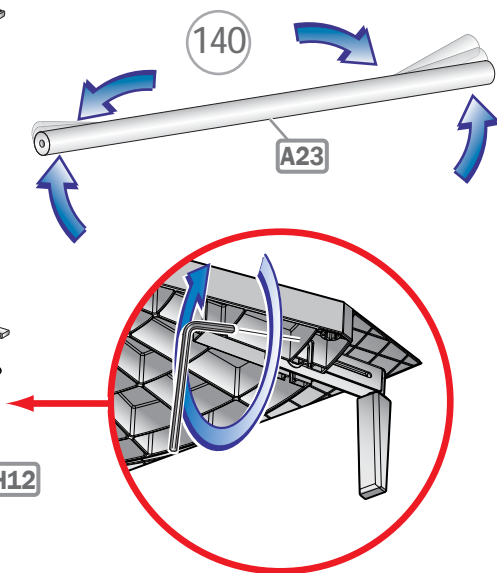
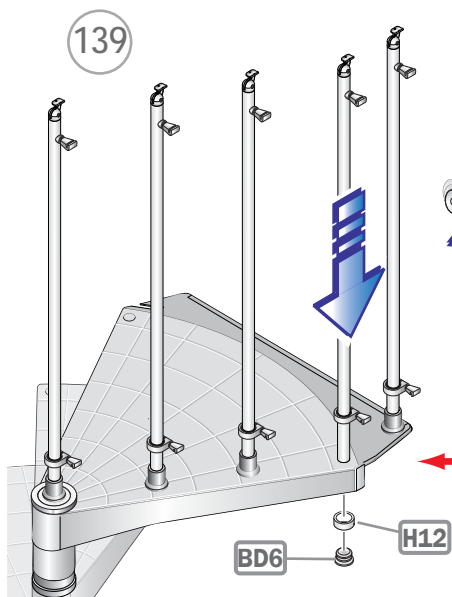
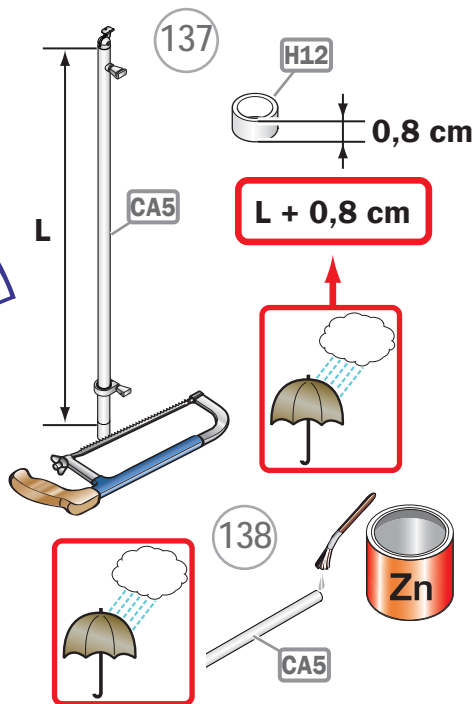
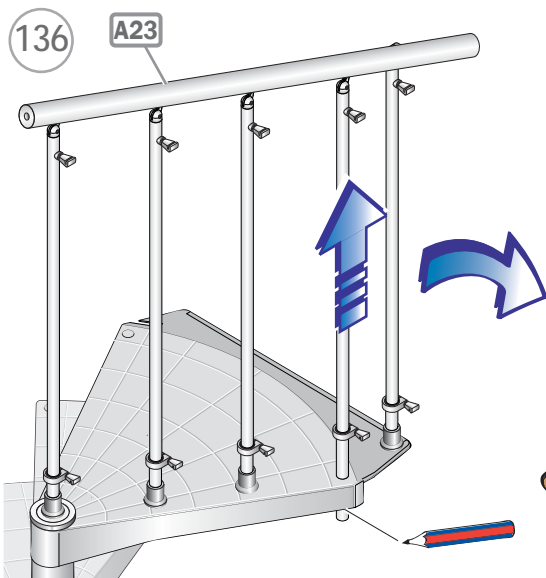



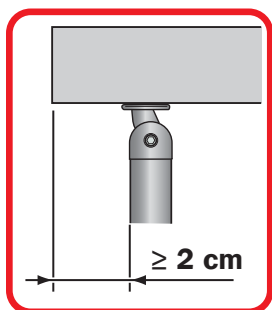

141

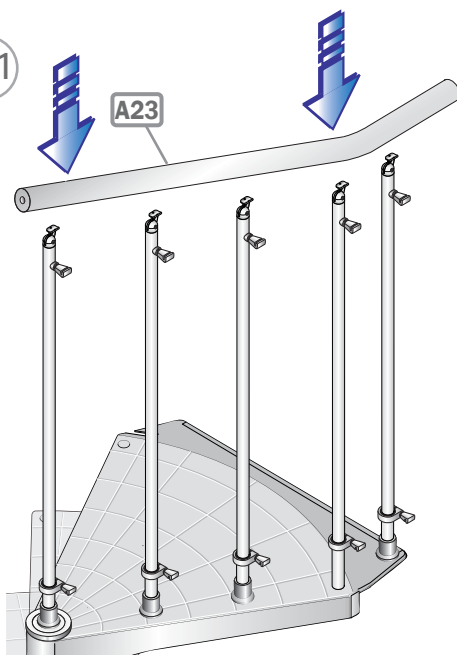

142

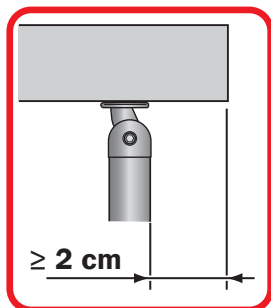
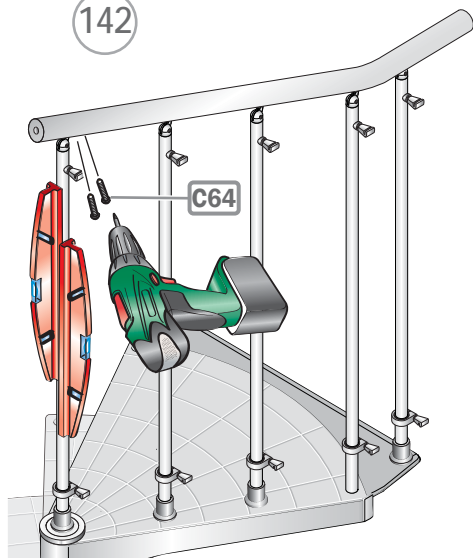

143

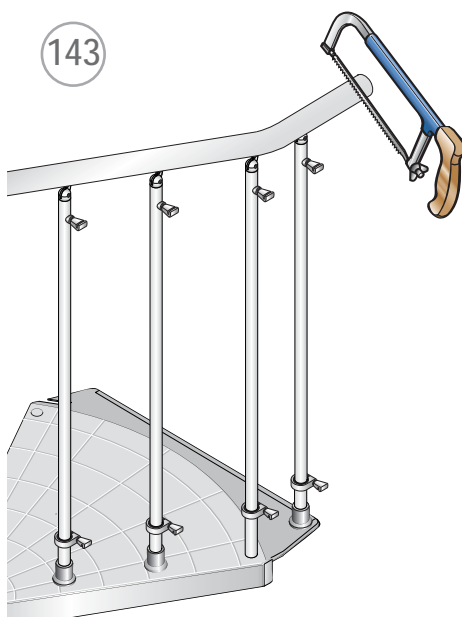

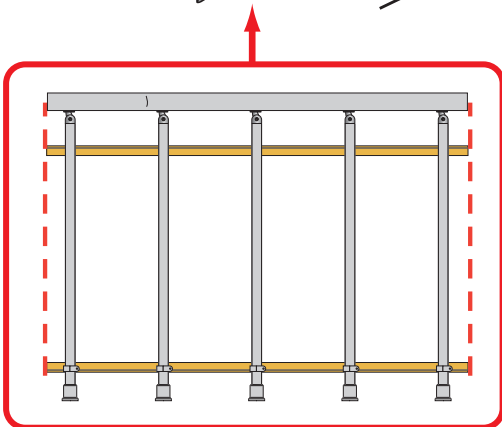
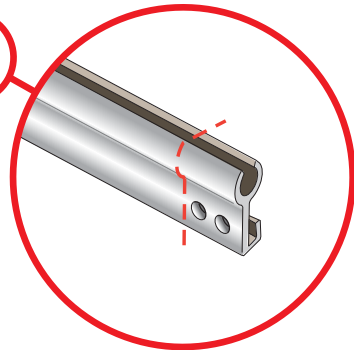
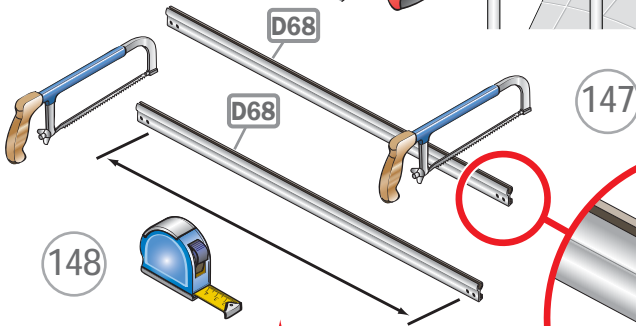
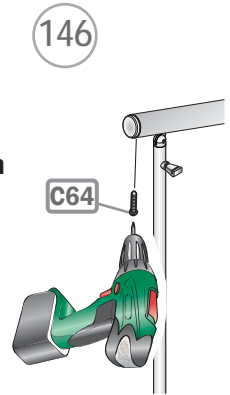
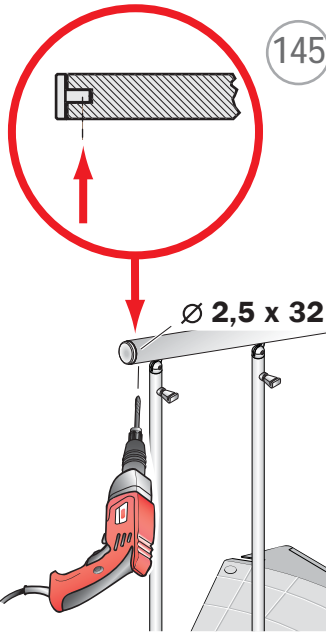
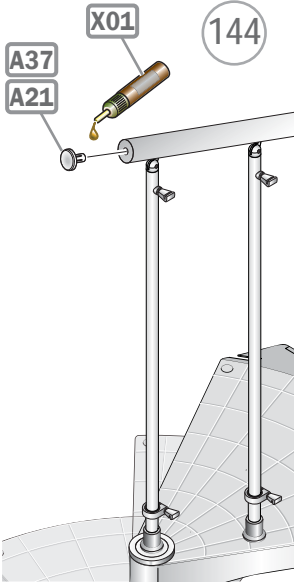

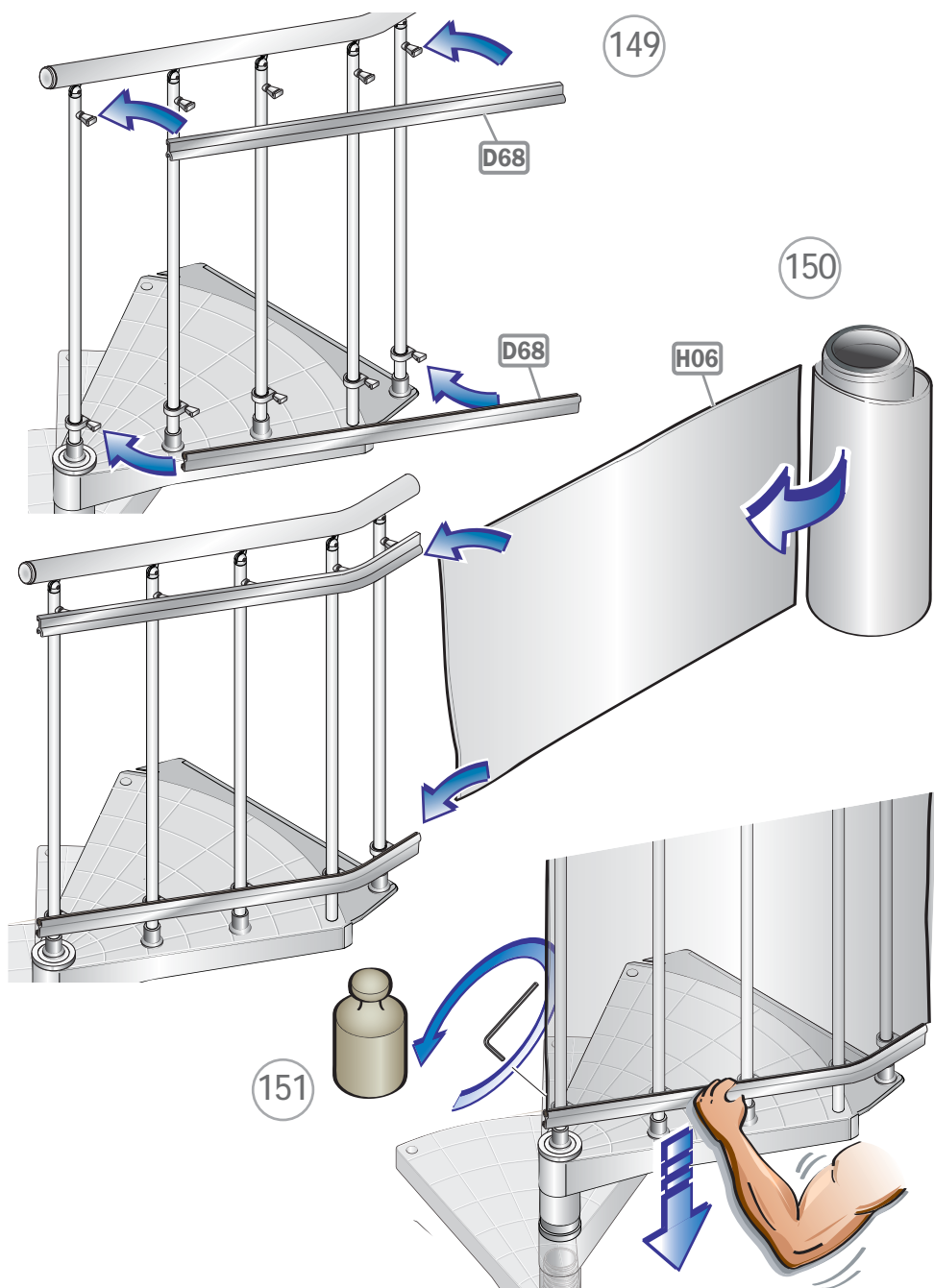

152

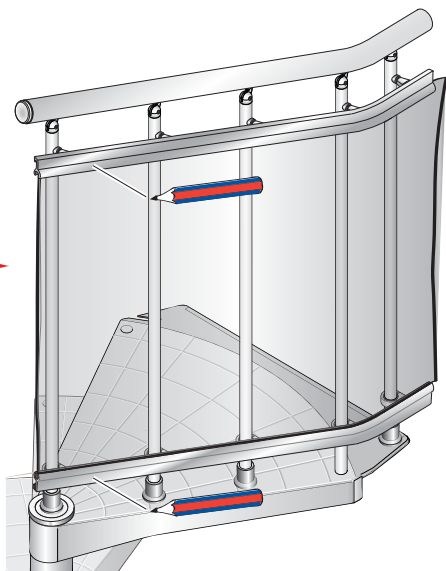
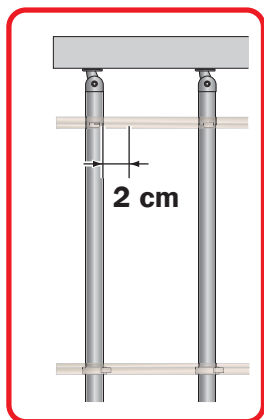

153

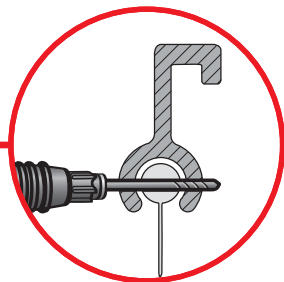
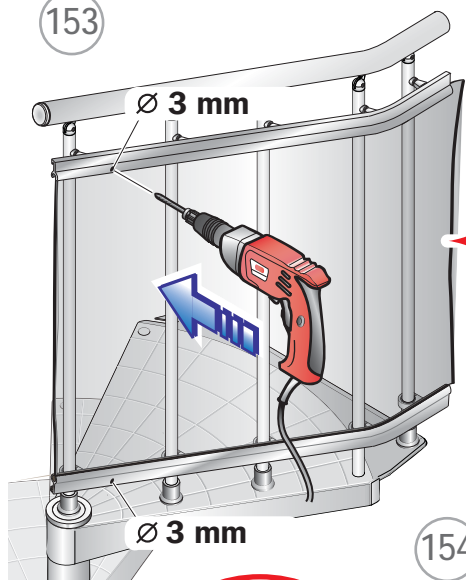

154

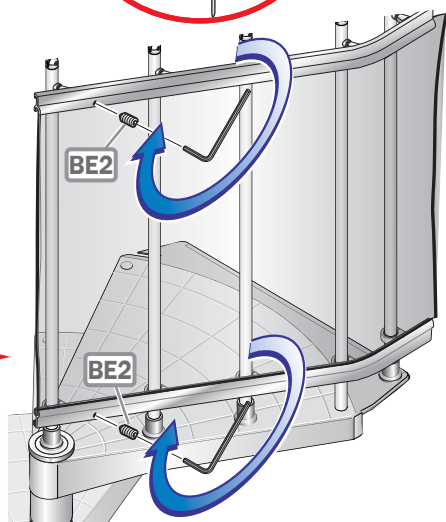
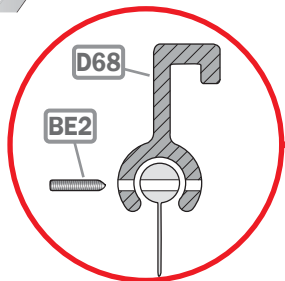

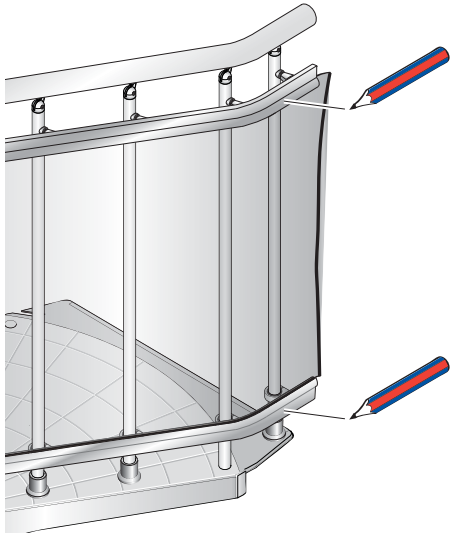

155

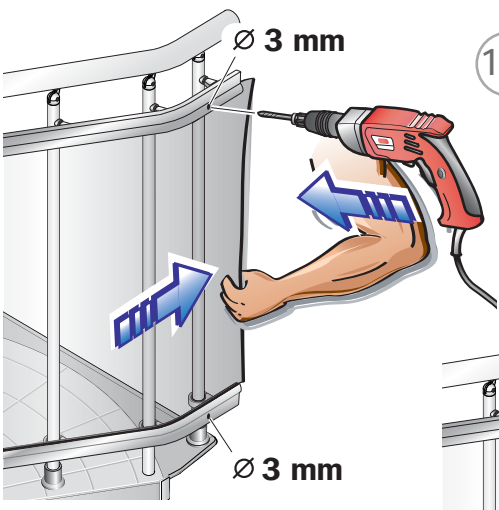
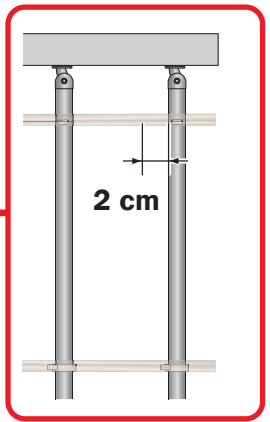

156

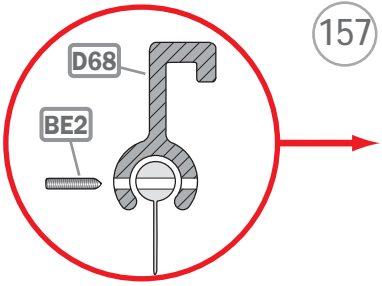
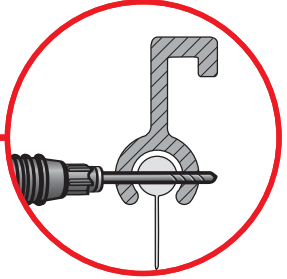

157

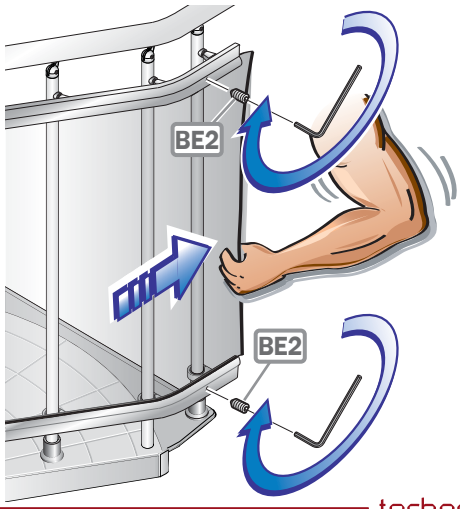

158

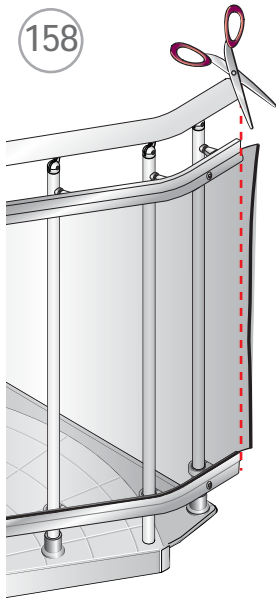

159

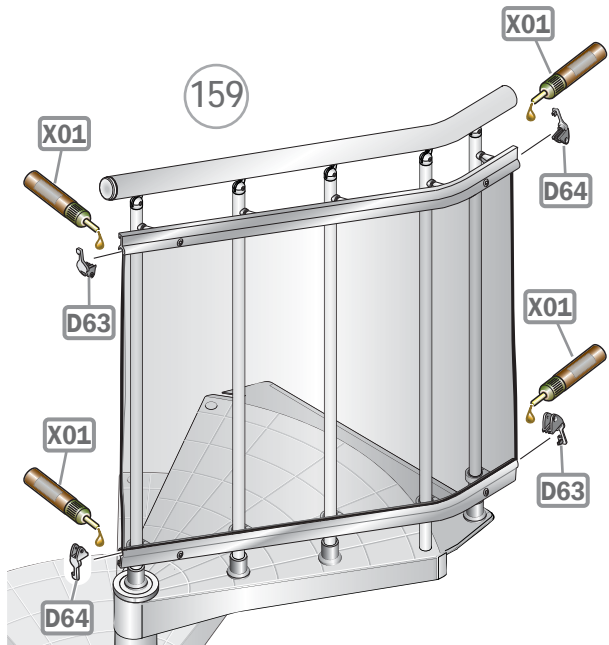

160

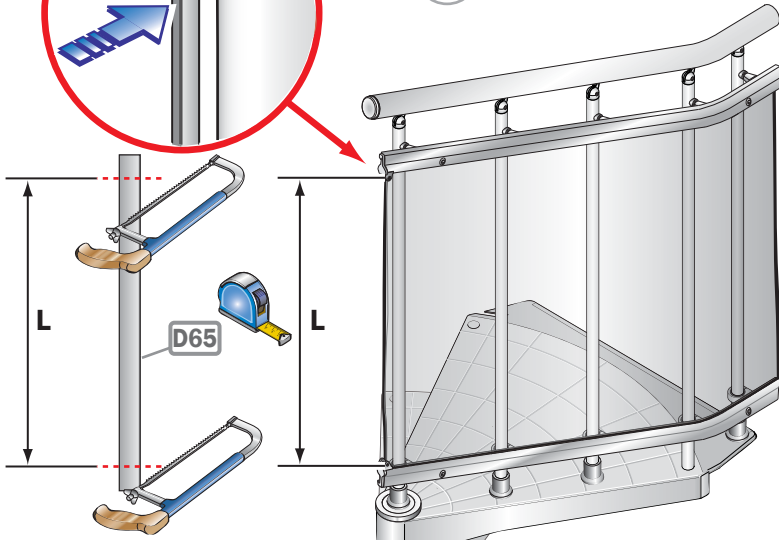

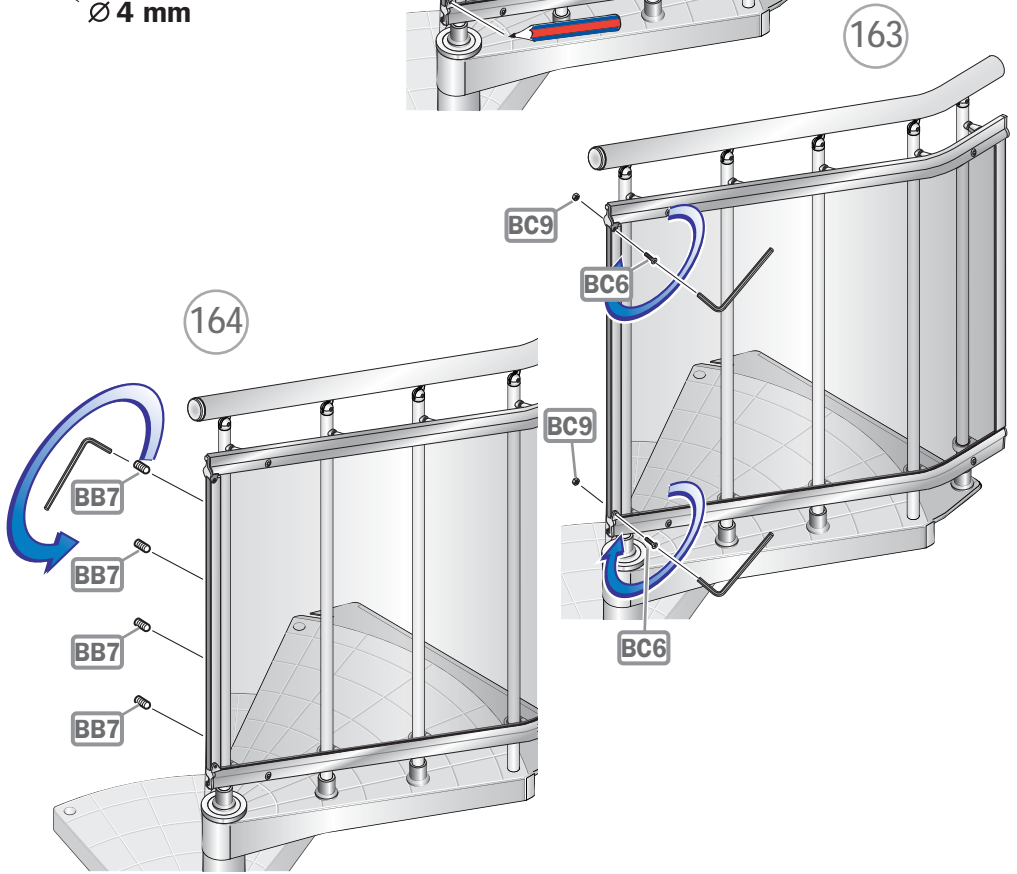
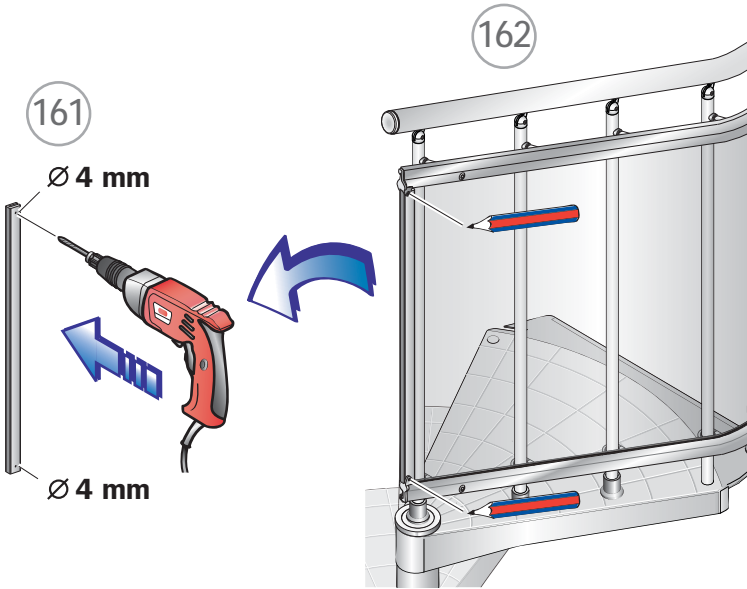

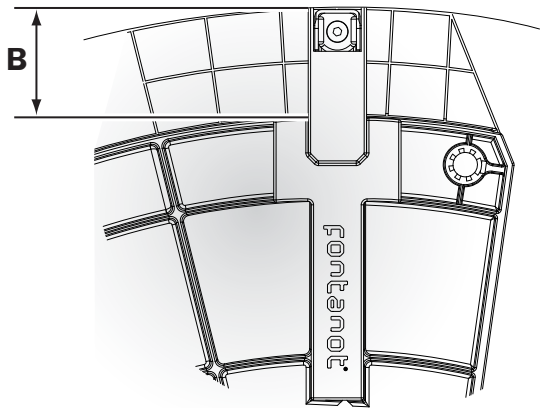
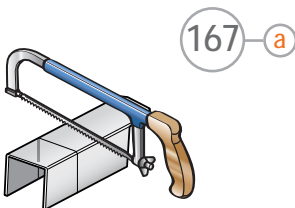
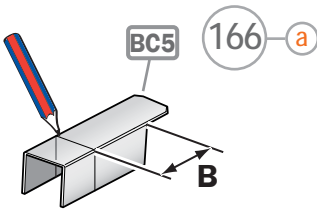
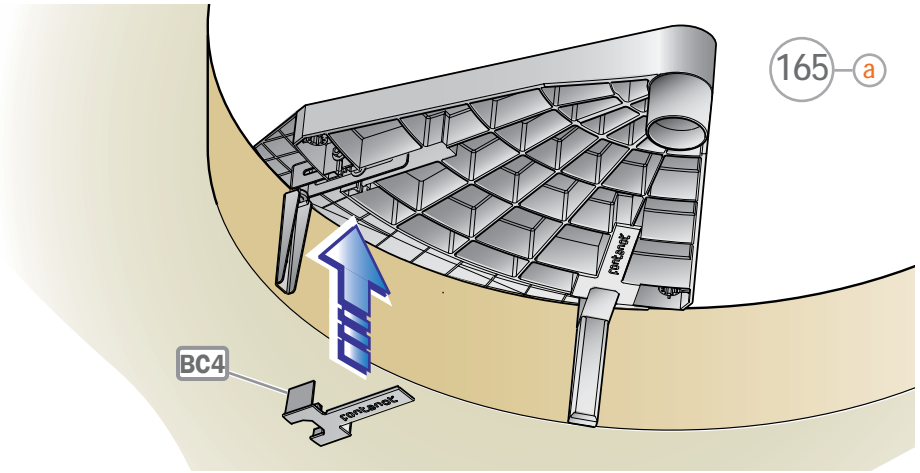
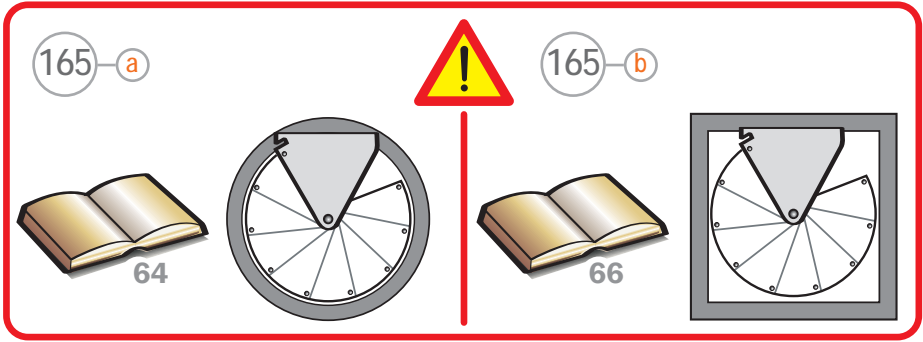



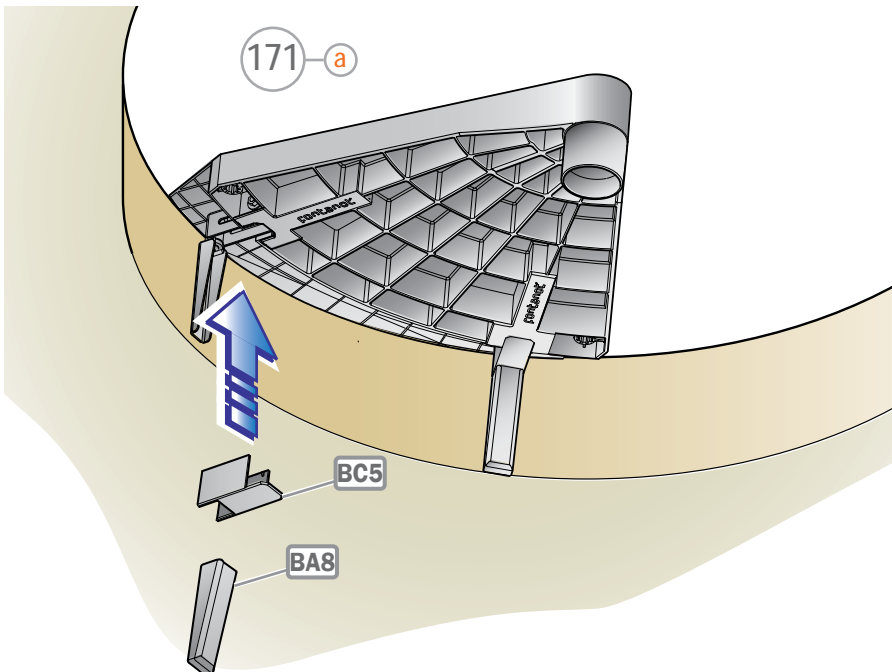
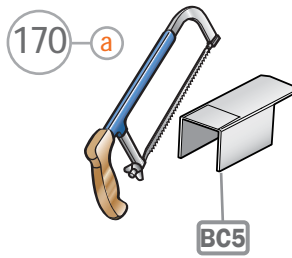
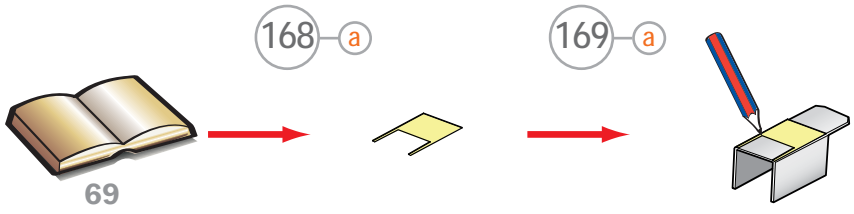

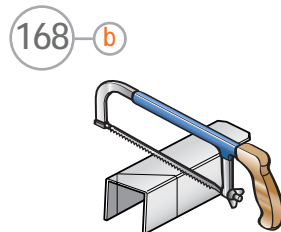
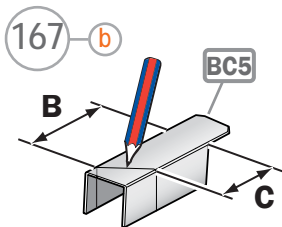
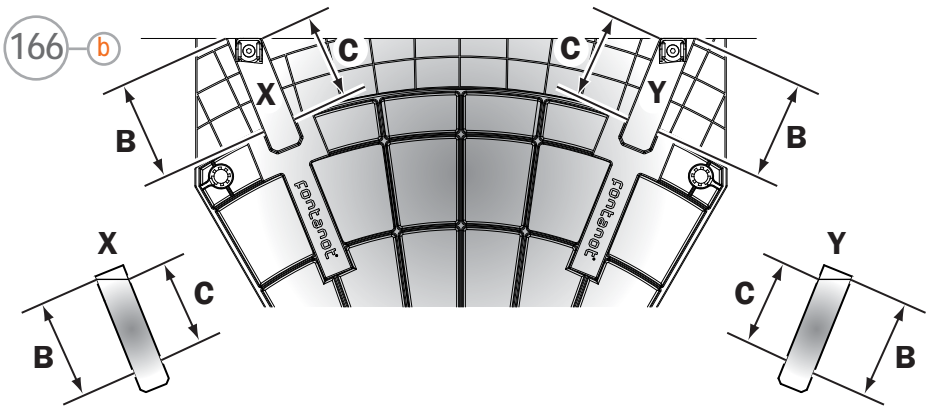
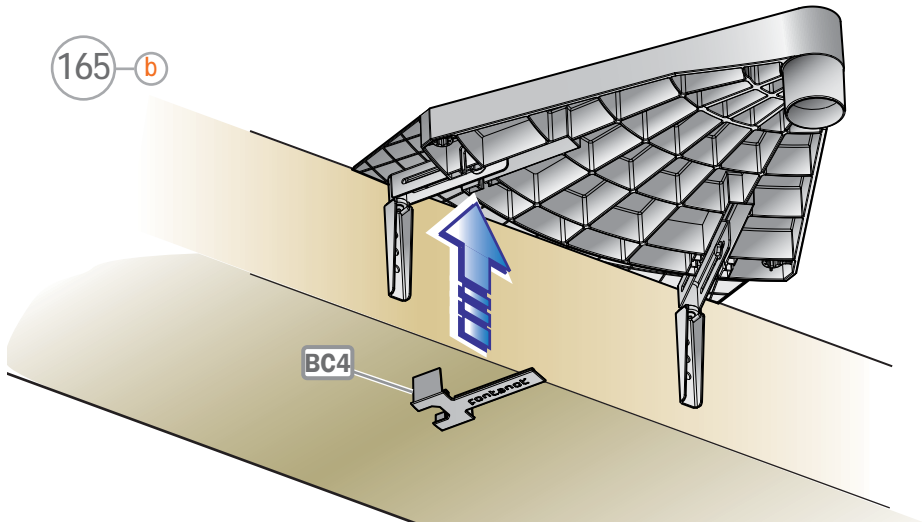

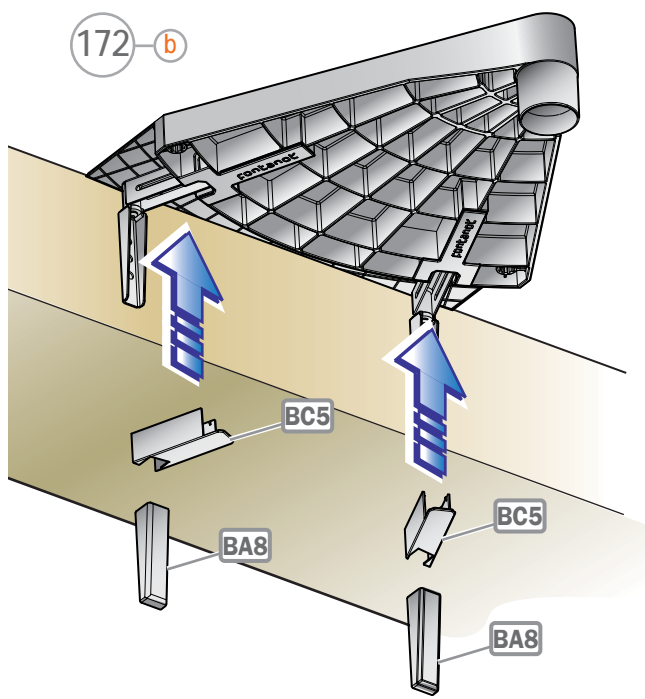
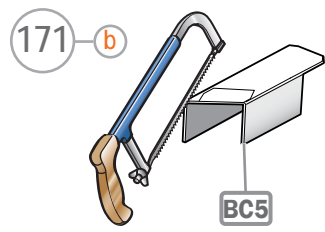
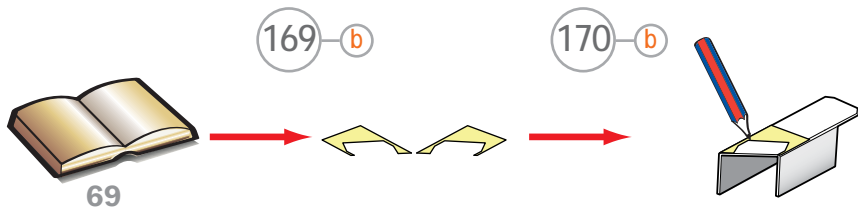

173

Ø8 x 50 mm

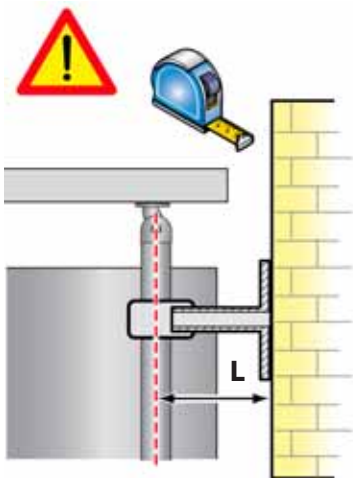
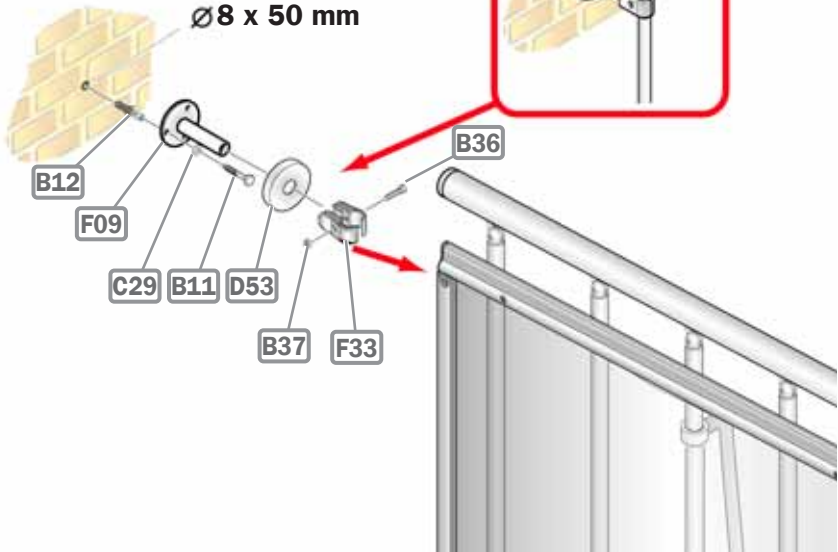

175

174

L - 3 cm

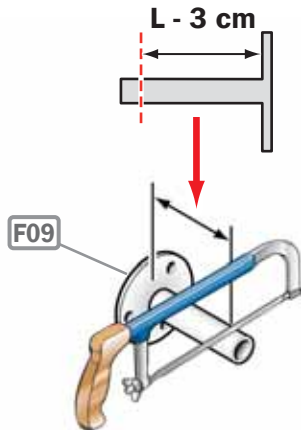

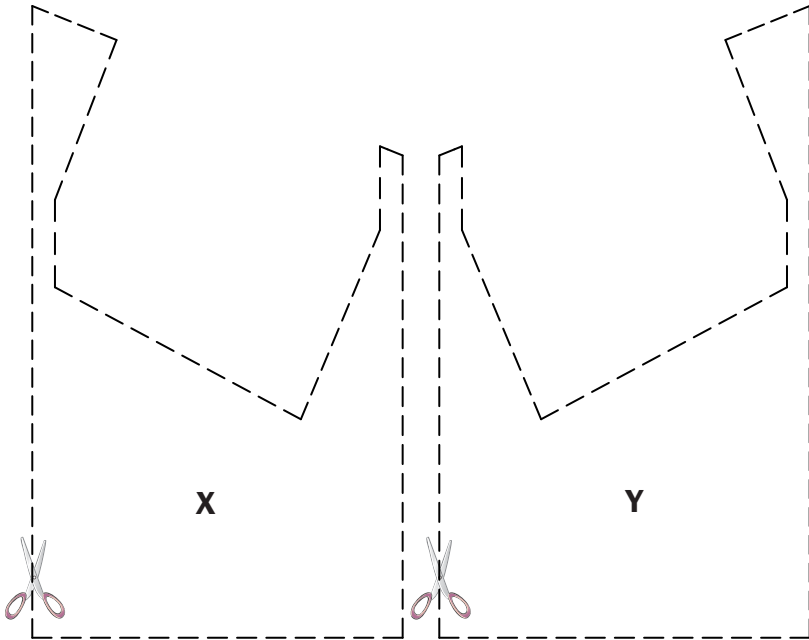
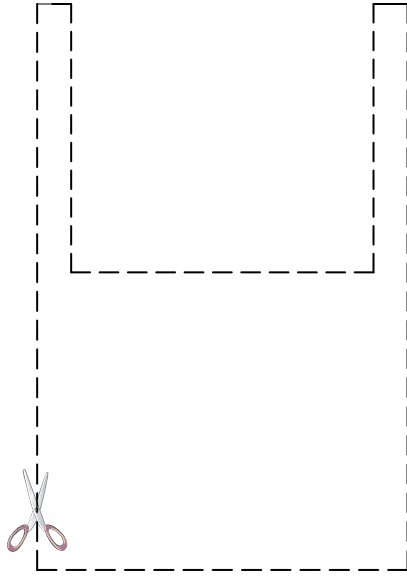





**Italiano**  
**English**  
**Deutsch**  
**Français**  
**Español**

DATI IDENTIFICATIVI DEL PRODOTTO  
PRODUCT DETAILS  
PRODUKTEIGENSCHAFTEN  
DONNÉES D'IDENTIFICATION DU PRODUIT  
DATOS DE IDENTIFICACIÓN



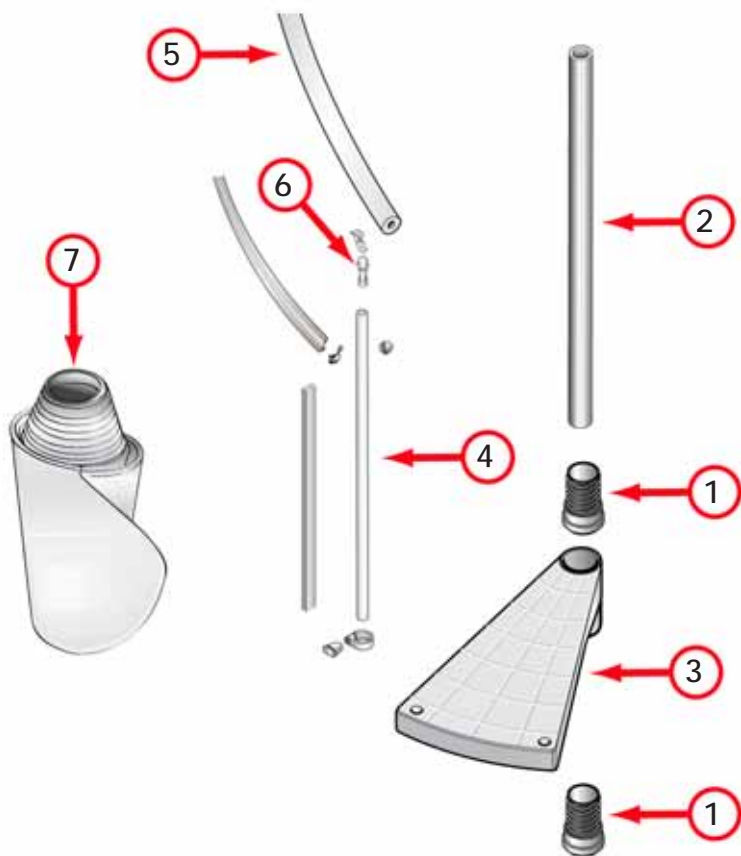



## IT)

### dati identificativi del prodotto

denominazione commerciale: **TECHNE SKIN**

tipologia: scala a chiocciola a pianta tonda

### materiali impiegati

#### STRUTTURA

##### descrizione

composta da distanziali **(1)** in tecnopolimero impilati e compressi sul palo **(2)** centrale modulare

##### materiali

distanziali: nylon

palo: Fe 370 zincato

#### GRADINI

##### descrizione

gradini **(3)** in tecnopolimero circolari impilati sul palo **(2)** centrale

##### materiali

nylon/polipropilene

#### RINGHIERA

##### descrizione

composta da colonnine **(4)** verticali in metallo fissate ai gradini **(3)**, da un telo **(7)** in polivinile e poliestere e da un corrimano **(5)** in PVC

##### materiali

colonnine **(4)**: Fe 370

corrimano **(5)**: PVC con anima in alluminio

telo **(7)**: polivinile + poliestere

fissaggi **(6)**: zama

##### finitura

colonnine **(4)** e fissaggi **(6)**: verniciatura a forno con polveri poliestere.

### PULIZIA E MANUTENZIONE OBBLIGATORIA

Eseguire la pulizia della scala alla prima comparsa di macchie di sporco e depositi di polvere e periodicamente almeno ogni 6 mesi con panno morbido inumidito in acqua e detersivi specifici non abrasivi ed aggressivi. NON usare mai pagliette abrasive o in ferro. Pulire ed asciugare accuratamente dopo il lavaggio con un panno in microfibra al fine di eliminare gli aloni del calcare presente nell'acqua. Dopo circa 12 mesi dalla data di installazione, controllare il serraggio della viteria dei vari componenti. Al verificarsi di qualsiasi minimo malfunzionamento è obbligatorio effettuare una manutenzione straordinaria, da eseguire subito e a regola d'arte.

### PRECAUZIONI D'USO

Evitare usi impropri e non consoni al prodotto, eventuali manomissioni o installazioni non rispondenti alle istruzioni del produttore possono inficiare le conformità prestabilite del prodotto.

## EN)

### product details

trade name: **TECHNE SKIN**

type: Spiral round staircase

### materials used

#### STRUCTURE

##### description

composed of technopolymer spacers **(1)** stacked and compressed on the modular central pole **(2)**

##### materials

spacers: nylon

pole: Fe 370 galvanized

#### TREADS

##### description

technopolymer circular treads **(3)** stacked on the central pole **(2)**

##### materials

nylon/polypropylene

#### RAILING

##### description

composed of vertical metal balusters **(4)** fixed to the treads **(3)**, a polyvinyl+polyester sheet **(7)** and a PVC handrail **(5)**

##### materials

balusters **(4)**: Fe 370

handrail **(5)**: PVC with aluminium core

sheet **(7)**: polyvinyl + polyester

fixings **(6)**: zamak

##### finish

balusters **(4)** and fixings **(6)**: polyester powder coated in furnace.

### OBLIGATORY CLEANING AND MAINTENANCE

Clean the treads as soon as dirt spots and dust deposits appear and at least every 6 months using a soft cloth moistened with water and specific nonabrasive and non-aggressive detergents. NEVER use abrasive scourers. After cleaning, thoroughly dry the surfaces with a microfibre cloth to remove the haloes that form because of the limestone in the water. Approximately 12 months from the date of installation, check tightness of the screws of the various components. Should even the smallest malfunction occur, it is obligatory to immediately and professionally carry out extraordinary maintenance.

### USE PRECAUTION

Avoid any improper use that is not in accordance with the product. Possible violations or installations which don't comply with the providers instructions can invalidate the agreed product conformities.

**DE)**

## **Produkteigenschaften**

kommerzielle Bezeichnung: **TECHNE SKIN**

Typologie: Spindeltrappe mit rundem Grundriss

### **verwendete Materialien**

#### **STRUKTUR**

##### **Beschreibung**

besteht aus übereinander gelegten und auf die modulare Treppenspindel (2) angepressten Distanzhülsen (1) aus Technopolymer

##### **Materialien**

Distanzhülsen: Nylon

Spindel: Fe 370 feuerverzinkt

#### **STUFEN**

##### **Beschreibung**

runde Stufen (3) aus Technopolymer, die übereinander auf der Zentralspindel (2) liegen

##### **Materialien**

Nylon/Polypropylen

#### **GELÄNDER**

##### **Beschreibung**

besteht aus vertikalen, auf den Stufen (3) befestigten Metallstäben (4), einer Netzplane (7) aus Polyvinyl und Polyester und einem Handlauf (5) aus PVC

##### **Materialien**

Geländerstäbe (4): Fe 370

Handlauf (5): PVC mit Aluminiumkern

Netzplane (7): Polyvinyl + Polyester

Befestigungsteile (6): Zamak

##### **Ausführung**

Geländerstäbe (4), und Befestigungsteile (6): Ofenlackierung mit Polyesterpulver.

### **REINIGUNG UND VORGESCHRIEBENE INSTANDHALTUNG**

Die Treppe sofort reinigen wenn Schmutzfl ecken und Staubansammlungen entstehen und sie mindestens alle 6 Monate mit einem weichen, mit Wasser und einem spezifischen, weder scheuernden, noch aggressiven Reinigungsmittel befeuchteten Lappen abzuwischen. NIEMALS scheuernde Eisenschwämme verwenden. Nach der Feuchtreinigung mit einem Mikrofasertuch sorgfältig nachtrocknen, um die Schlierenbildung durch kalkhaltiges Wasser zu vermeiden. 12 Monate nach der Montage das Anzugsmoment der Schrauben der verschiedenen Komponenten kontrollieren. Bei Auftreten einer noch so geringen Funktionsstörung muss unbedingt sofort eine fachgerechte außerordentliche Instandhaltung durchgeführt werden.

### **VORSICHTSMAßNAHMEN FÜR DIE ANWENDUNG**

Die falsche und unangemessene Verwendung des Produkts vermeiden. Eventuelle Beschädigungen oder nicht der Montageanleitung des Herstellers gemäße Einrichtungen können die vorgegebene Produktkonformität für ungültig erklären.

**FR)**

## **données d'identification du produit**

denomination commerciale: **TECHNE SKIN**

typologie: escalier helicoidal à plan rond

### **matériaux utilisés**

#### **STRUCTURE**

##### **description**

composé d'entretoises (1) en technopolymère empilées et comprimées sur le pylône (2) central modulaire

##### **matériaux**

entretoises: nylon

pylône: Fe 370 galvanisé

#### **MARCHES**

##### **description**

marches (3) en technopolymère circulaires empilées sur le pylône (2) central

##### **matériaux**

nylon/polypropylène

#### **GARDE-CORPS**

##### **description**

composé de colonnettes (4) verticales en métal, fixées aux marches (3), d'une toile (7) en polyvinyle et polyester et d'une main-courante (5) en PVC

##### **matériaux**

colonnettes (4): Fe 370

main-courante (5): PVC avec âme en aluminium

toile (7): polyvinyle + polyester

fixations (6): zama

##### **finition**

colonnettes (4) et fixations (6): peinture au four avec des poudres d'époxy.

### **NETTOYAGE ET MAINTENANCE OBLIGATOIRE**

Nettoyer les marches dès que des taches de saleté ou des dépôts de poussière apparaissent ; effectuer également un nettoyage périodique, tous les 6 mois, à l'aide d'un chiffon doux, humidifié d'eau et de détergents spécifiques non abrasifs et non agressifs. NE JAMAIS utiliser de la paille de fer abrasive. Après lavage, nettoyer et essuyer soigneusement avec un chiffon en microfibre, afin d'éliminer les auréoles provoquées par le calcaire contenu dans l'eau. Environ 12 mois après la date d'installation, contrôler le serrage des vis des différents composants. À la moindre défaillance, il est obligatoire d'effectuer immédiatement une maintenance corrective, dans les règles de l'art.

### **PRECAUTION D'UTILISATION**

Eviter l'utilisation impropre et non conforme au produit. D'éventuelles alterations ou installations non correspondantes aux instructions du producteur peuvent invalider les conformités préétablies du produit.

**ES)**

## **datos de identificación del producto**

denominación comercial: **TECHNE SKIN**

tipo: escalera de caracol de planta redonda

### **materiales empleados**

#### **ESTRUCTURA**

##### **descripción**

compuesta por distanciadores **(1)** de tecno-polímero apilados y comprimidos en el palo **(2)** central modular

##### **materiales**

distanciadores: nylon

palo: Fe 370 cincado

#### **PELDAÑOS**

##### **descripción**

peldaños **(3)** circulares de tecno-polímero apilados en el palo **(2)** central

##### **materiales**

nylon/polipropileno

#### **BARANDILLA**

##### **descripción**

compuesta por barrotes **(4)** verticales de metal fijados en los peldaños **(3)**, una tela **(7)** de polivinilo y poliéster y un pasamanos **(5)** de PVC

##### **materiales**

barrotes **(4)**: Fe 370

pasamanos **(5)**: PVC con alma de aluminio

tela **(7)**: polivinilo + poliéster

fijaciones **(6)**: zamak

##### **acabado**

barrotes **(4)** y fijaciones **(6)**: barnizado al horno con polvos de poliéster.

#### **LIMPIEZA Y MANTENIMIENTO OBLIGATORIO**

Realizar la limpieza de la escalera en cuanto aparezcan manchas de suciedad y depósitos de polvo, y periódicamente al menos cada 6 meses, con un paño suave humedecido en agua y detergentes específicos no abrasivos ni agresivos. NO utilizar nunca lanas abrasivas o de hierro. Limpiar y secar bien después del lavado utilizando un paño de microfibra para eliminar las aureolas de cal dejadas por el agua. Transcurridos unos 12 meses desde la fecha de instalación, comprobar que los tornillos que fijan las distintas partes sigan bien apretados. Ante el menor defecto de funcionamiento, es obligatorio realizar un mantenimiento extraordinario según las reglas del arte.

#### **PRECAUCIONES DE USO**

Evitar usos impropios y no conformes con el producto. Eventuales manipulaciones o instalaciones que no cumplan con las instrucciones del fabricante pueden menoscabar las cualidades certificadas en las pruebas de conformidad a las que previamente fue sometido el producto.



**TE SKIN**

D.U.M  
01/2016

techne

Fontanot S.p.A.  
**Sede legale ed amministrativa**  
via P. Paolo Pasolini, 6  
47853 Cerasolo Ausa  
Rimini, Italy

tel. +39.0541.90.61.11  
fax. +39.0541.90.61.24  
info@technestairs.com  
www.technestairs.com

cod. 066223000

Design: Centro Ricerche Fontanot

**ADIMEMBER**

Sistema aziendale Fontanot S.p.A.  
certificato CSQ ISO-9001

