

STYLE:

smart

Magia30

fontanot[®]
magia





IT) ATTENZIONE!

Leggere e seguire scrupolosamente queste istruzioni e tenere per future consultazioni.
Eseguire l'installazione "a regola d'arte", utilizzando attrezzi idonei; seguire scrupolosamente le istruzioni di montaggio. Informarsi prima dell'installazione, sui regolamenti locali e nazionali da rispettare, in funzione della destinazione d'uso (privato principale, secondario, uffici, negozi,...).

EN) WARNING!

Carefully read and strictly follow these instruction and keep them for future consultation.
Carry out the installation in a "workmanlike" manner, strictly following the installation instructions and using suitable tools. Always consult your local building department for code requirements that must be respected depending on its destination of use (private, secondary, public...).

DE) ACHTUNG!

Lesen sie diese Anleitung sorgfältig durch und heben sie sie für spätere Zwecke auf.
Die Montage muss fachgerecht, unter Zuhilfenahme geeigneter Hilfsmittel und unter strikter Einhaltung der Montageanleitung ausgeführt werden. Damit die Montage normgerecht erfolgen kann, muss man zuvor Informationen zur Aufstellung und zu den lokal und national geltenden Vorschriften je nach Bestimmungszweck (privat, Haupt- oder Nebeneinrichtung, Büros, Geschäfte, ...) einholen.

FR) ATTENTION !

Lire et respecter scrupuleusement les présentes instructions ; les conserver pour toute autre consultation.
Effectuer l'installation dans les règles de l'art en utilisant des outils appropriés ; suivre scrupuleusement les instructions de montage. Pour réaliser un montage conforme aux normes en vigueur, il faut s'informer avant l'installation quant aux réglementations locales et nationales à respecter, en fonction du domaine d'utilisation (résidence privée principale, secondaire, bureaux, magasins,...).

ES) ¡ATENCIÓN!

Leer y seguir estrictamente estas instrucciones y conservarlas para consultas futuras.
Realizar la instalación "según las reglas del arte", utilizando herramientas adecuadas; seguir estrictamente las instrucciones de montaje. Informarse antes de la instalación sobre los reglamentos locales y nacionales a respetar, en función del destino de uso (privado principal, secundario, oficinas, tiendas,...).



10 mm
13 mm
19 mm

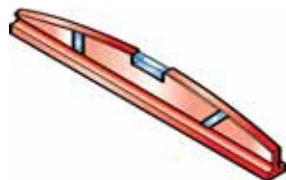

3 mm
5 mm
6 mm
10 mm

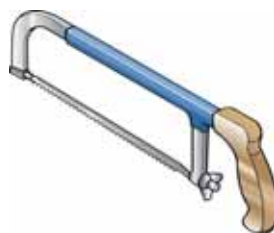

PH 2



Ø 2,5 mm
Ø 6,5 mm



Ø 8 x 120 mm
Ø 14 x 150 mm

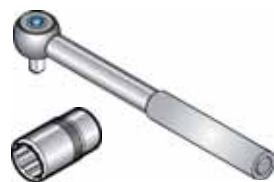

10 mm
13 mm
19 mm

1

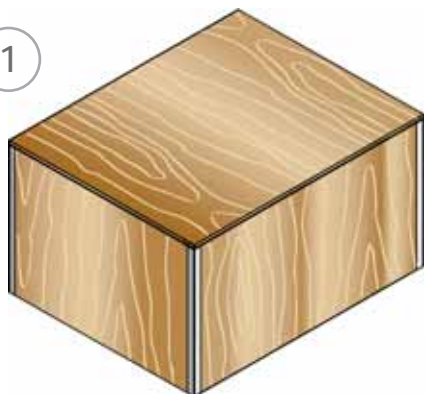

2

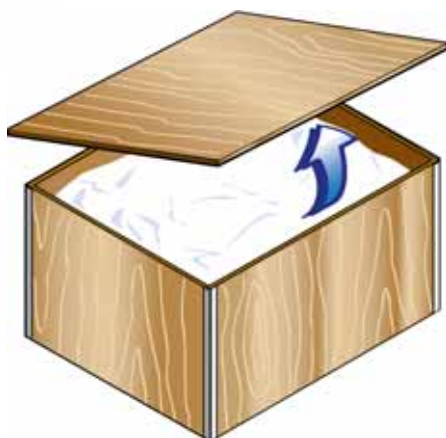

3

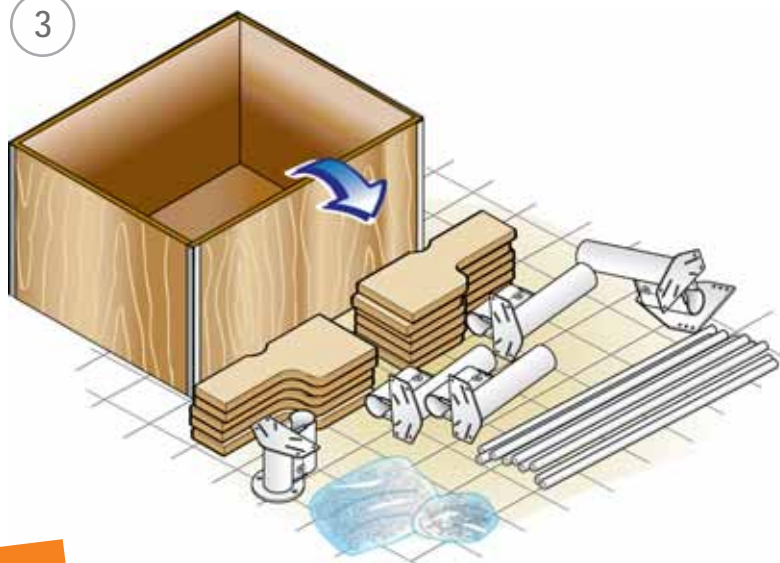

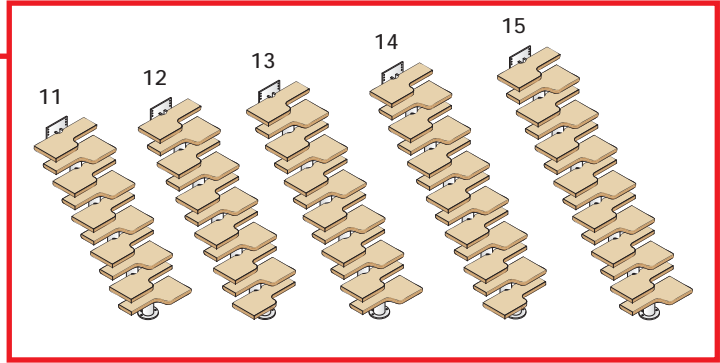
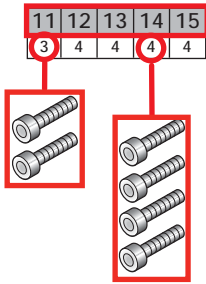

<p>A22</p> <table border="1"> <tr><td>11</td><td>12</td><td>13</td><td>14</td><td>15</td></tr> <tr><td>3</td><td>4</td><td>4</td><td>4</td><td>4</td></tr> </table>	11	12	13	14	15	3	4	4	4	4	<p>A37</p> <table border="1"> <tr><td>11</td><td>12</td><td>13</td><td>14</td><td>15</td></tr> <tr><td>2</td><td>2</td><td>2</td><td>2</td><td>2</td></tr> </table>	11	12	13	14	15	2	2	2	2	2	<p>B02</p> <table border="1"> <tr><td>11</td><td>12</td><td>13</td><td>14</td><td>15</td></tr> <tr><td>23</td><td>25</td><td>27</td><td>29</td><td>31</td></tr> </table>	11	12	13	14	15	23	25	27	29	31
11	12	13	14	15																												
3	4	4	4	4																												
11	12	13	14	15																												
2	2	2	2	2																												
11	12	13	14	15																												
23	25	27	29	31																												
<p>B12</p> <table border="1"> <tr><td>11</td><td>12</td><td>13</td><td>14</td><td>15</td></tr> <tr><td>4</td><td>4</td><td>4</td><td>4</td><td>4</td></tr> </table>	11	12	13	14	15	4	4	4	4	4	<p>B33</p> <table border="1"> <tr><td>11</td><td>12</td><td>13</td><td>14</td><td>15</td></tr> <tr><td>2</td><td>3</td><td>3</td><td>3</td><td>3</td></tr> </table>	11	12	13	14	15	2	3	3	3	3	<p>B71</p> <table border="1"> <tr><td>11</td><td>12</td><td>13</td><td>14</td><td>15</td></tr> <tr><td>18</td><td>20</td><td>22</td><td>24</td><td>26</td></tr> </table>	11	12	13	14	15	18	20	22	24	26
11	12	13	14	15																												
4	4	4	4	4																												
11	12	13	14	15																												
2	3	3	3	3																												
11	12	13	14	15																												
18	20	22	24	26																												
<p>B75</p> <table border="1"> <tr><td>11</td><td>12</td><td>13</td><td>14</td><td>15</td></tr> <tr><td>36</td><td>40</td><td>44</td><td>48</td><td>52</td></tr> </table>	11	12	13	14	15	36	40	44	48	52	<p>B82</p> <table border="1"> <tr><td>11</td><td>12</td><td>13</td><td>14</td><td>15</td></tr> <tr><td>10</td><td>11</td><td>12</td><td>13</td><td>14</td></tr> </table>	11	12	13	14	15	10	11	12	13	14	<p>B83</p> <table border="1"> <tr><td>11</td><td>12</td><td>13</td><td>14</td><td>15</td></tr> <tr><td>44</td><td>48</td><td>52</td><td>56</td><td>60</td></tr> </table>	11	12	13	14	15	44	48	52	56	60
11	12	13	14	15																												
36	40	44	48	52																												
11	12	13	14	15																												
10	11	12	13	14																												
11	12	13	14	15																												
44	48	52	56	60																												

C03



11	12	13	14	15
11	12	13	14	15

C13



11	12	13	14	15
22	24	26	28	30

C14



11	12	13	14	15
22	24	26	28	30

C15



11	12	13	14	15
18	20	22	24	26

C39



11	12	13	14	15
4	4	4	4	4

C49



11	12	13	14	15
23	25	27	29	31

C50



11	12	13	14	15
1	1	1	1	1

C57



11	12	13	14	15
40	44	48	52	56

C58



11	12	13	14	15
4	4	4	4	4

C63



11	12	13	14	15
11	12	13	14	15

C64



11	12	13	14	15
24	26	28	30	32

C65



11	12	13	14	15
11	12	13	14	15

C66



11	12	13	14	15
11	12	13	14	15

D72



11	12	13	14	15
2	3	3	3	3

F01



11	12	13	14	15
1	1	1	1	1

F08



11	12	13	14	15
2	2	2	2	2

F09



11	12	13	14	15
1	1	1	1	1

F23



11	12	13	14	15
22	24	26	28	30

L41

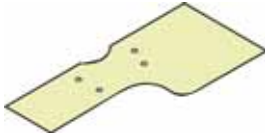

11	12	13	14	15
1	1	1	1	1

L44



11	12	13	14	15
10	11	12	13	14

N16



11	12	13	14	15
1	1	1	1	1

N17



11	12	13	14	15
1	1	1	1	1

N18

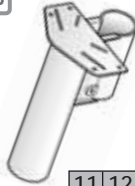

11	12	13	14	15
7	8	9	10	11

N19



11	12	13	14	15
1	1	1	1	1

X01



4

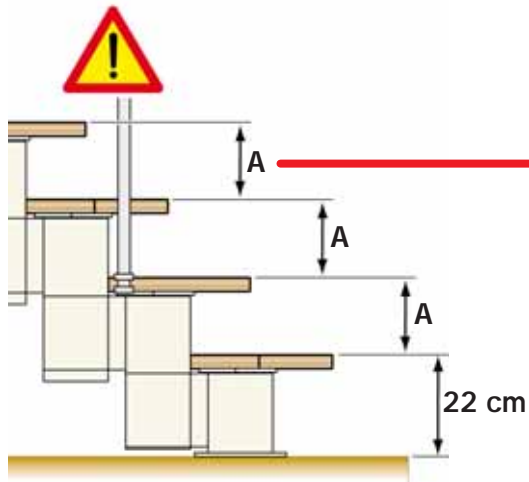

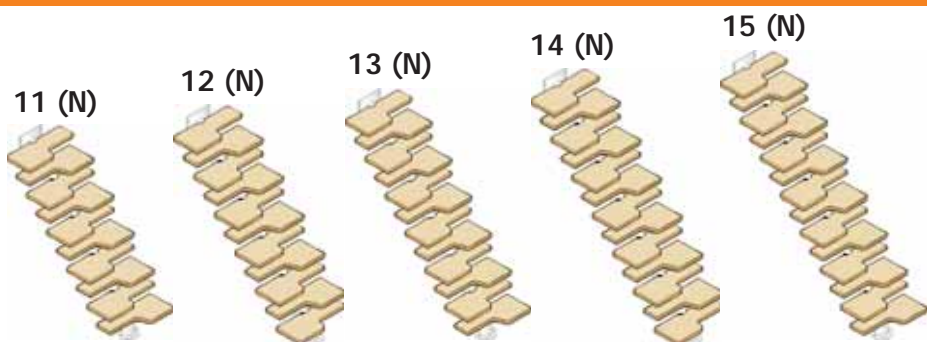

$$A = H - 22 \text{ cm} / N - 1 \quad (A = 19 \div 23,5 \text{ cm})$$

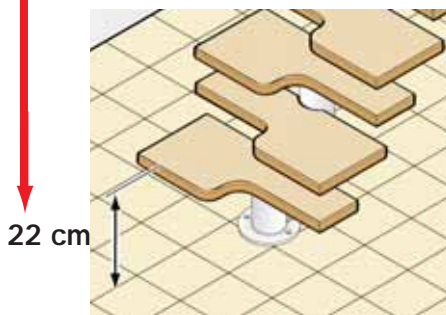
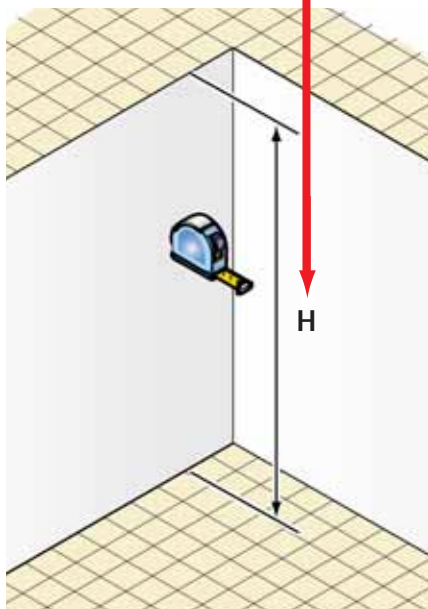

5

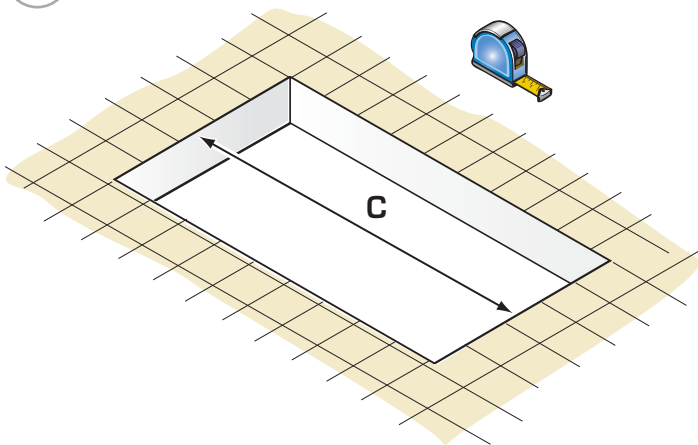

6 a

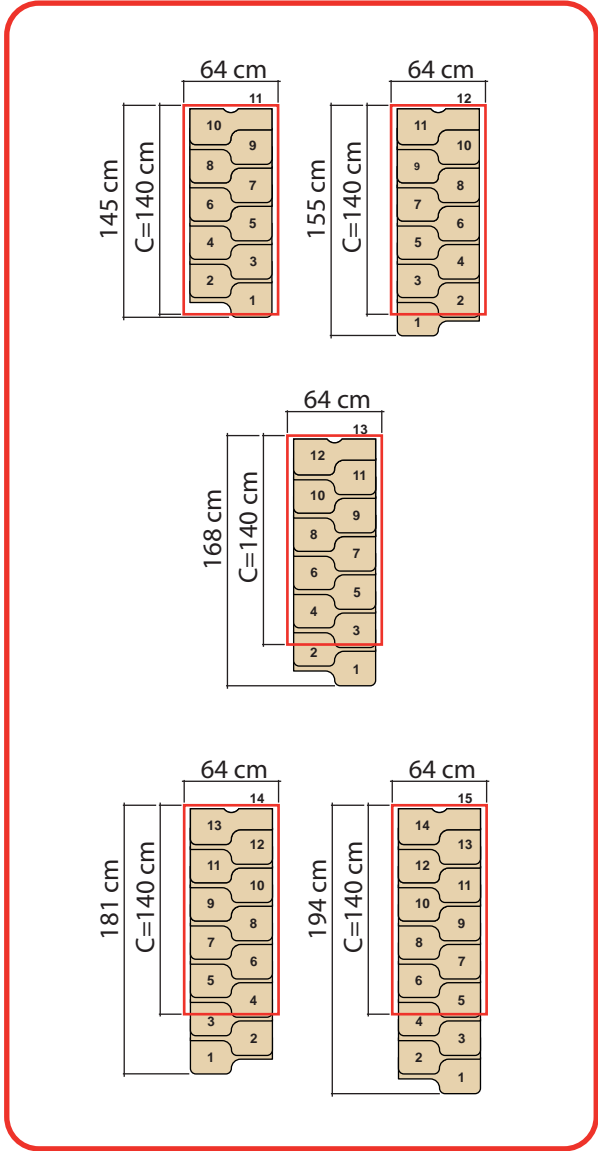

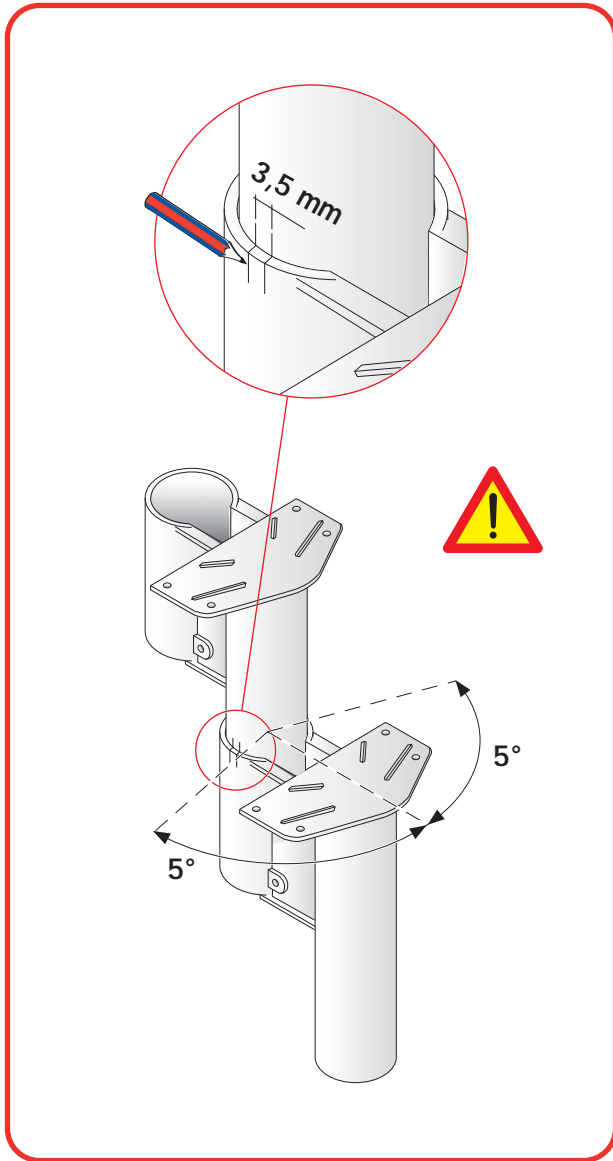

6 b

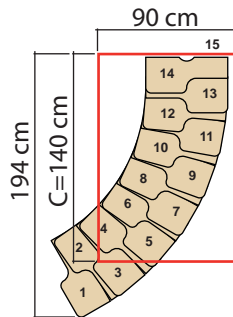
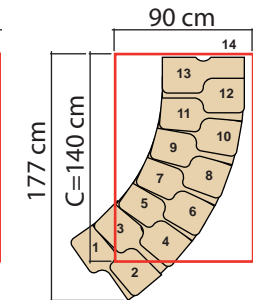
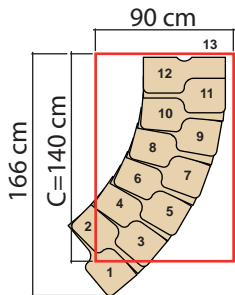
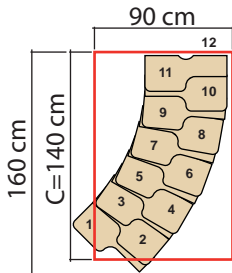
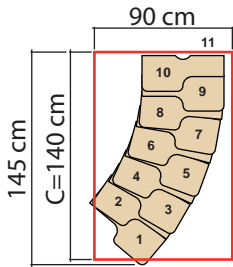
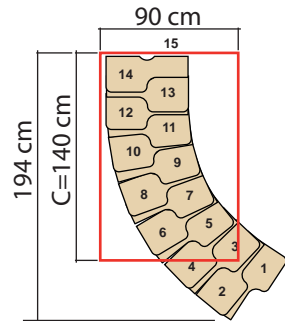
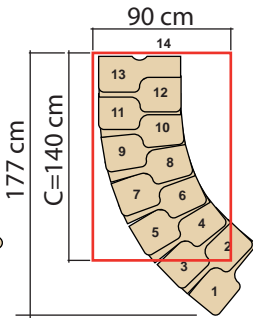
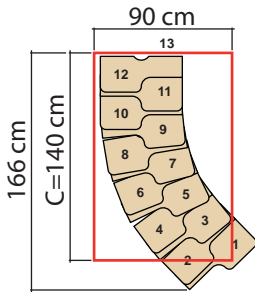
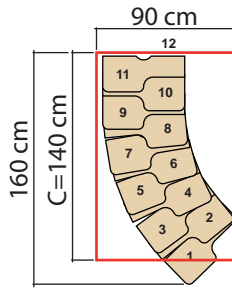
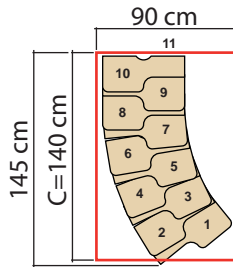

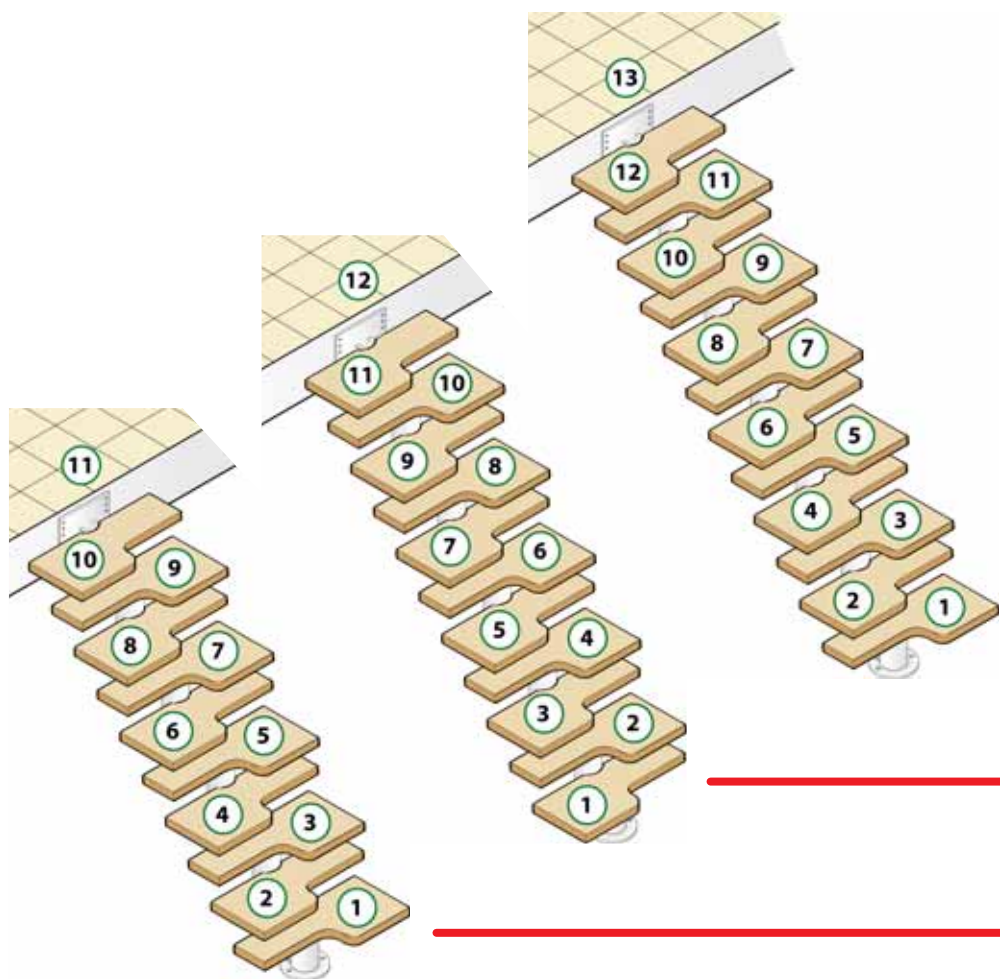

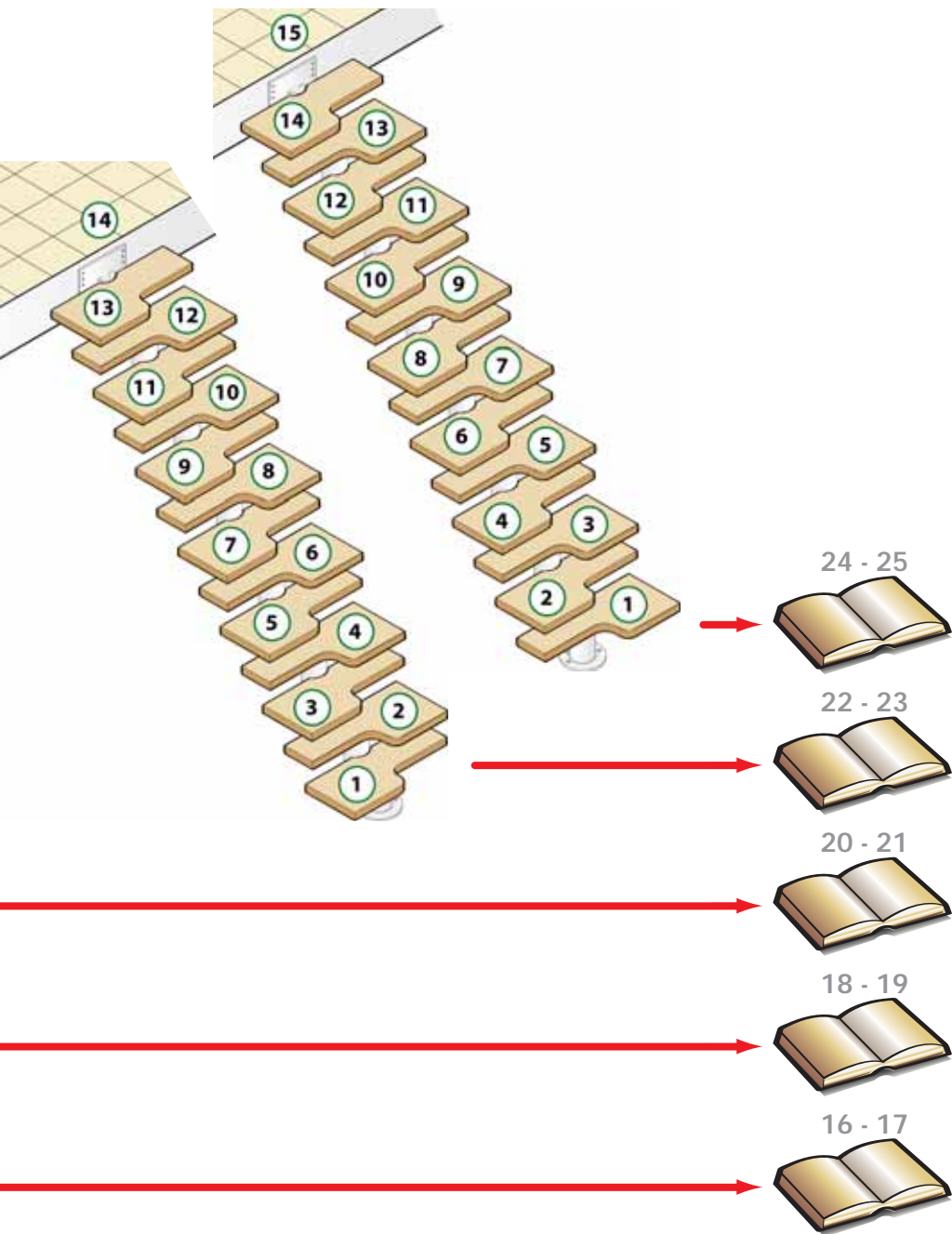

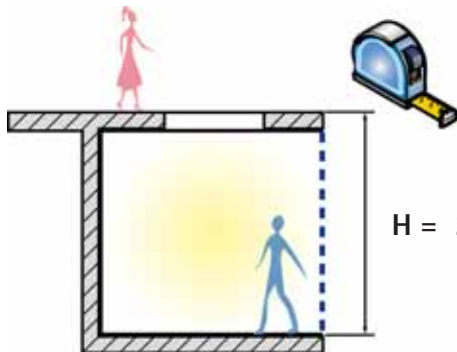

$H = 212 \div 257 \text{ cm}$

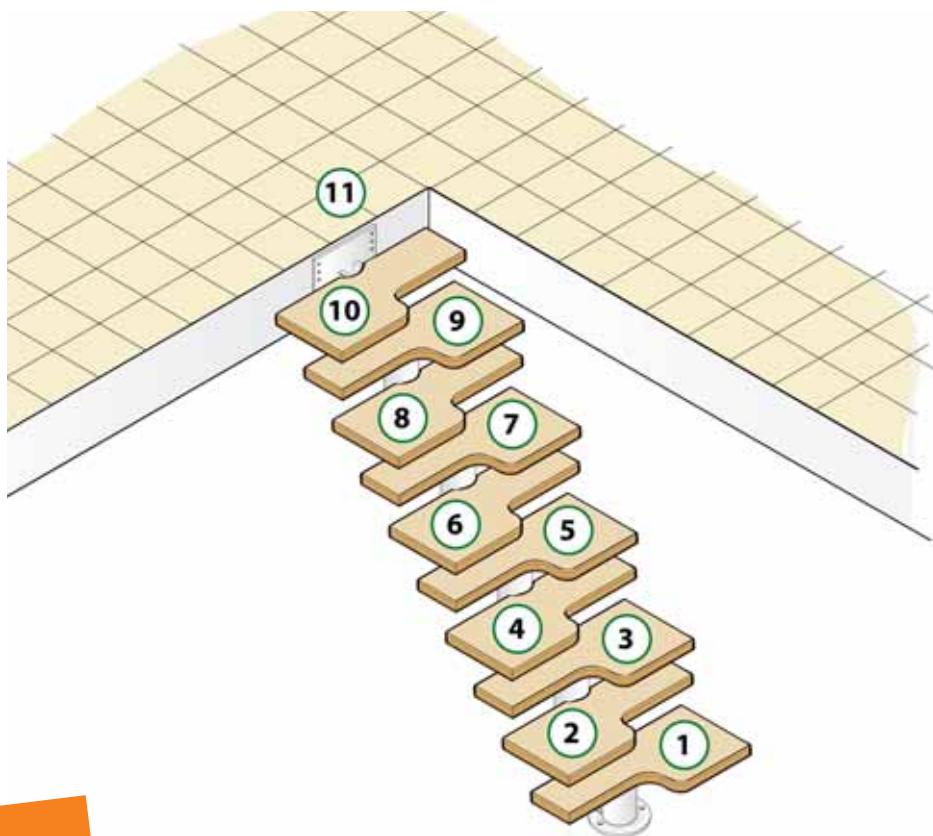

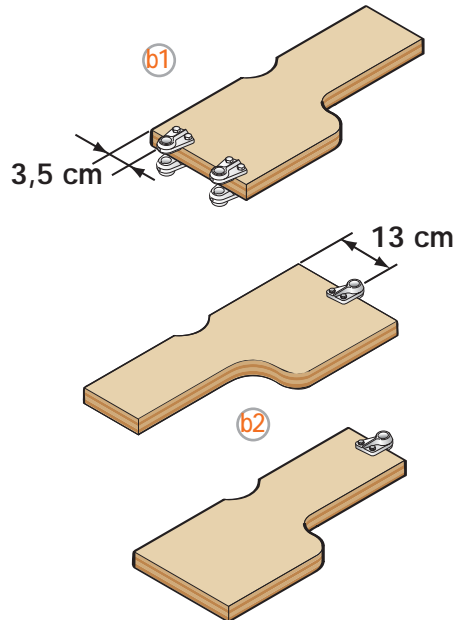
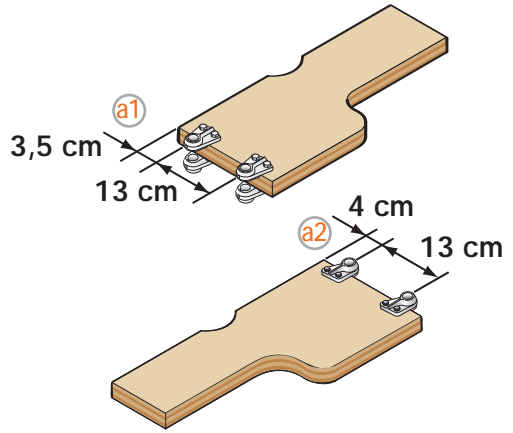
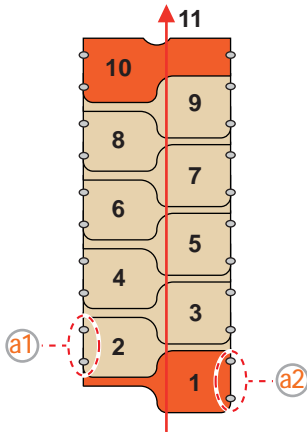

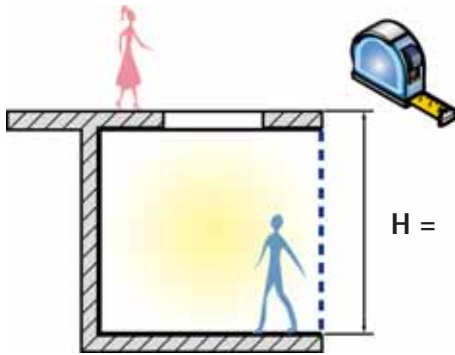

$H = 231 \div 280 \text{ cm}$

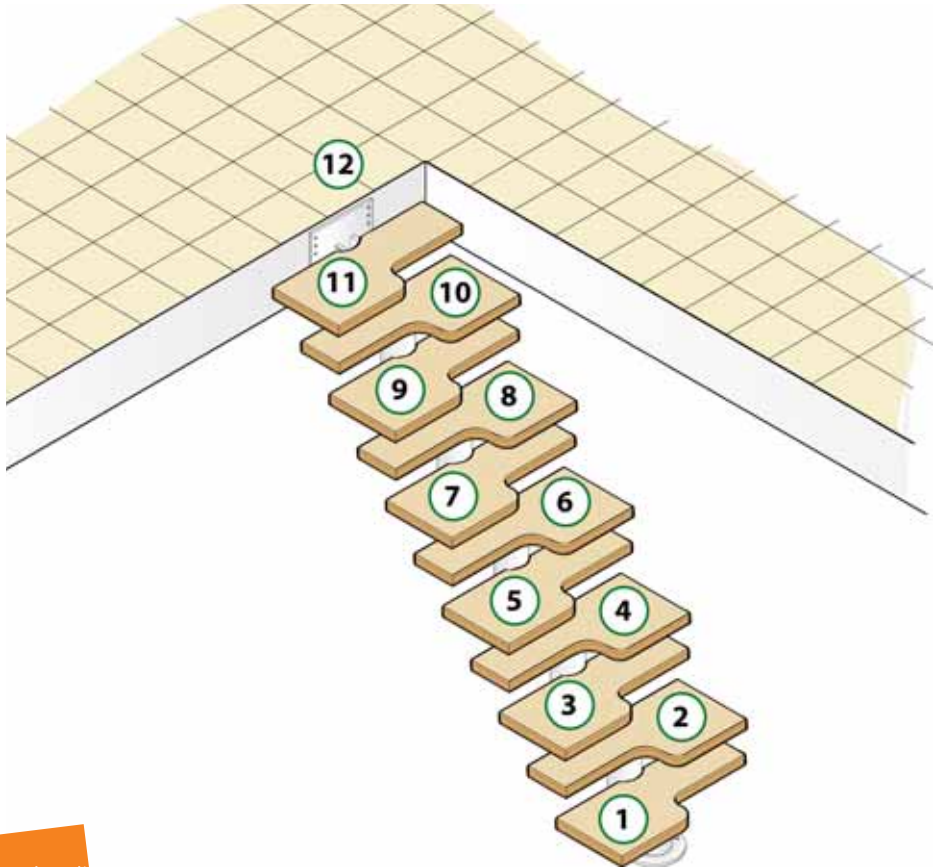

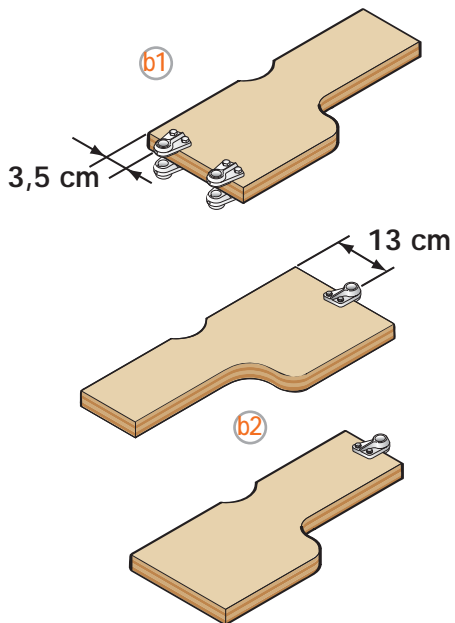
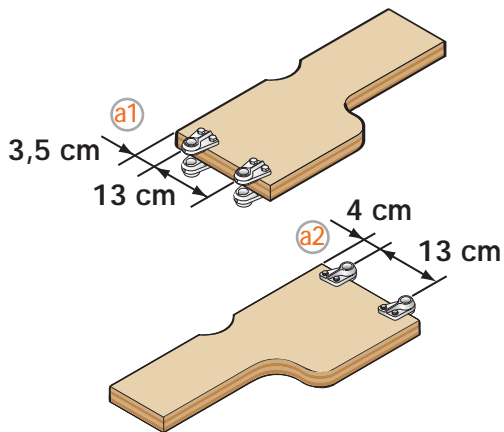
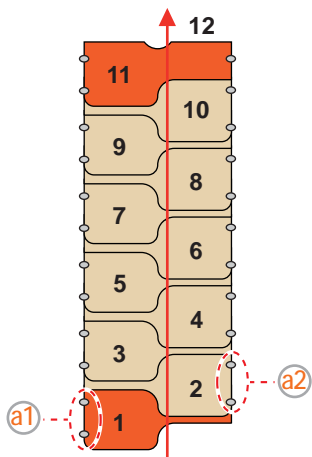

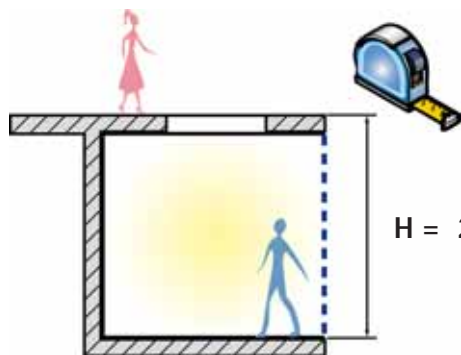

$H = 250 \div 304 \text{ cm}$

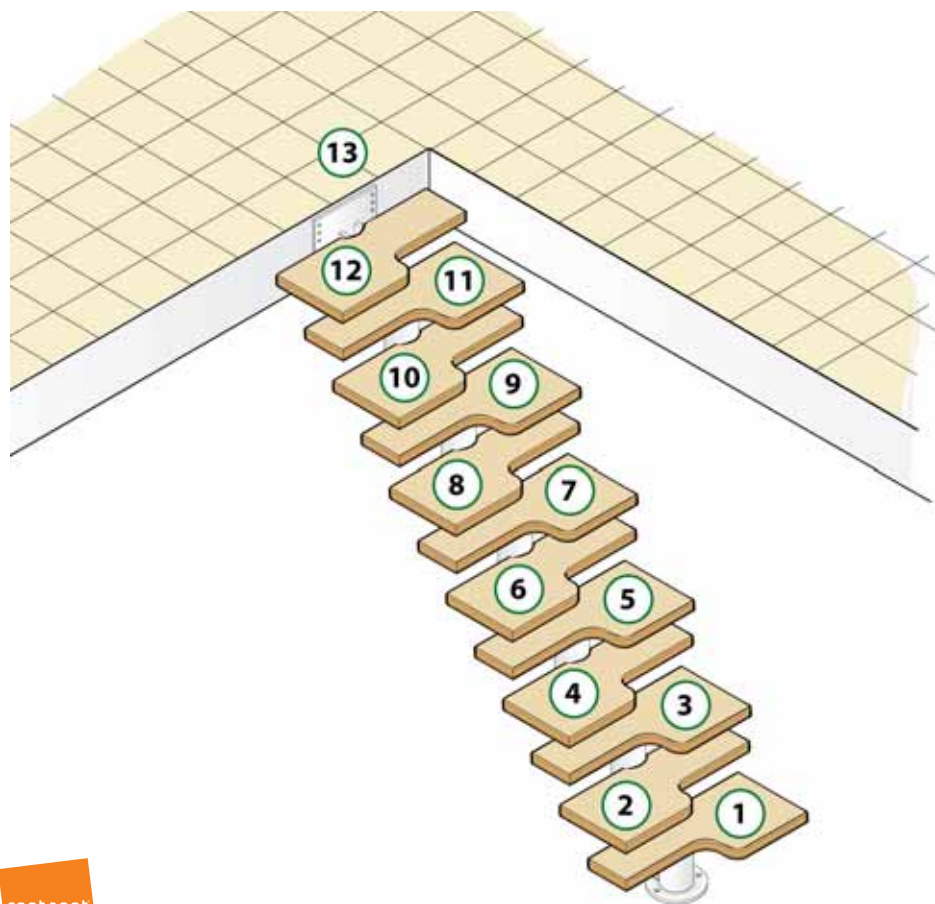

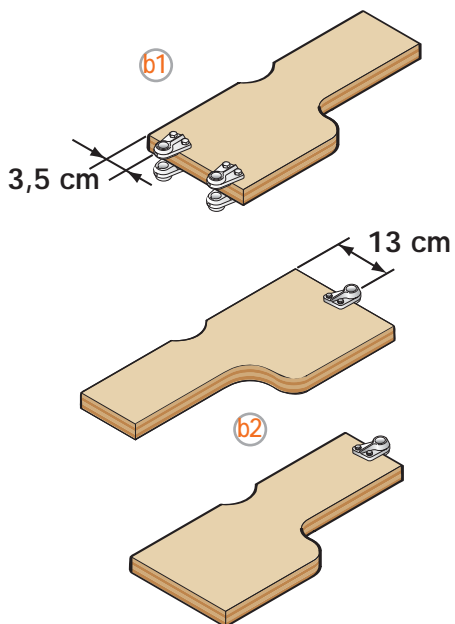
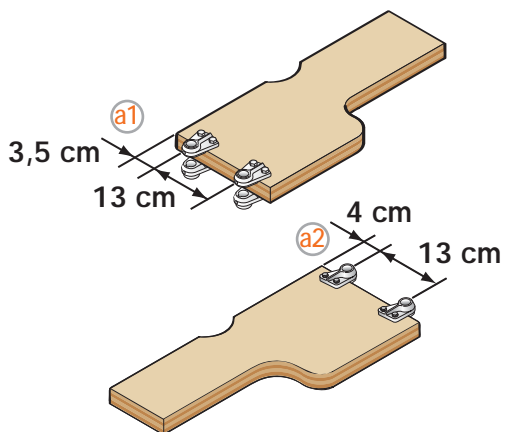
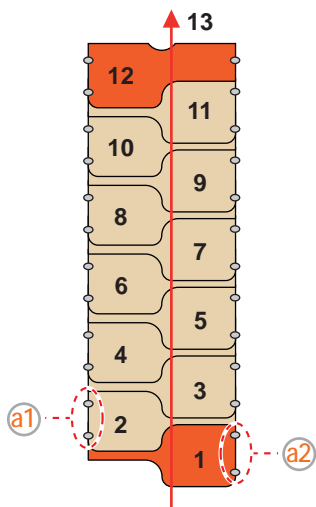

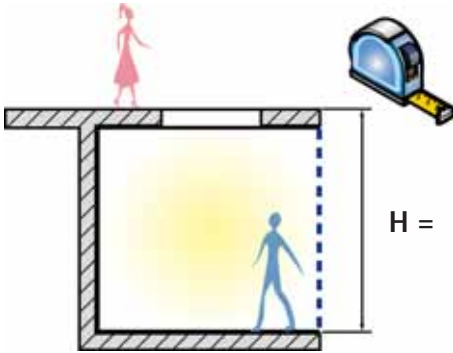

$H = 269 \div 327 \text{ cm}$

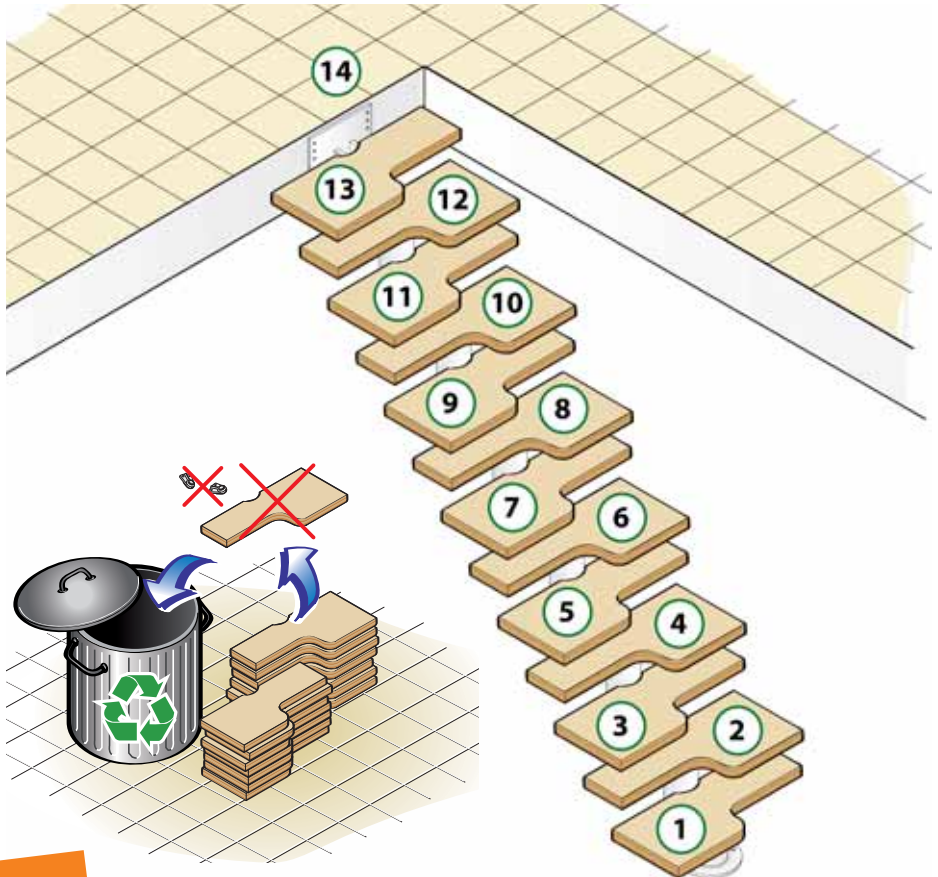

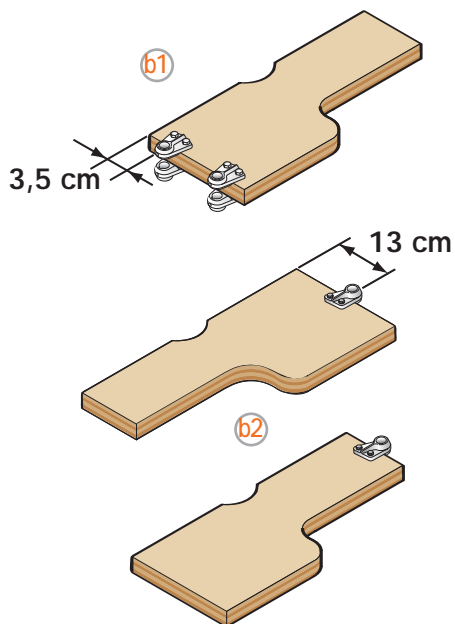
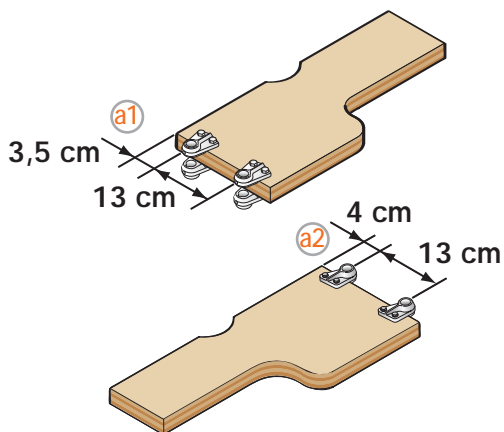
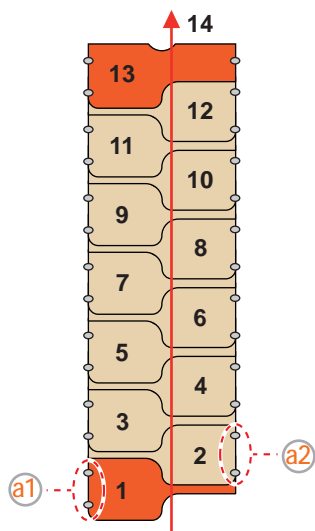

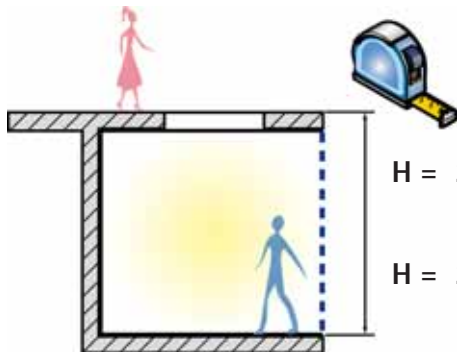

$$H = 269 \div 327 \text{ cm} \quad (14)$$

$$H = 288 \div 351 \text{ cm} \quad (15)$$

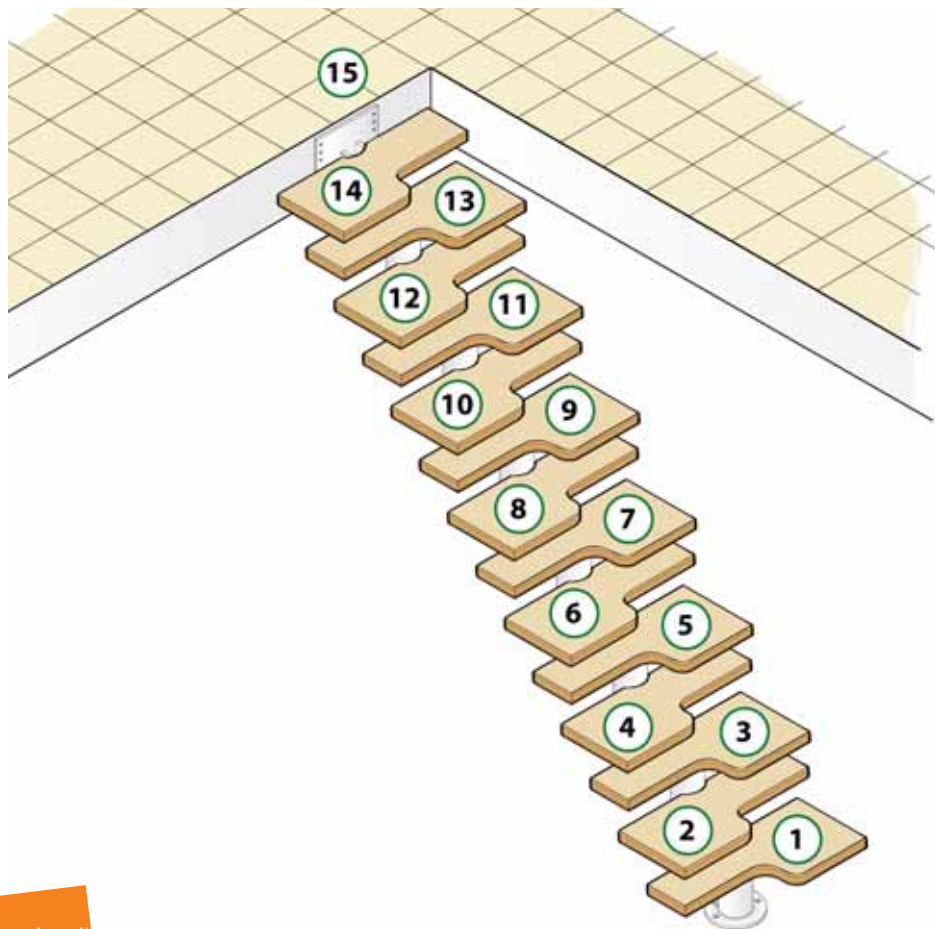

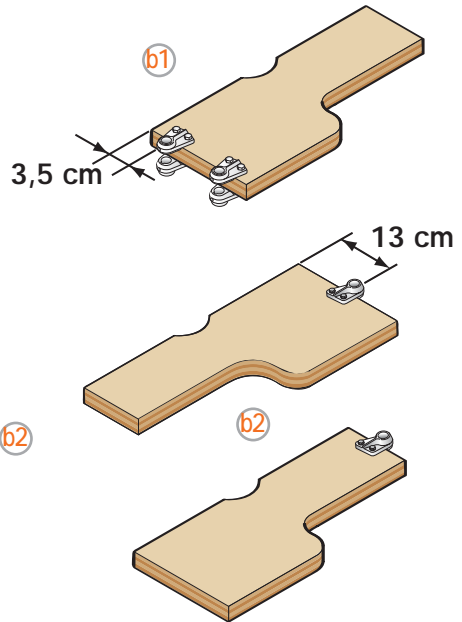
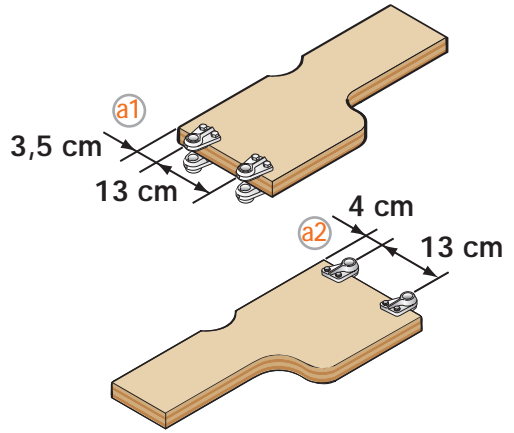
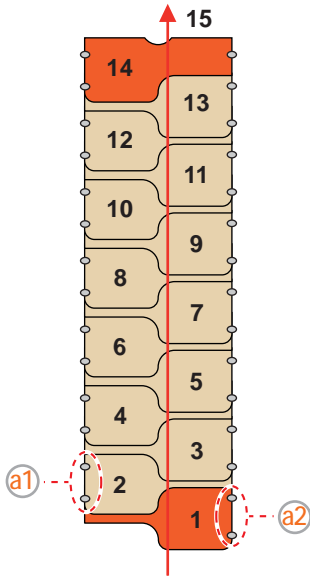

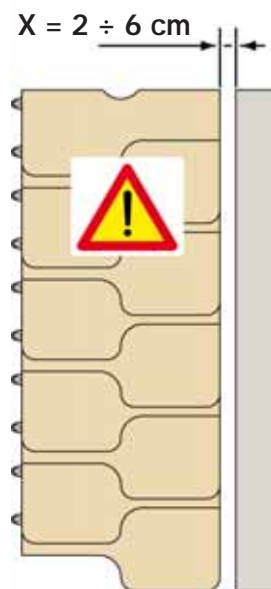
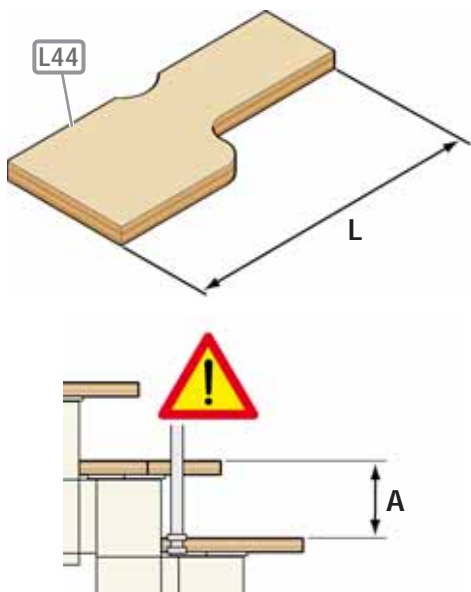
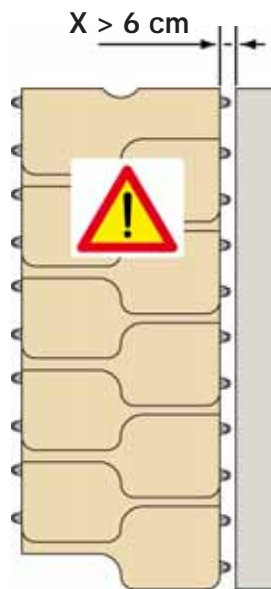
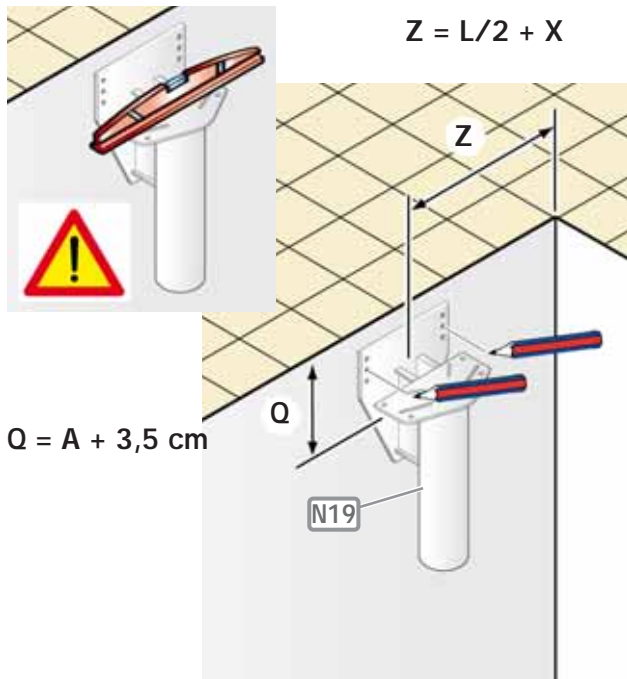

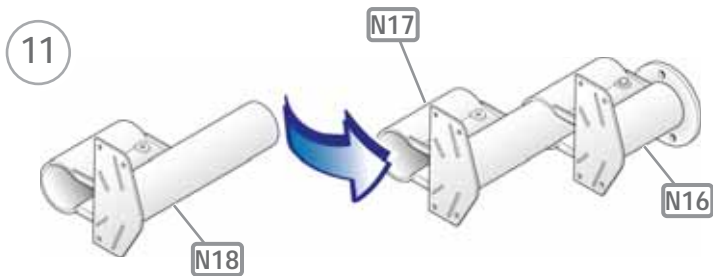
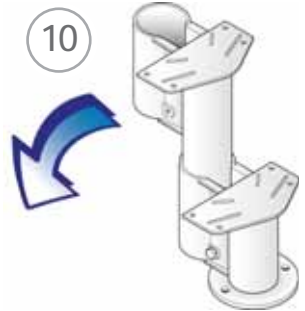
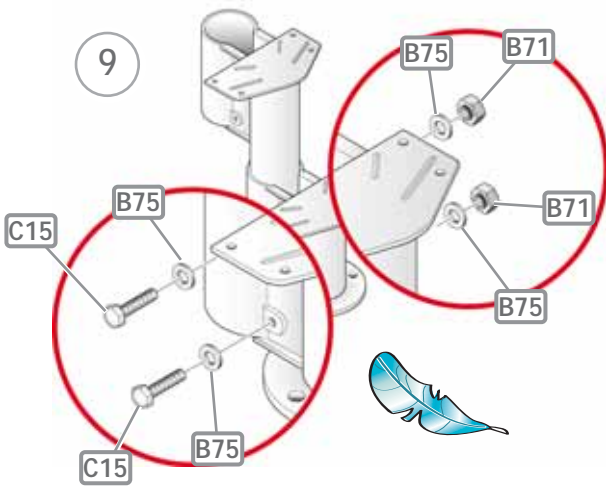
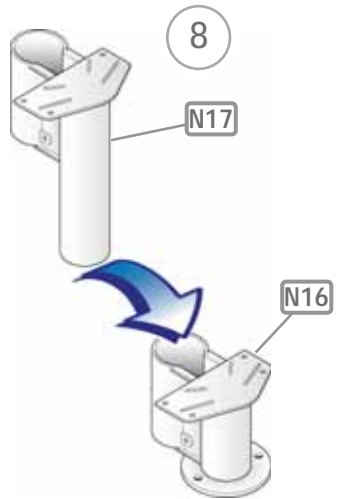
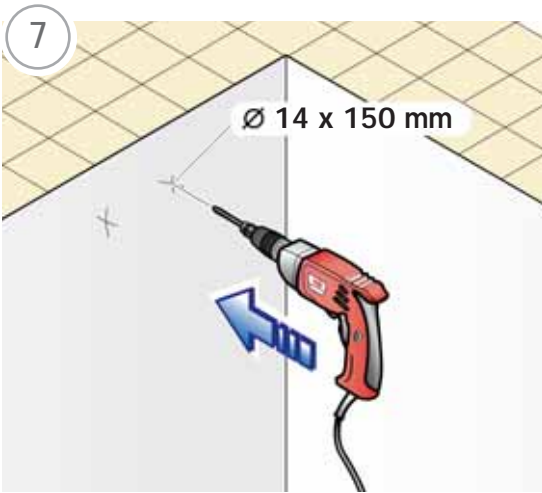

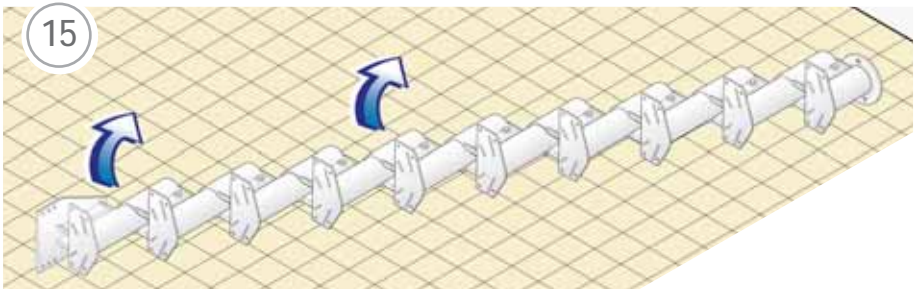
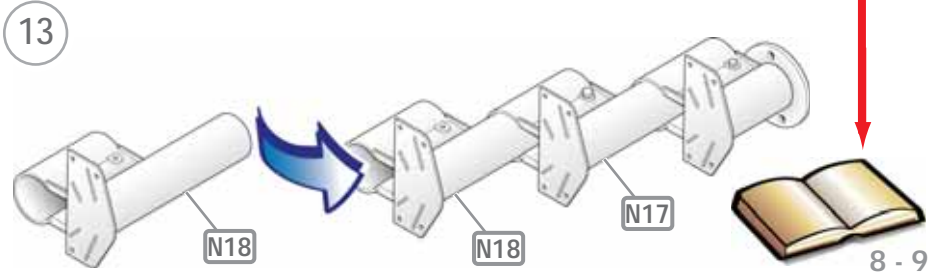
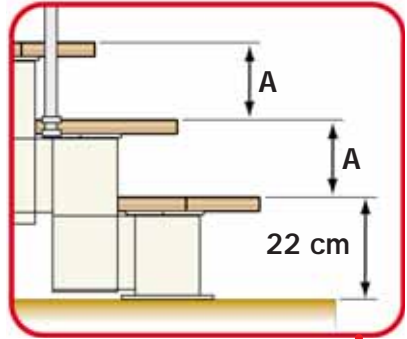
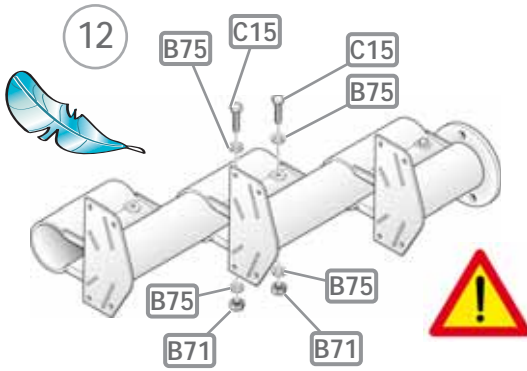

16

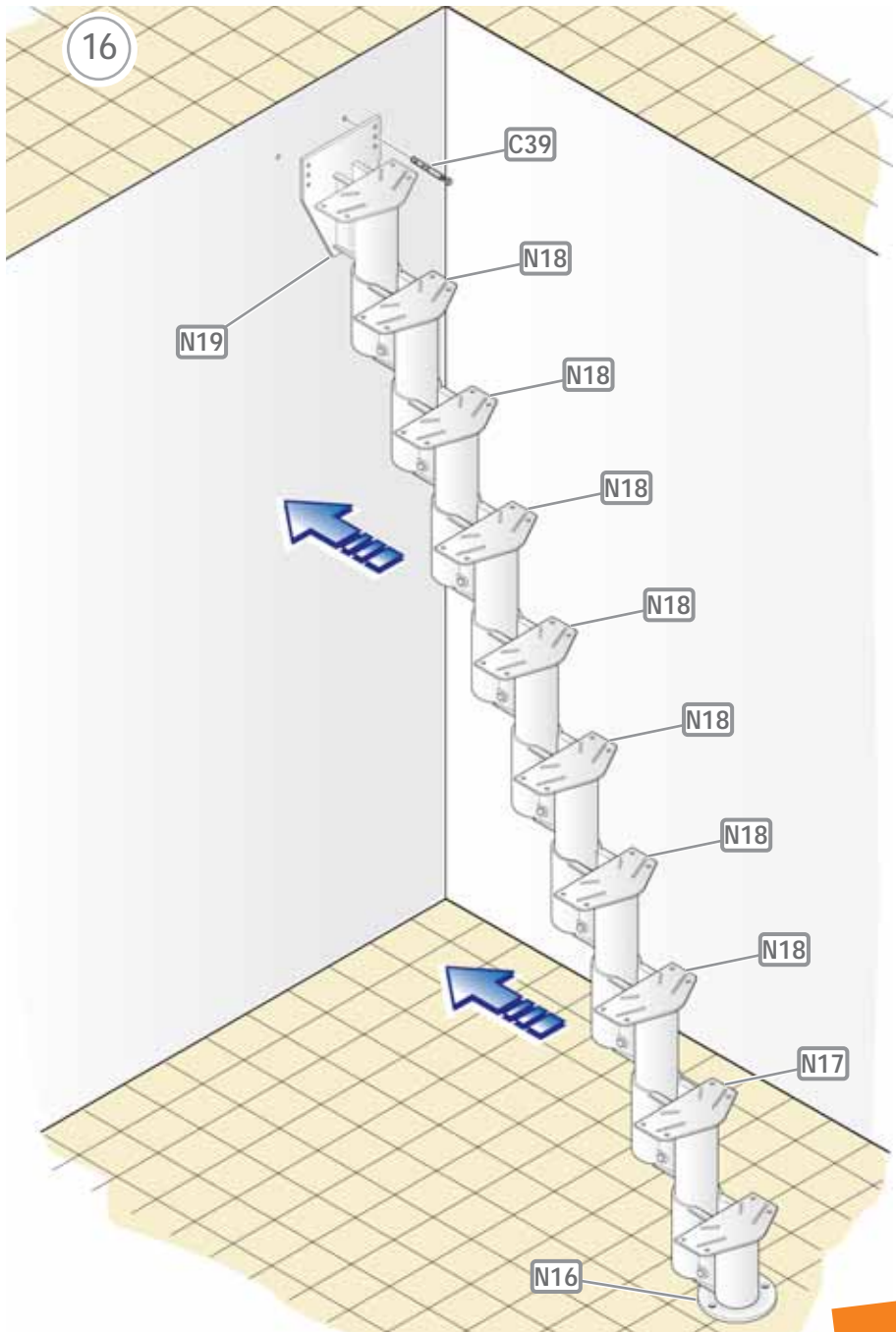

17

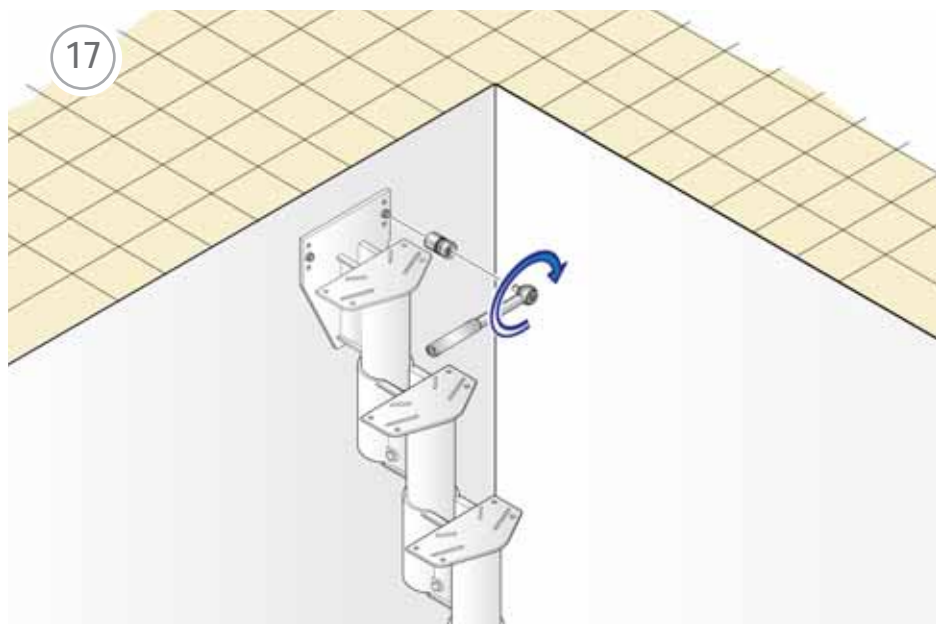

18

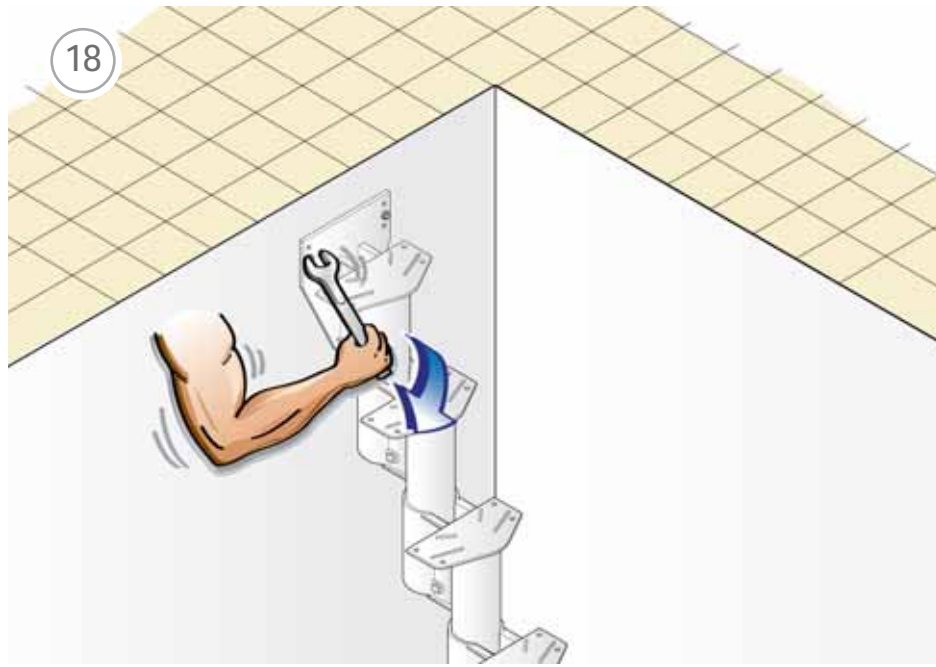

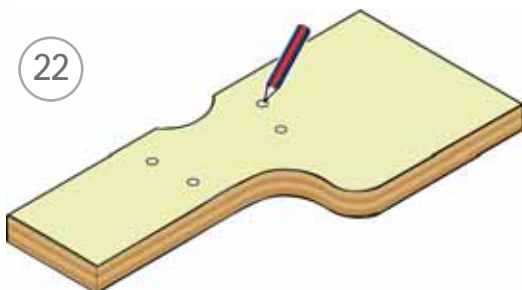
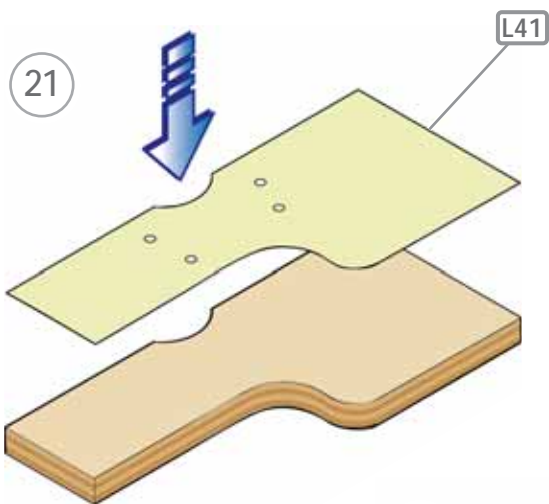
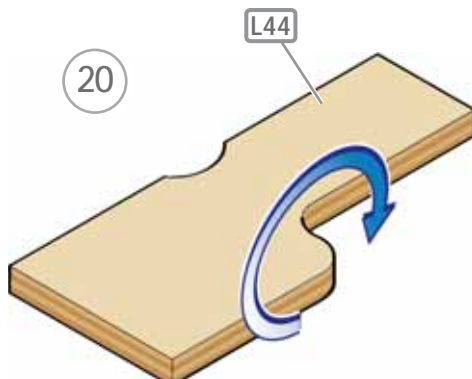
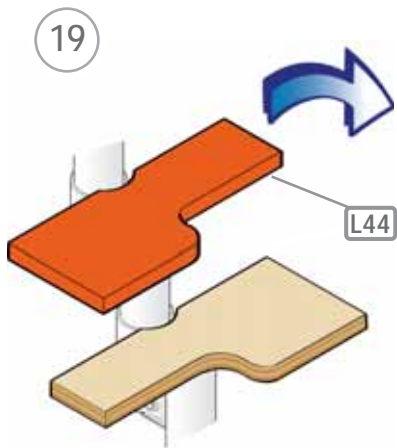

23

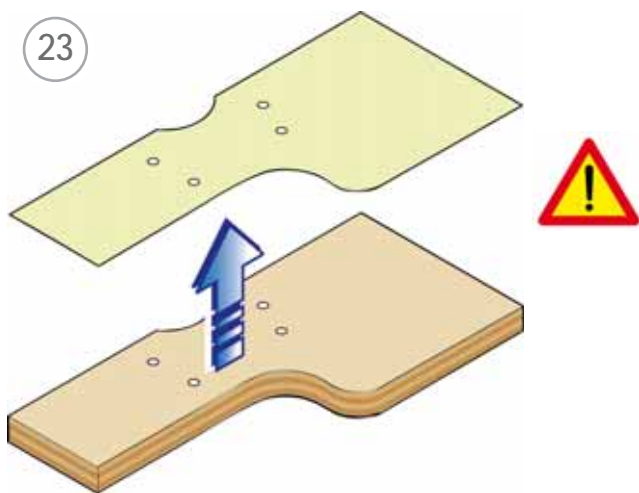

24

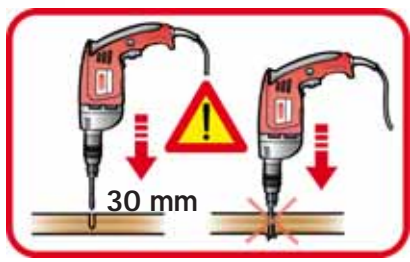
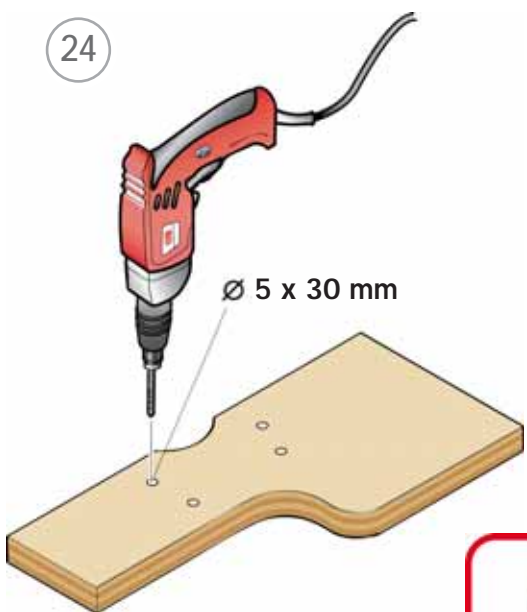

25

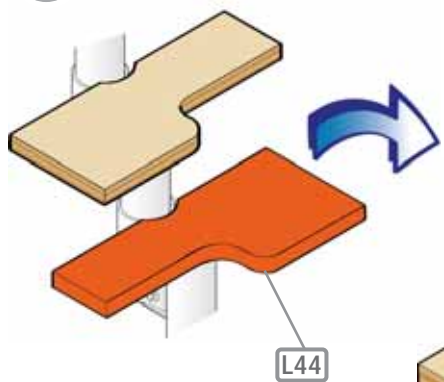

26

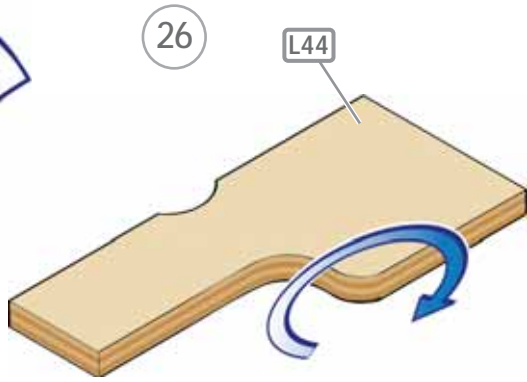

27

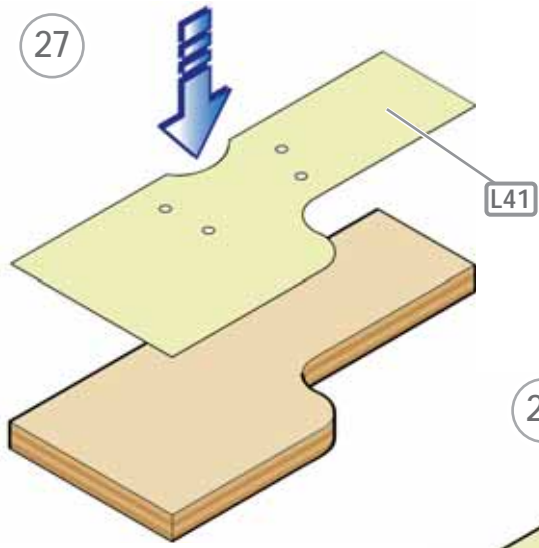

28

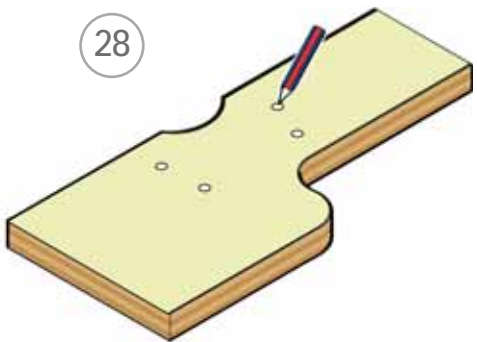

29

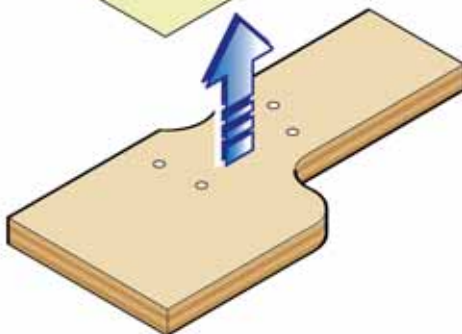
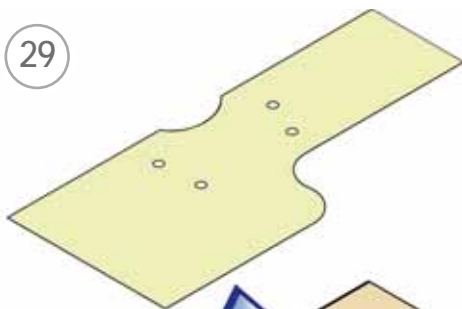

30

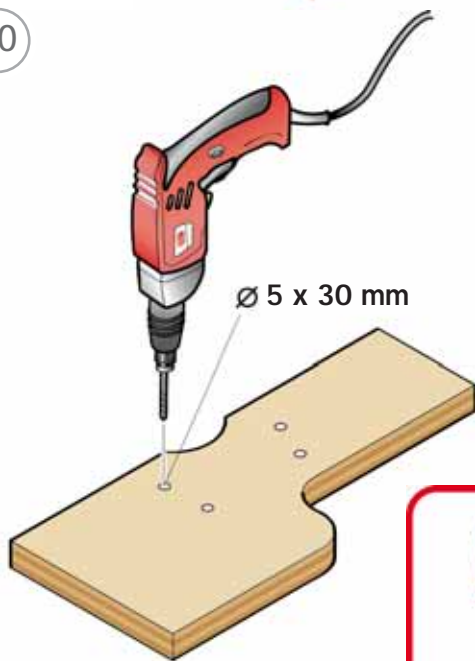

Ø 5 x 30 mm

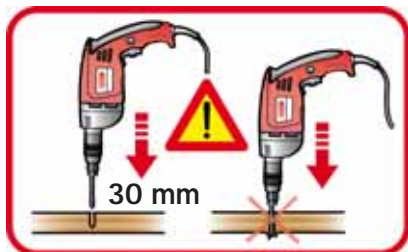

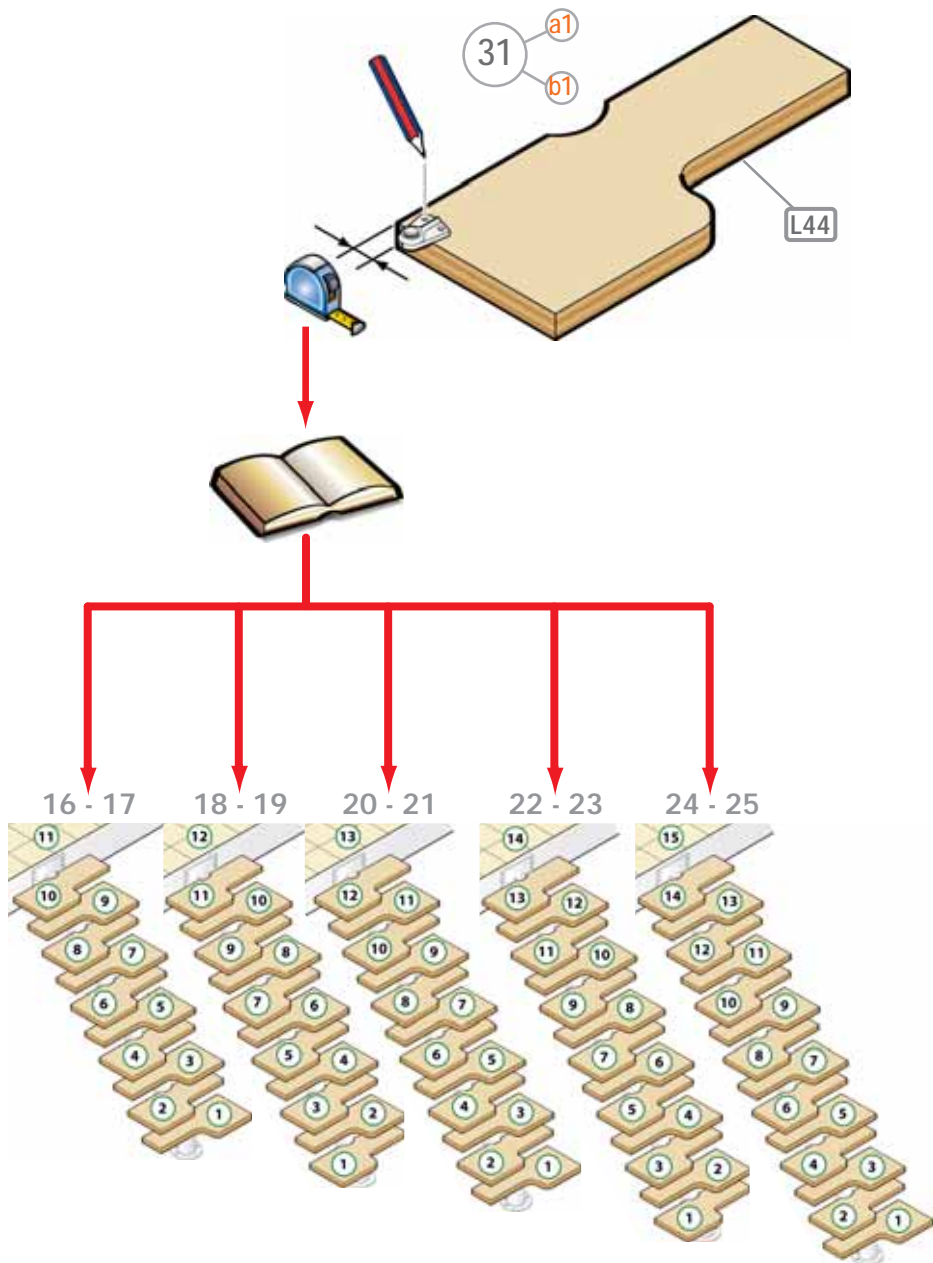

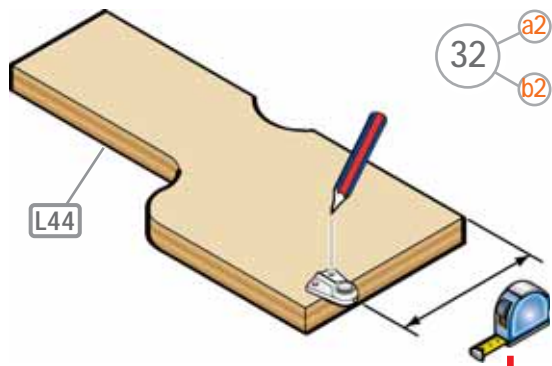

16 - 17

18 - 19

20 - 21

22 - 23

24 - 25

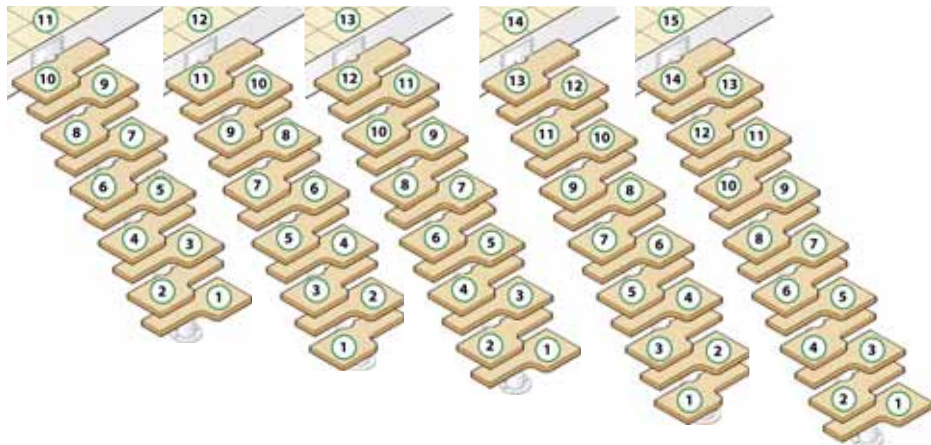

33

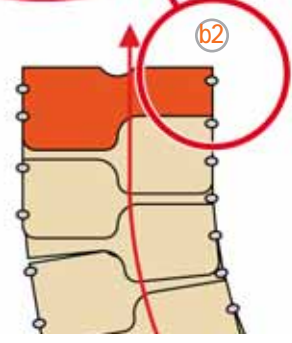
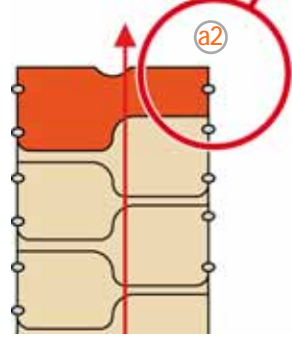
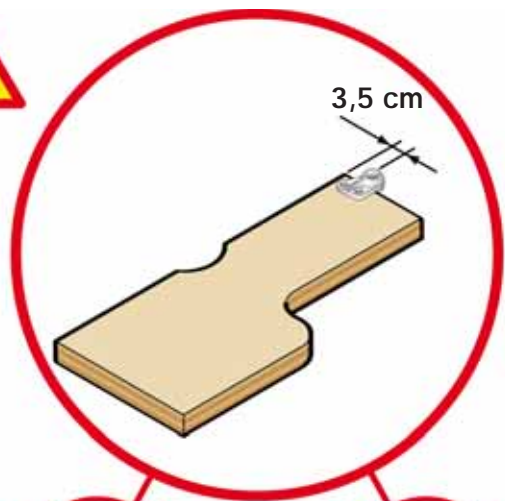

34

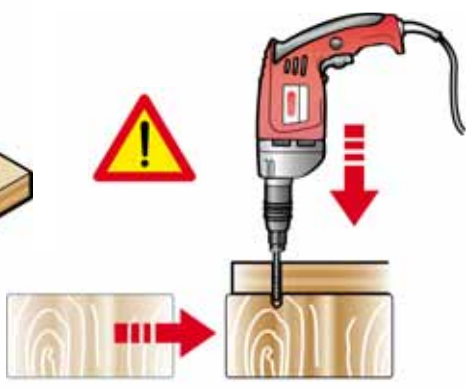
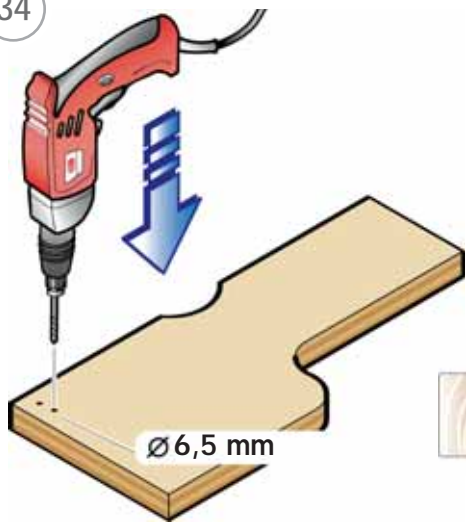

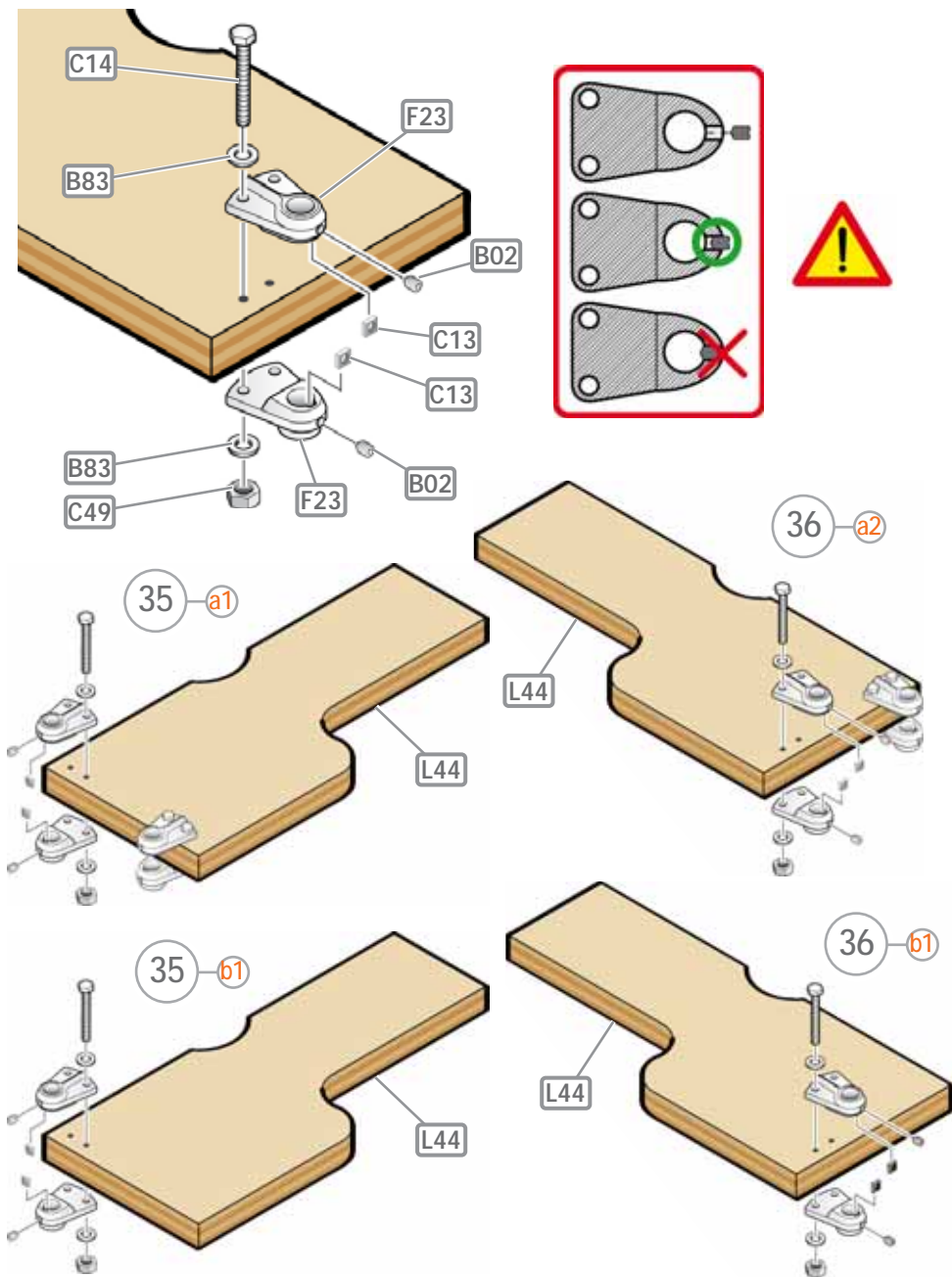

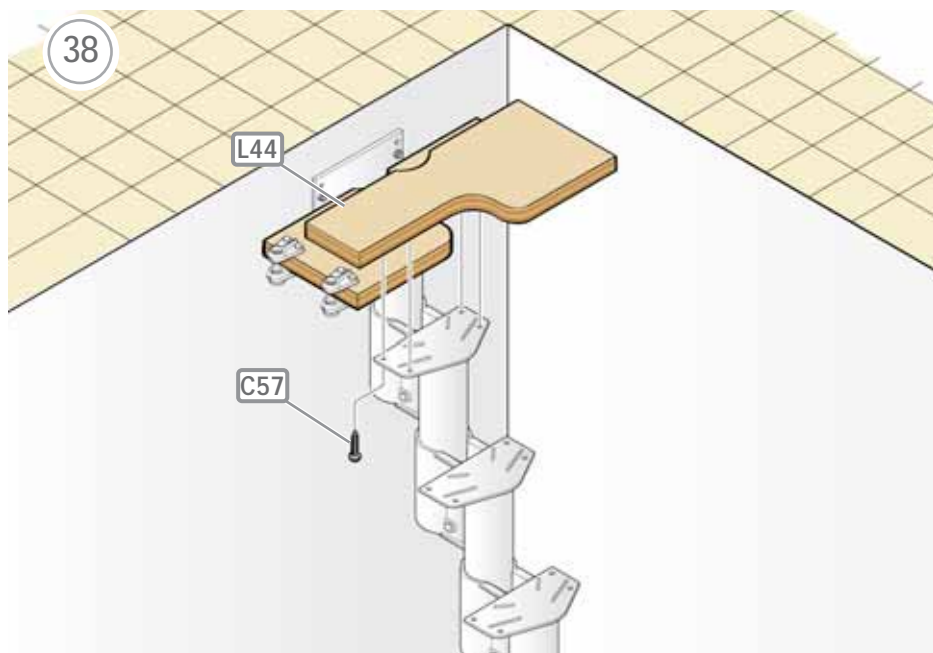
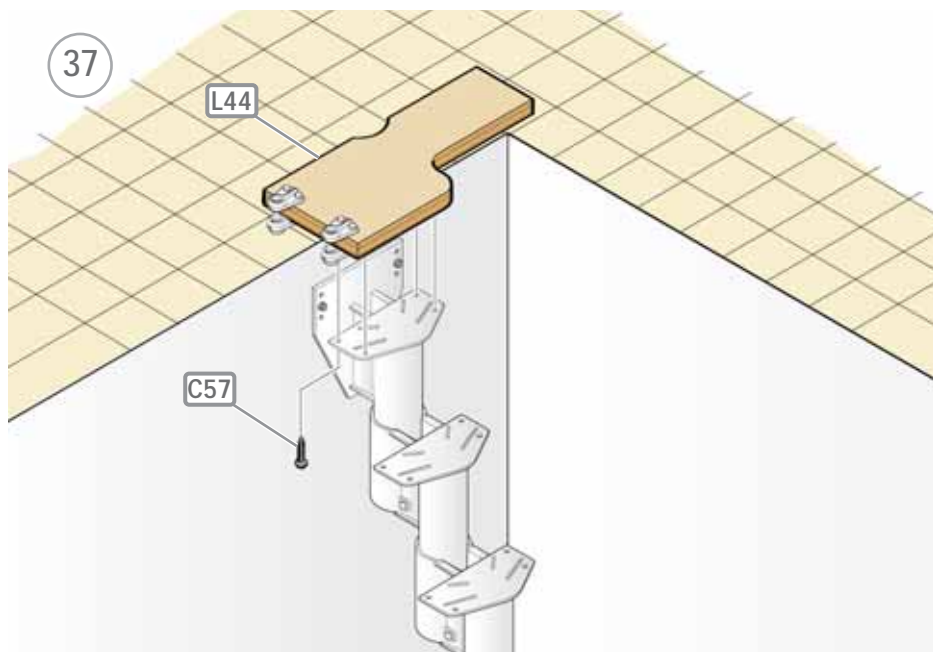

a1	a2	b1	b2
D = 98 cm 		D = 98 cm 	
	D = 88 cm 		D = 92 cm

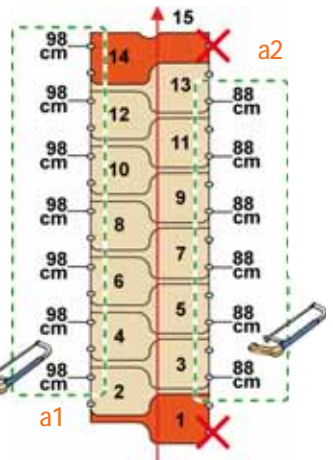
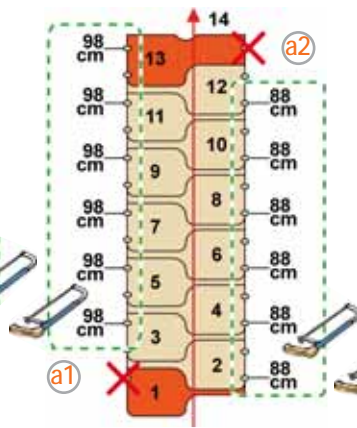
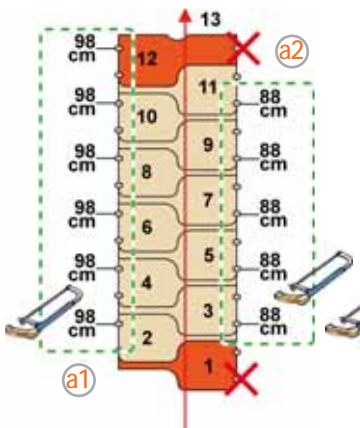
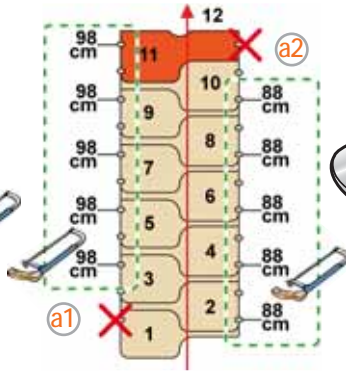
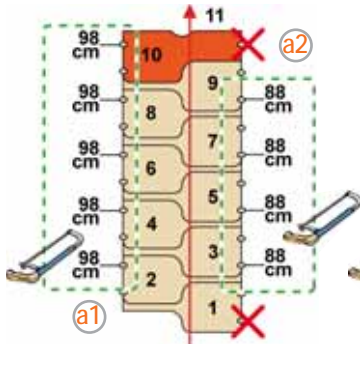
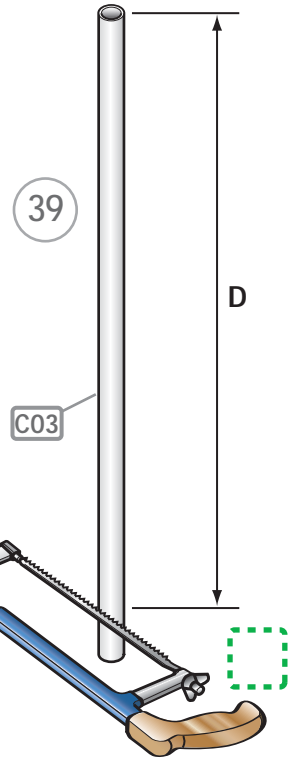

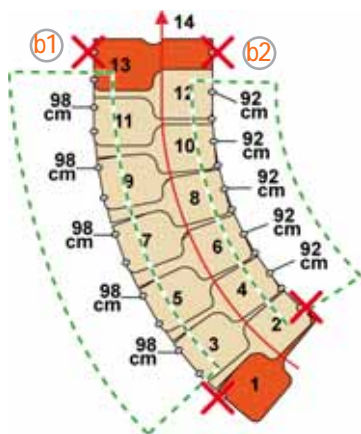
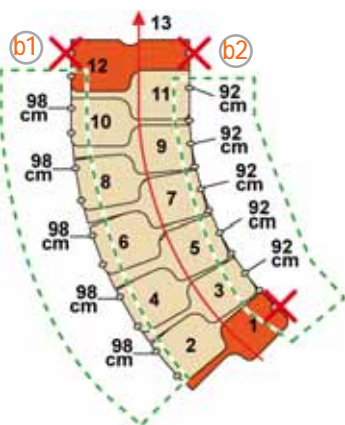
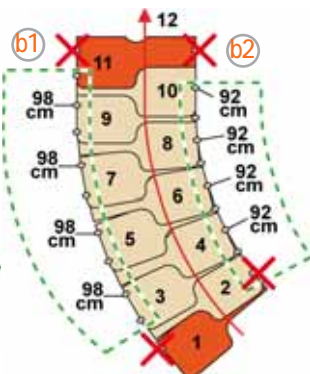
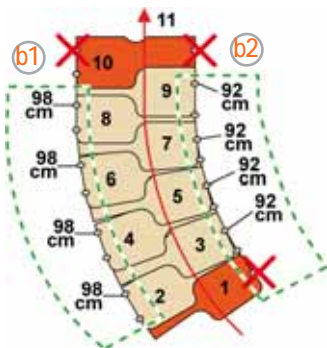
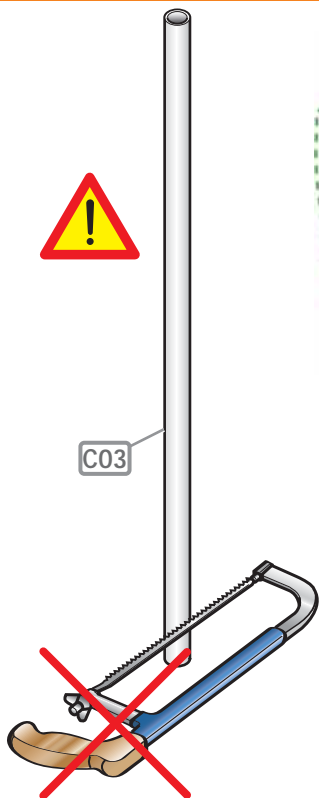

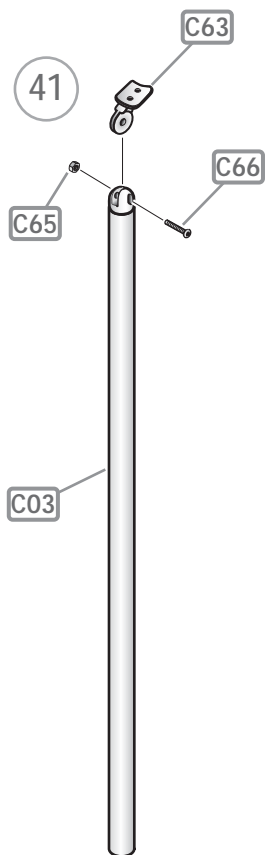
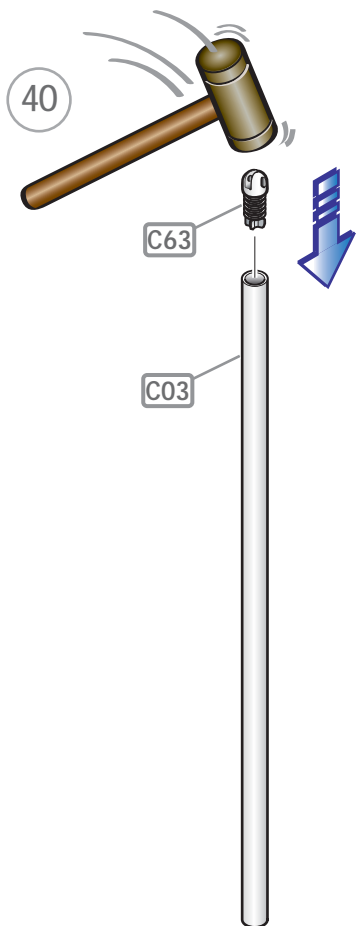

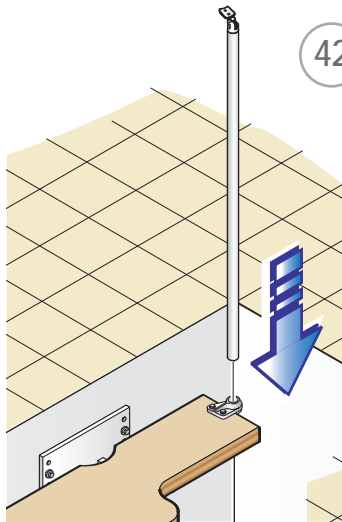
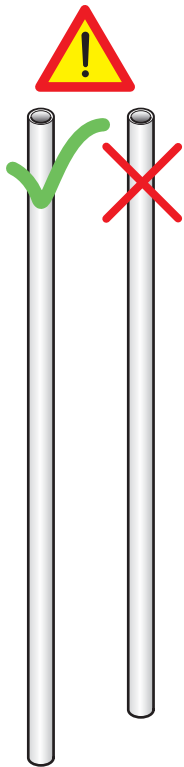

42 b

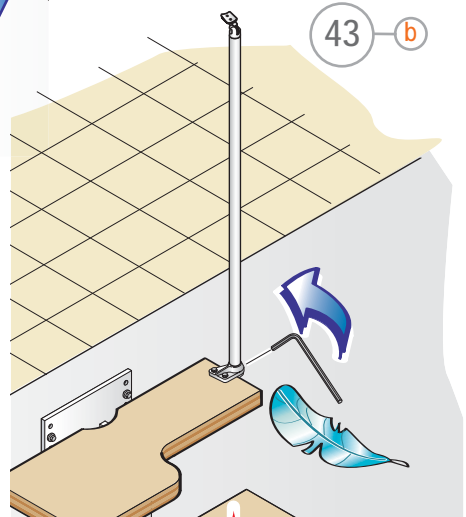

43 b

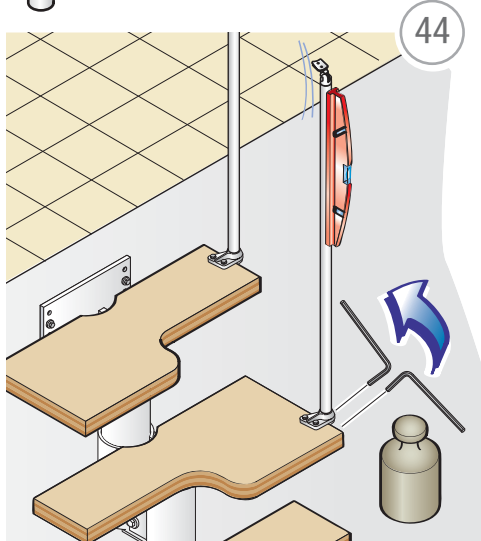

44

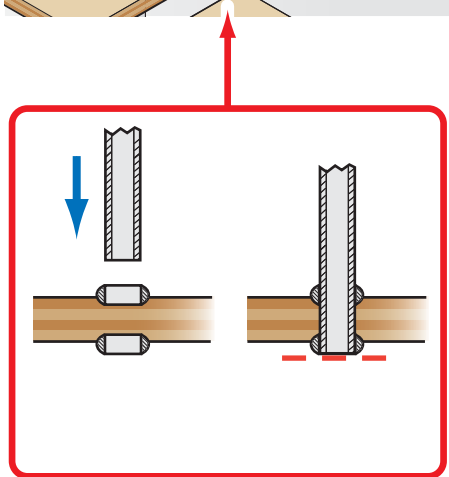

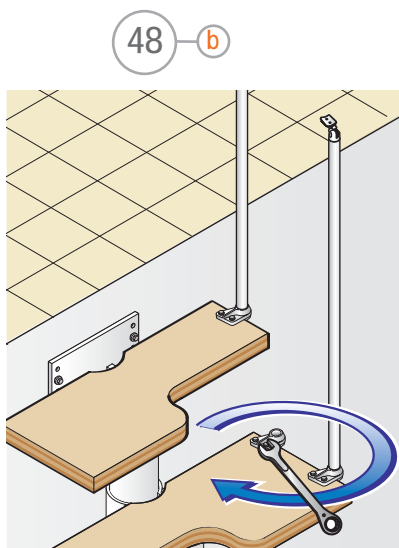
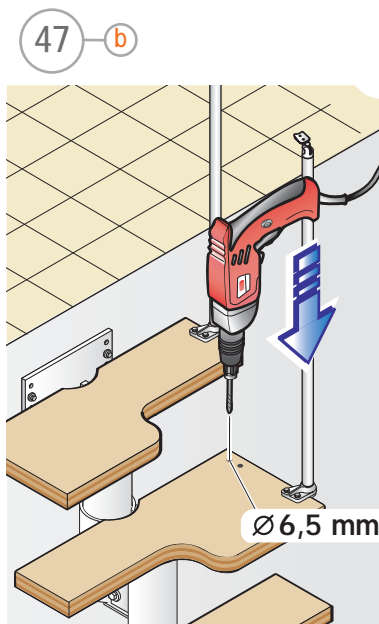
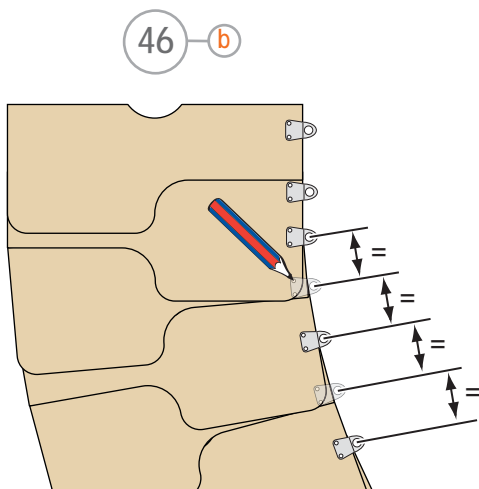
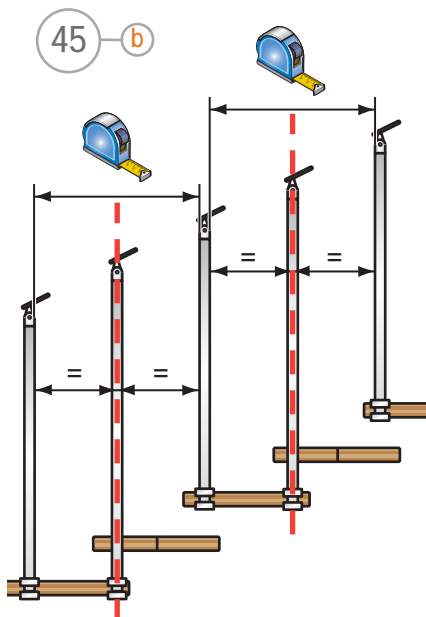

49

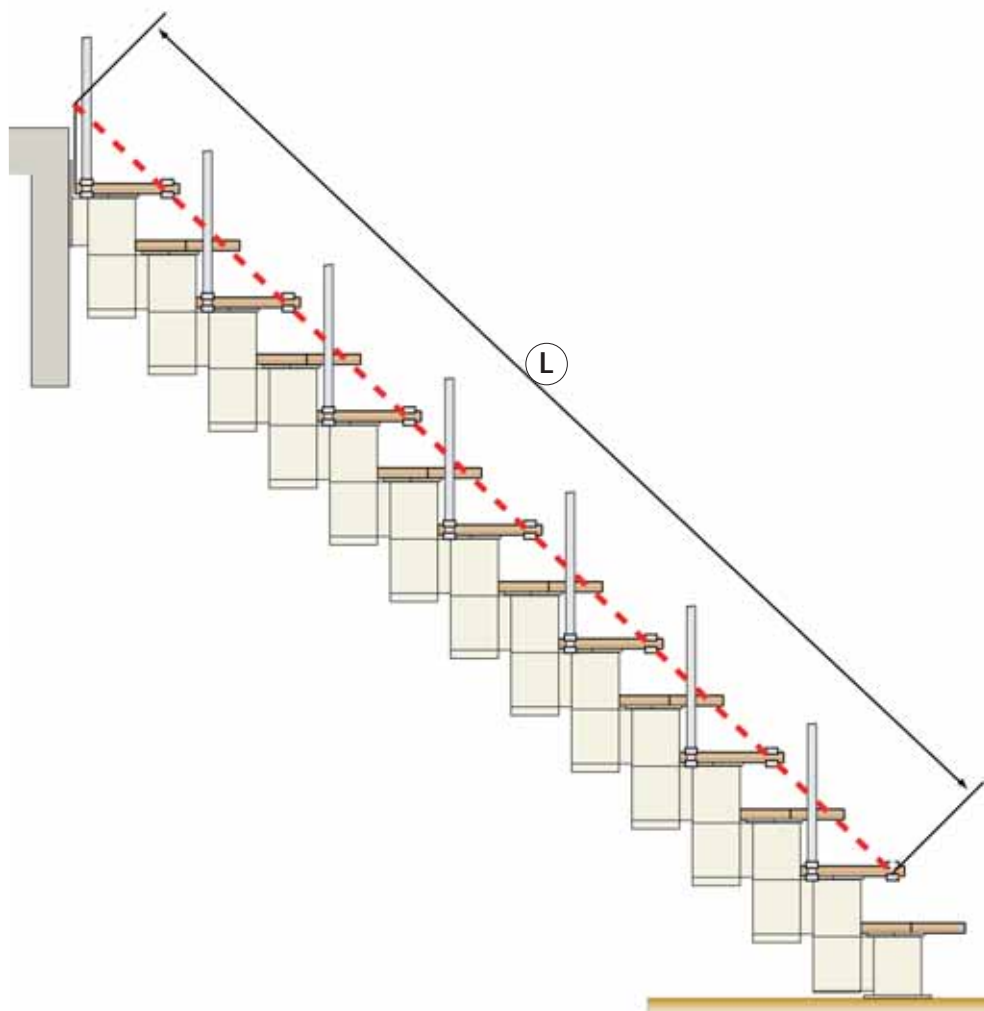

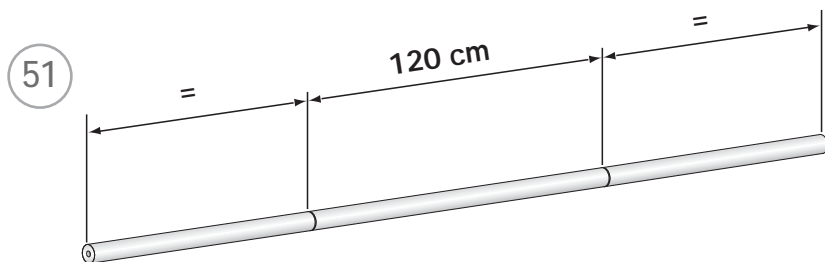
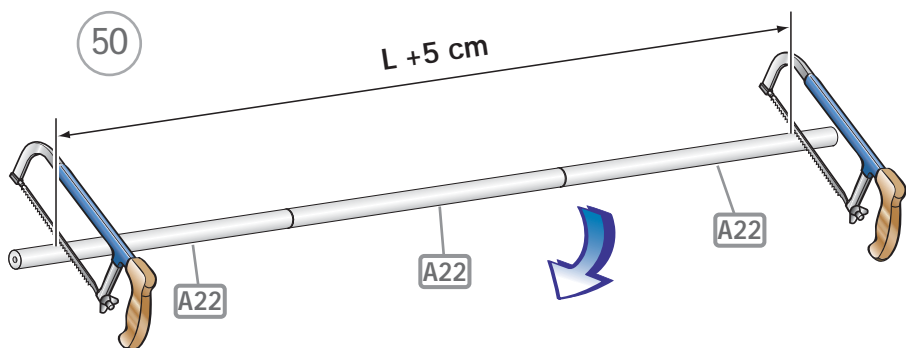
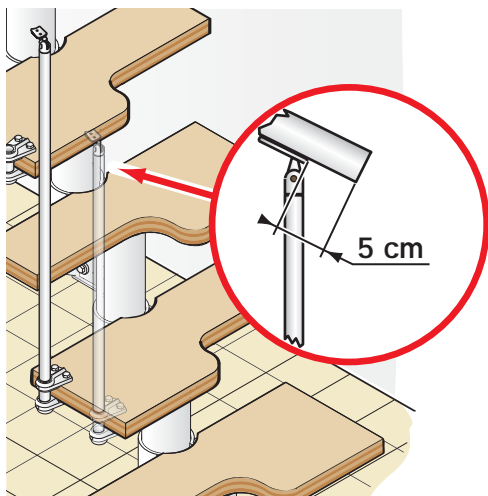

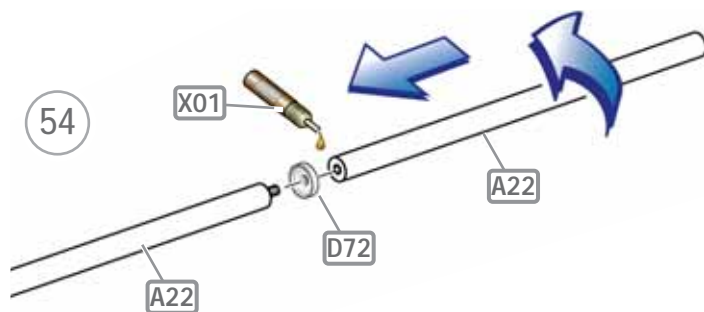
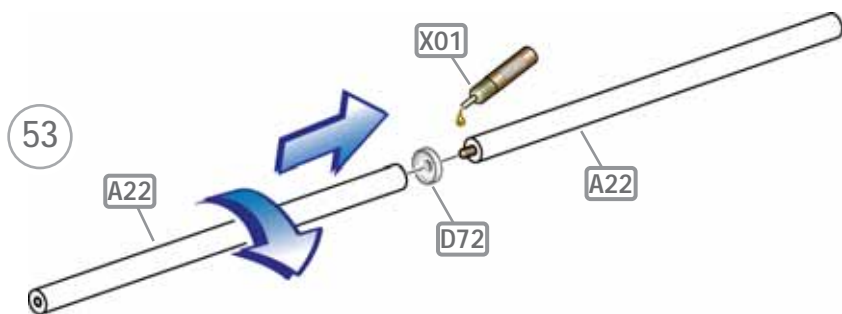
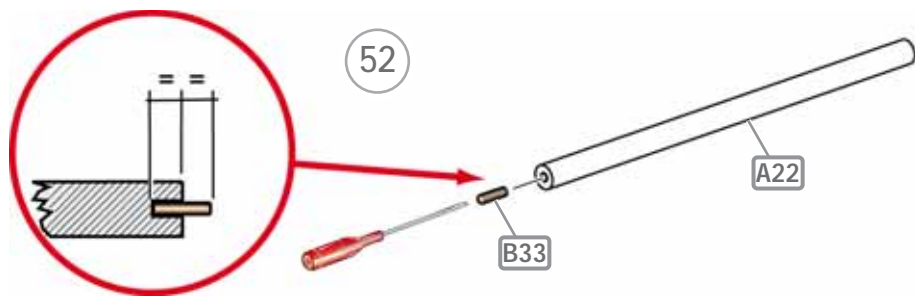

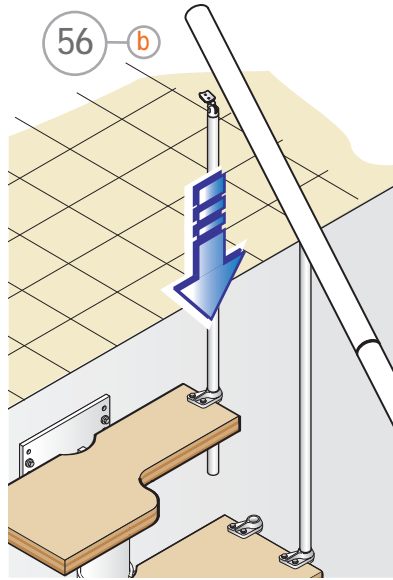
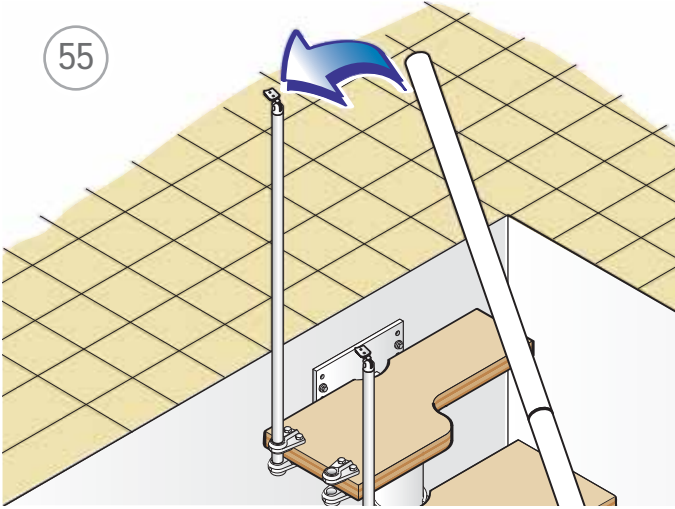

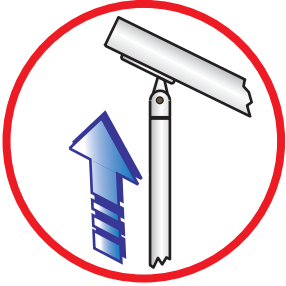

57 b

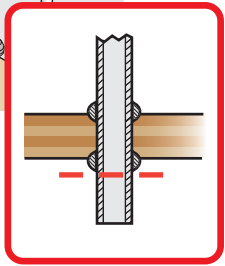
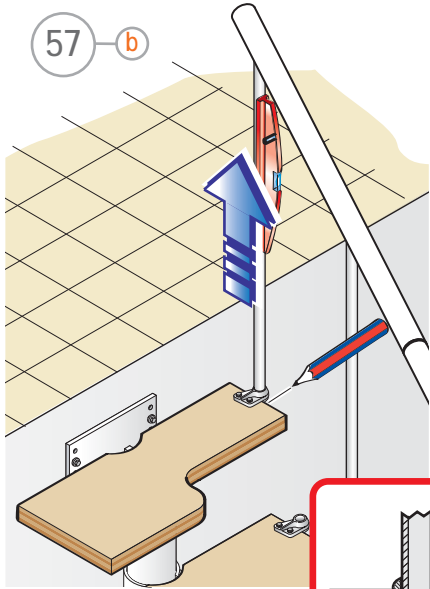

59 b

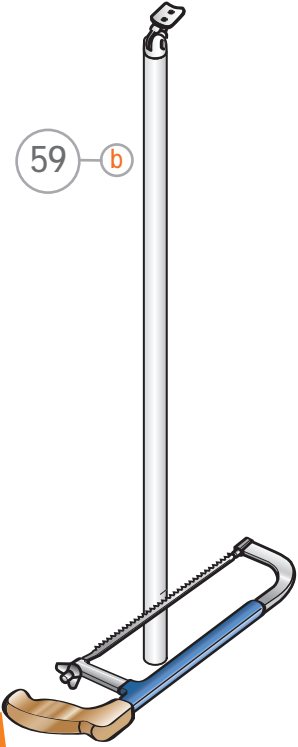

58 b

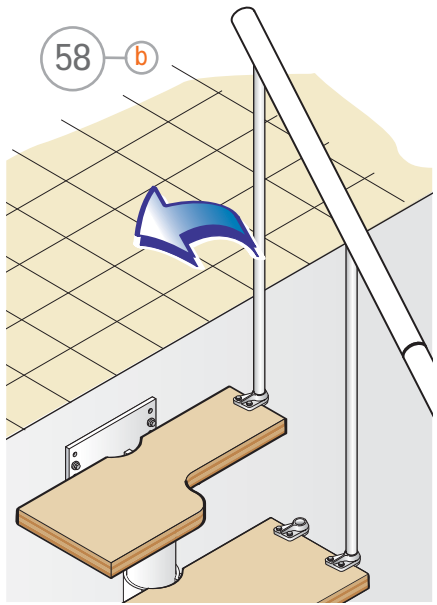

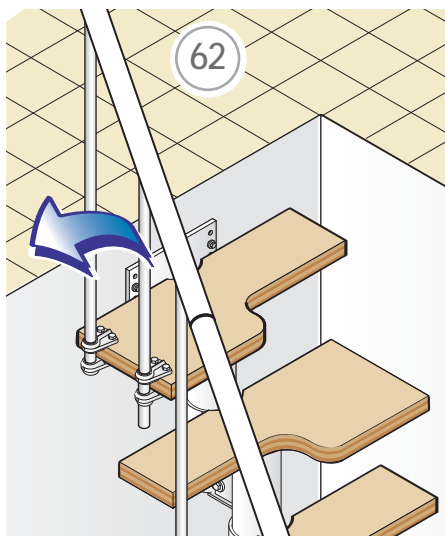
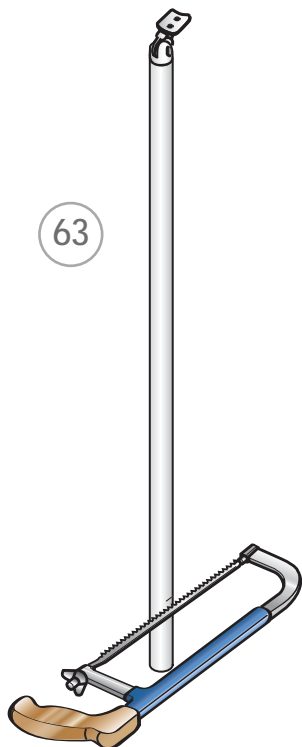
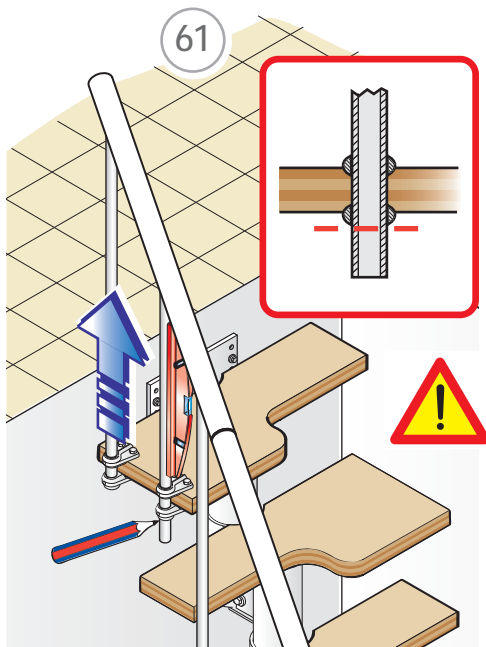
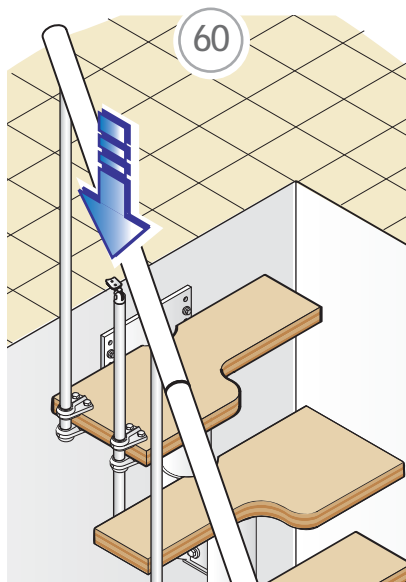

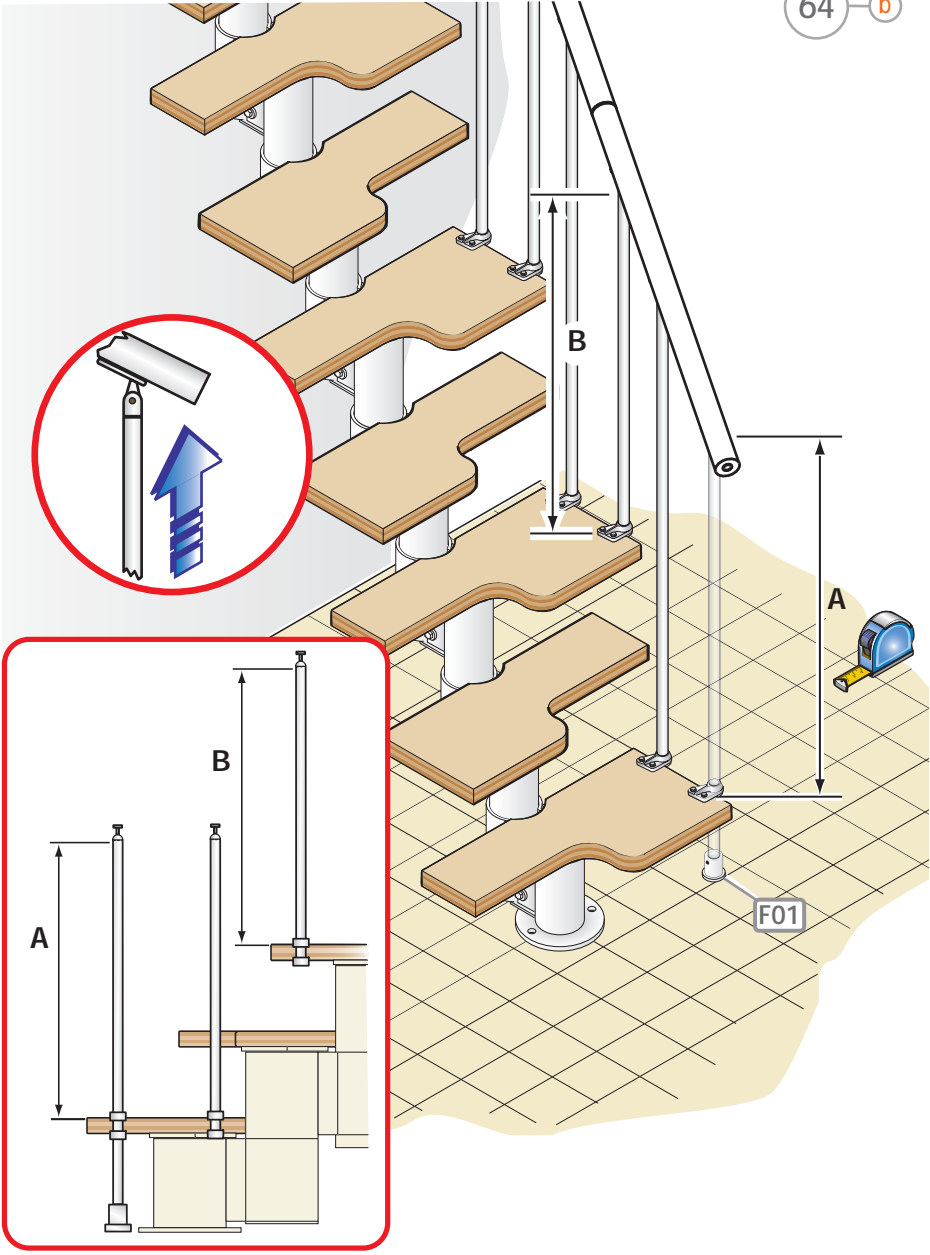

65 b

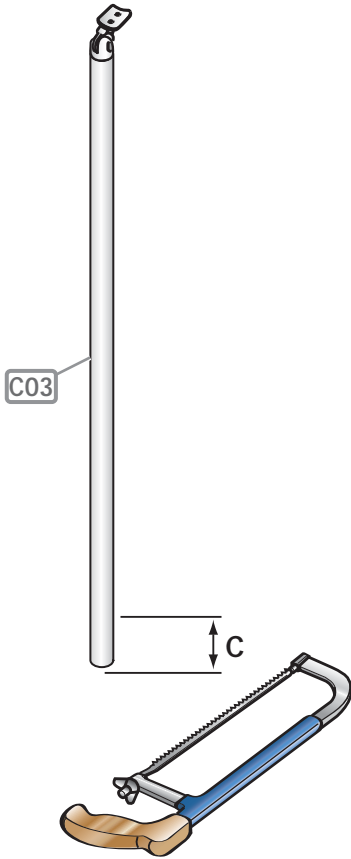

$$C = A - B$$

66 b

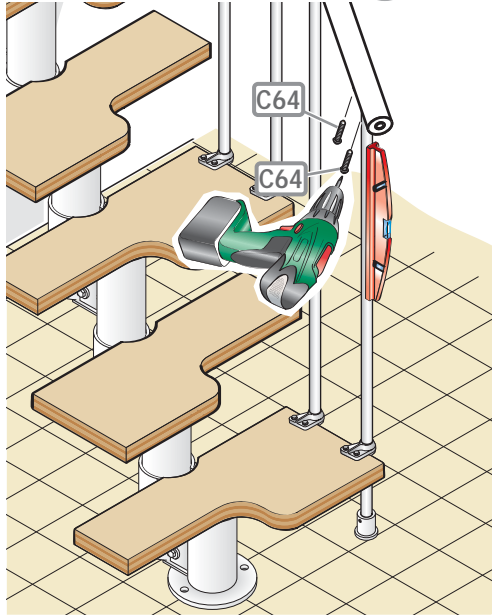

67

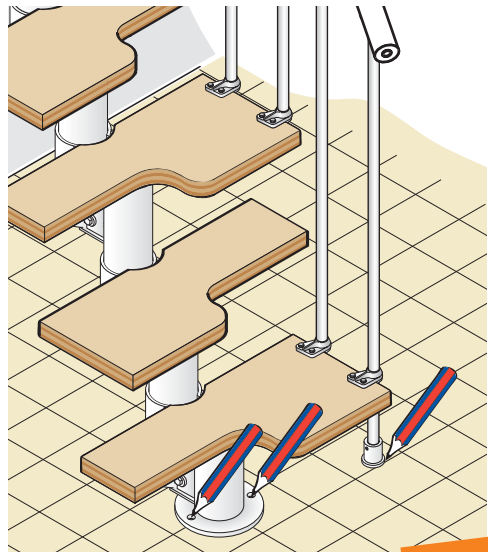

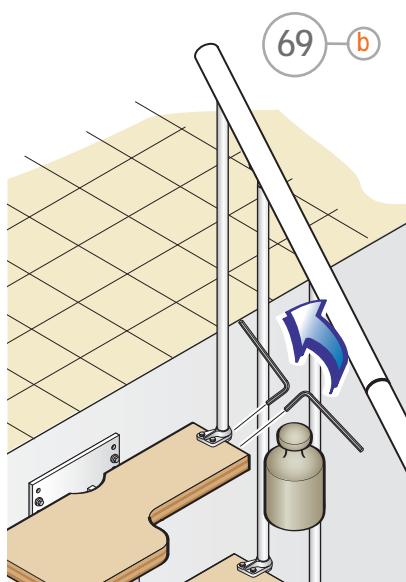
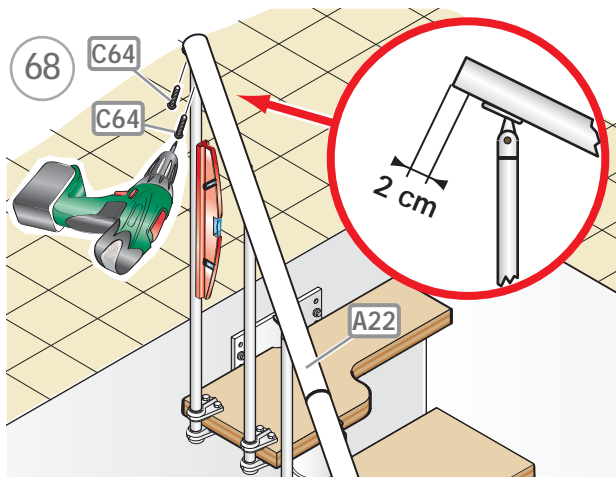

70

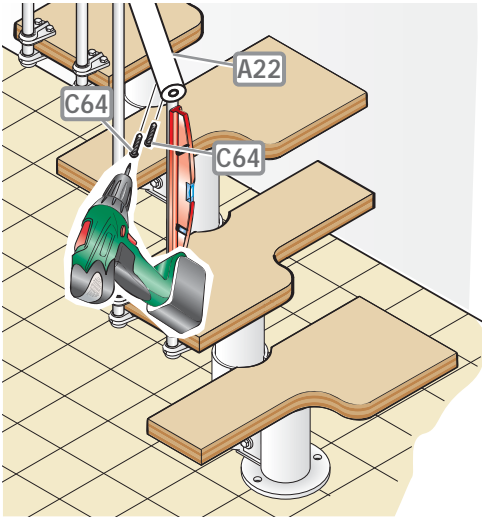

71 b

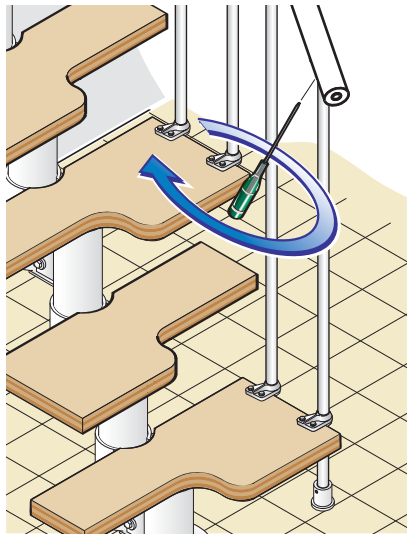

72 b

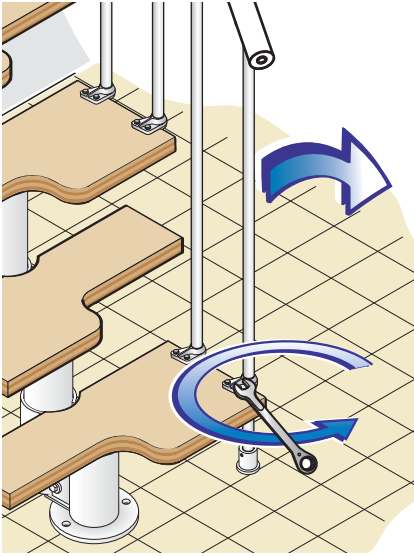

73

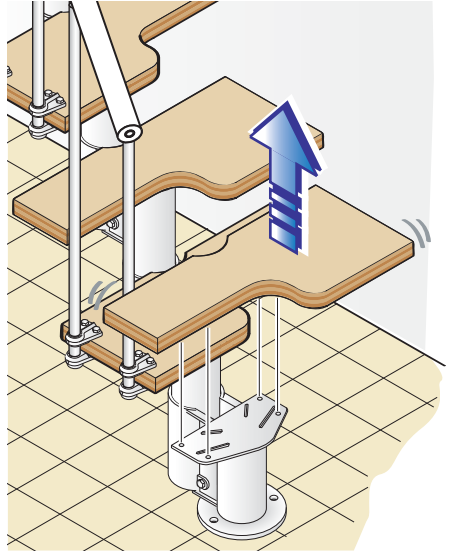

74

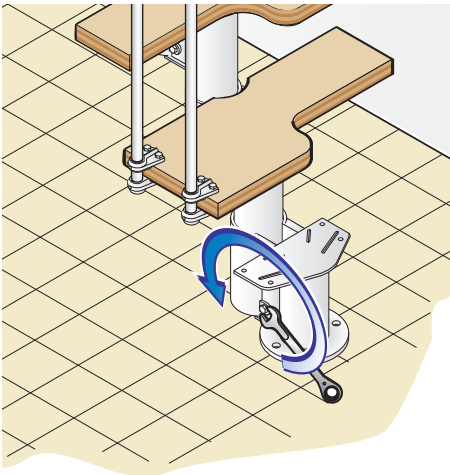

75

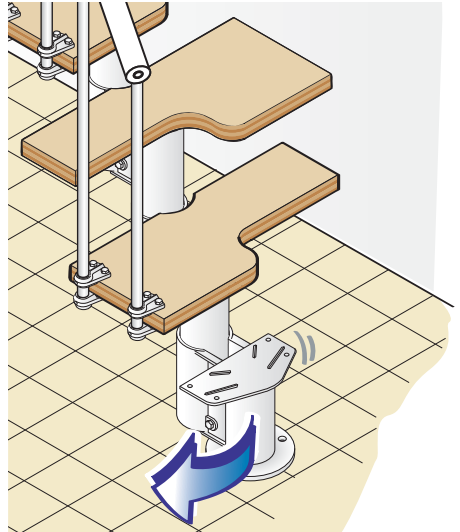

76 b

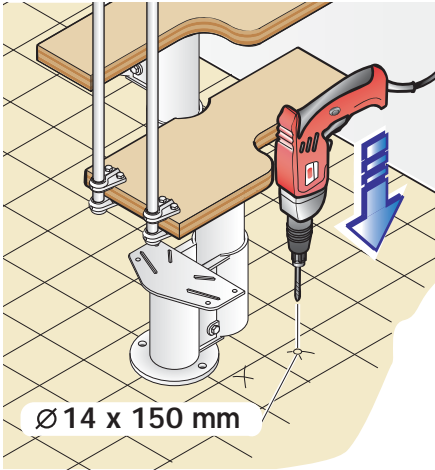

77

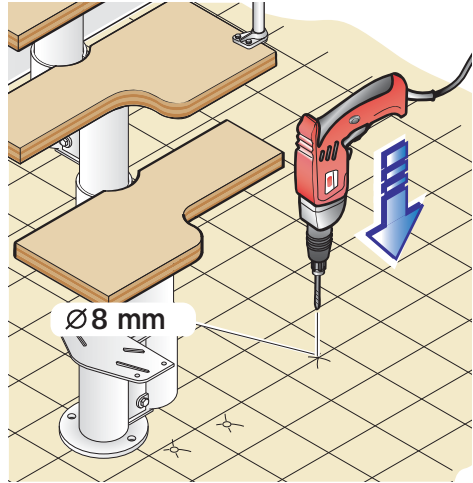

78

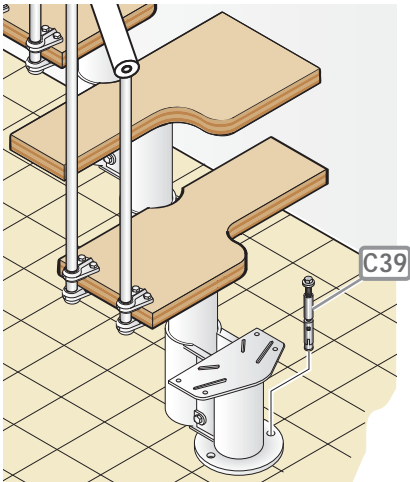

79

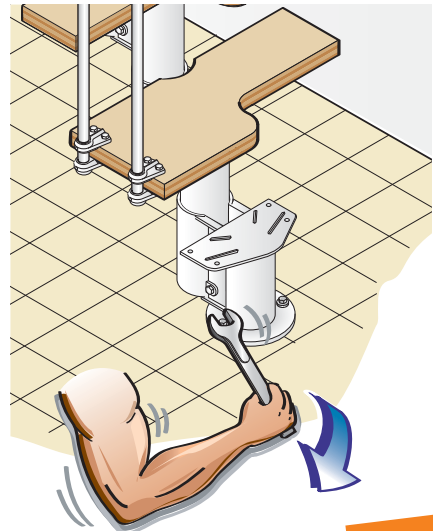

80



81 b

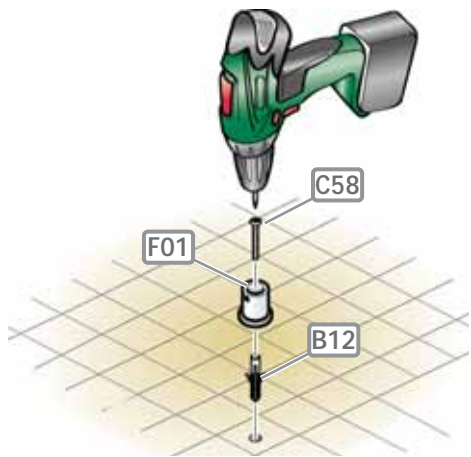

82

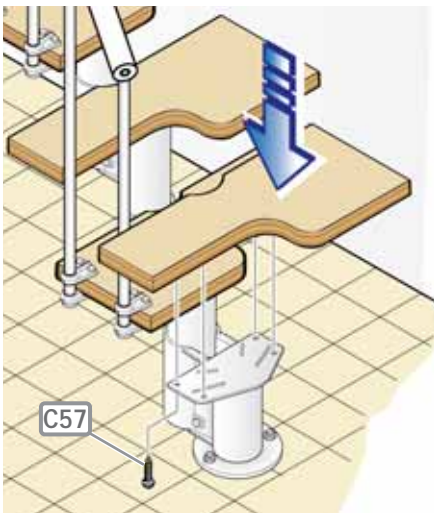

83 b

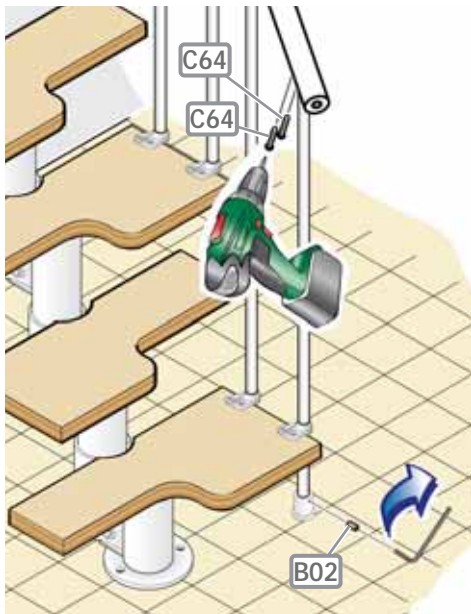

84 b

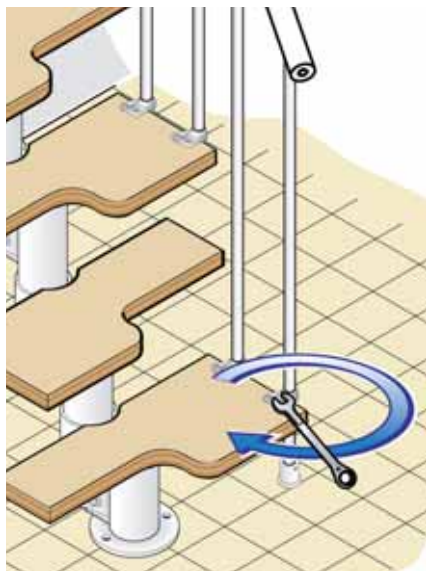

85 b

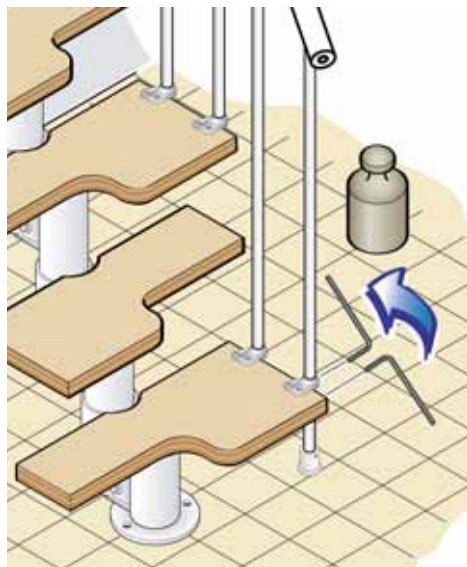

86

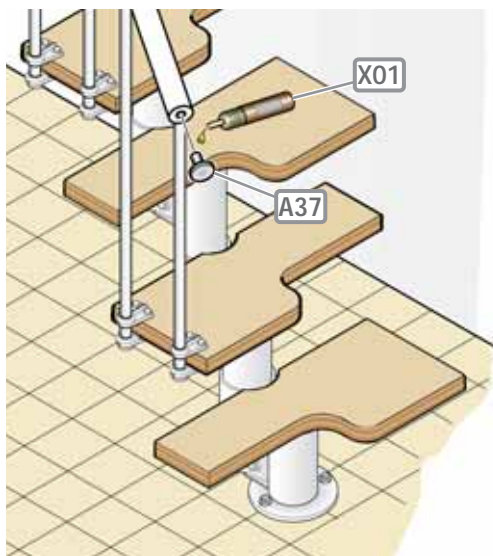

87

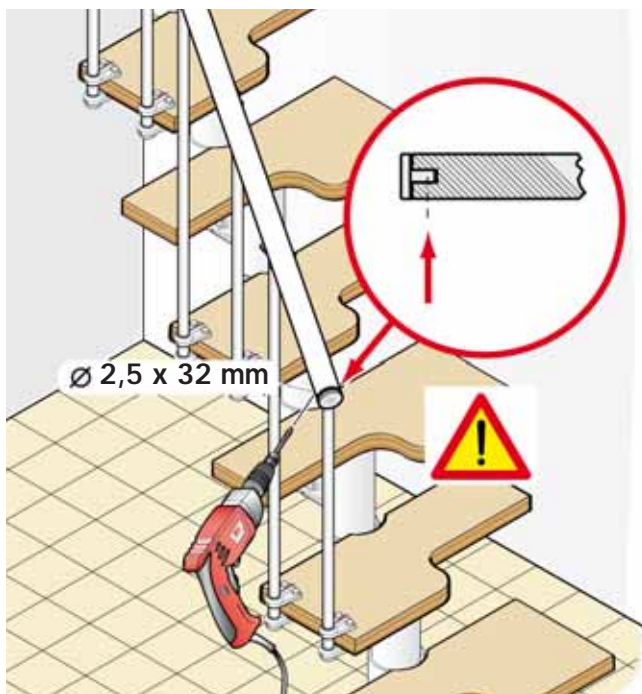

88

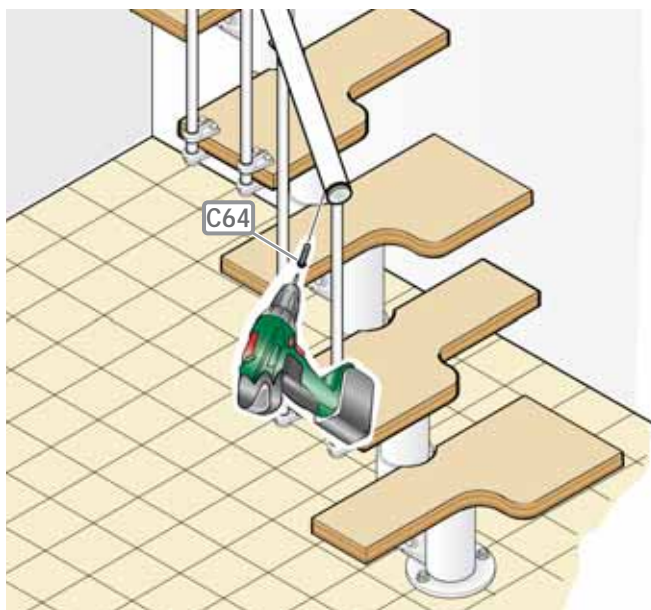

89

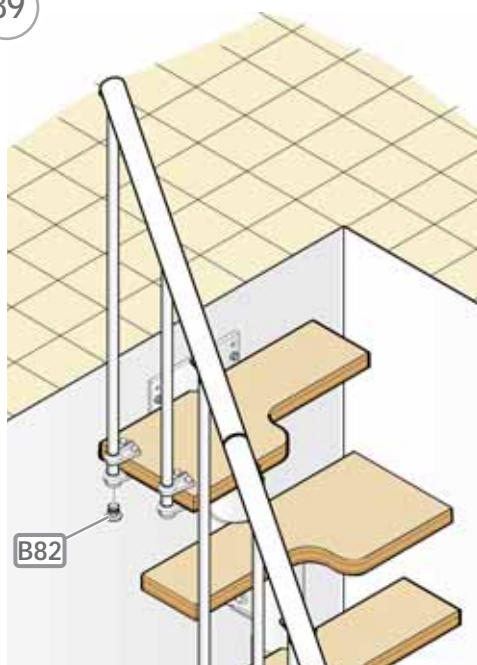

90

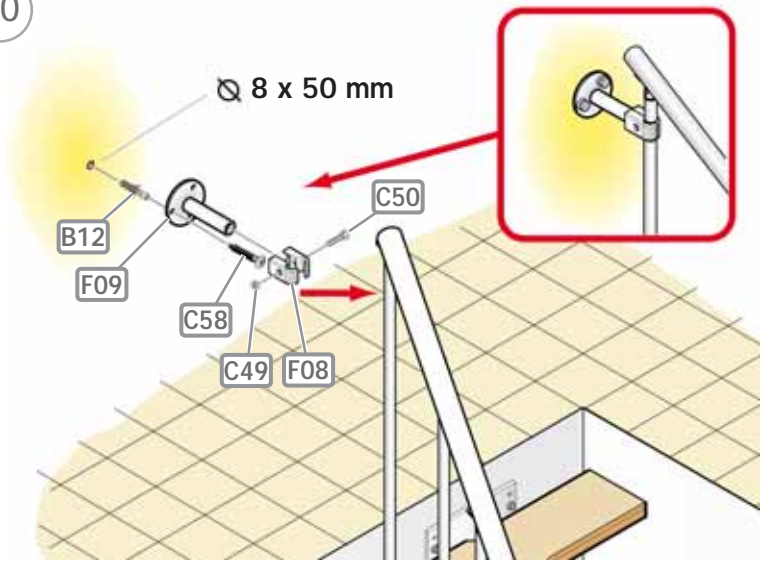

91

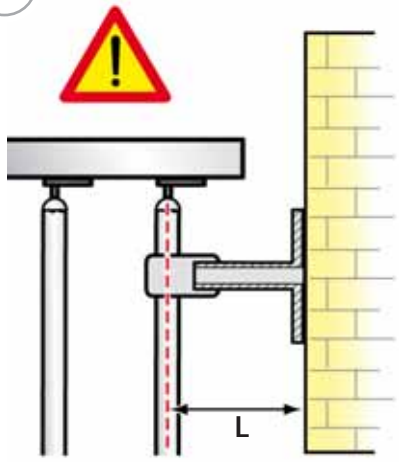

92

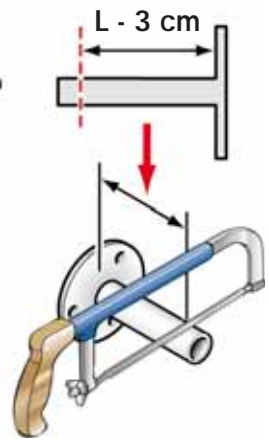



Italiano
English
Deutsch
Français
Español

DATI IDENTIFICATIVI DEL PRODOTTO
PRODUCT DETAILS
PRODUKTEIGENSCHAFTEN
DONNÉES D'IDENTIFICATION DU PRODUIT
DATOS DE IDENTIFICACIÓN



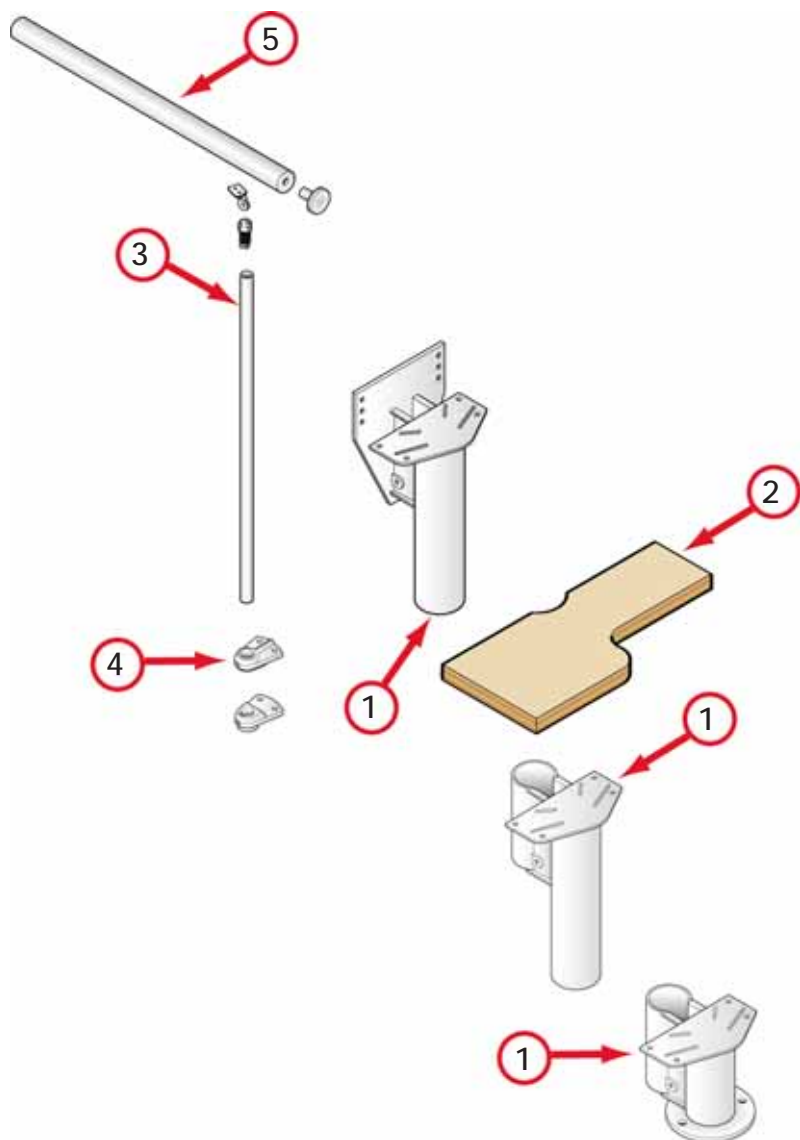

IT)

dati identificativi del prodotto

denominazione commerciale: **MAGIA 30**
tipologia: scala a giorno con gradini sfalsati e rotazione delle rampe con pendenza

materiali impiegati

STRUTTURA

descrizione

composta da elementi (1) metallici assemblati fra di loro con bulloni

materiali

Fe 370

finitura

verniciatura a forno con polveri epossidiche

GRADINI

descrizione

gradini (2) in legno sagomati assemblati alla struttura con bulloni

materiali

multistrato di betulla

finitura

tinta: all'acqua

fondo: poliuretano

finitura: poliuretano

RINGHIERA

descrizione

composta da colonnine (3) verticali in metallo fissate ai gradini (2) e da corrimano (5) in PVC

materiali

colonnine (3): Fe 370

fissaggi (4): nylon

corrimano (5): PVC con anima di alluminio

finitura

colonnine (3): verniciatura a forno con polveri epossidiche

PULIZIA E MANUTENZIONE OBBLIGATORIA

Eseguire la pulizia della scala alla prima comparsa di macchie di sporco e depositi di polvere e periodicamente almeno ogni 6 mesi con panno morbido inumidito in acqua e detersivi specifici non abrasivi ed aggressivi. NON usare mai pagliette abrasive o in ferro. Pulire ed asciugare accuratamente dopo il lavaggio con un panno in microfibra al fine di eliminare gli aloni del calcare presente nell'acqua.

Dopo circa 12 mesi dalla data di installazione, controllare il serraggio della viteria dei vari componenti. Al verificarsi di qualsiasi minimo malfunzionamento è obbligatorio effettuare una manutenzione straordinaria, da eseguire subito e a regola d'arte.

PRECAUZIONI D'USO

Evitare usi impropri e non consoni al prodotto. Eventuali manomissioni o installazioni non rispondenti alle istruzioni del produttore possono incidere le conformità prestabilite del prodotto.

EN)

product details

trade name: **MAGIA 30**
type: flight staircase with alternate treads and flight rotation with slope

used materials

STRUCTURE

description

composed of metallic elements (1) assembled between themselves by bolts

materials

spacers: Fe 370

finishing

oven varnishing with epoxy powders

TREADS

description

wooden shaped treads (2) assembled to the structure by bolts

materials

birch plywood

finishing

colour: water-base

undercoat: polyurethane

finishing: polyurethane

RAILING

description

composed by vertical metal balusters (3) fixed to the treads (2) and by a PVC handrail (5)

materials

balusters (3): Fe 370

fixings (4): nylon

handrail (5): PVC with aluminium core

finishing

balusters (3): oven varnishing with epoxy powders

OBLIGATORY CLEANING AND MAINTENANCE

Clean the treads as soon as dirt spots and dust deposits appear and at least every 6 months using a soft cloth moistened with water and specific non-abrasive and non-aggressive detergents. NEVER use abrasive scourers. After cleaning, thoroughly dry the surfaces with a microfibre cloth to remove the haloes that form because of the limestone in the water. Approximately 12 months from the date of installation, check tightness of the screws of the various components. Should even the smallest malfunction occur, it is obligatory to immediately and professionally carry out extraordinary maintenance.

USE PRECAUTION

Avoid any improper use that is not in accordance with the product. Possible violations or installations which don't comply with the providers instructions can invalidate the agreed product conformities.

DE)

Produkteigenschaften

kommerzielle Bezeichnung: **MAGIA 30**

Typologie: Mittelholttreppe mit versetzten Stufen, Wendelung der Treppenläufe mit Neigung

verwendete Materialien

STRUKTUR

Beschreibung

bestehend aus Metallteilen (1) die miteinander durch Bolzen verbunden sind

Materialien

Fe 370

Ausführung

Pulverbeschichtung mit Epoxidharzen

STUFEN

Beschreibung

geformte Stufen (2) aus Holz an der Struktur mittels Bolzen befestigt

Materialien

Mehrschichtbirkenholz

Ausführung

Beizung: Wasserfarbe

Grundierung: Polyurethan

Oberlack: Polyurethan

GELÄNDER

Beschreibung

bestehend aus senkrechten Geländerstäben (3) aus Metall, die an den Stufen (2) befestigt sind, und einem Handlauf (5) aus PVC

Materialien

Geländerstäbe (3): Fe 370

Befestigungen (4): Nylon

Handlauf (5): PVC mit Aluminiumkern

Ausführung

Geländerstäbe (3): Pulverbeschichtung mit Epoxidharzen

REINIGUNG UND VORGESCHRIEBENE INSTANDHALTUNG

Die Treppe sofort reinigen wenn Schmutzfl ecken und Staubansammlungen entstehen und sie mindestens alle 6 Monate mit einem weichen, mit Wasser und einem spezifischen, weder scheuernden, noch aggressiven Reinigungsmittel befeuchteten Lappen abzuwischen. NIEMALS scheuernde Eisenschwämme verwenden.

Nach der Feuchtreinigung mit einem Mikrofasertuch sorgfältig nachtrocknen, um die Schlierenbildung durch kalkhaltiges Wasser zu vermeiden. 12 Monate nach der Montage das Anzugsmoment der Schrauben der verschiedenen Komponenten kontrollieren. Bei Auftreten einer noch so geringen Funktionsstörung muss unbedingt sofort eine fachgerechte außerordentliche Instandhaltung durchgeführt werden.

VORSICHTSMAßNAHMEN FÜR DIE ANWENDUNG

Die falsche und unangemessene Verwendung des Produkts vermeiden. Eventuelle Beschädigungen oder nicht der Montageanleitung des Herstellers gemäße Einrichtungen können die vorgegebene Produktkonformität für ungültig erklären.

FR)

données d'identification du produit

denomination commerciale : **MAGIA 30**

typologie : escalier à volée avec marches décalées et rotation des volées en pente

matériaux utilisés

STRUCTURE

description

composée d'éléments (1) métalliques assemblés entre eux par boulonnage

matériaux

Fe 370

finition

vernissage à chaud avec poudres époxy

MARCHES

description

marches façonnées (2) en hêtre massif assemblées à la structure par boulonnage

matériaux

multipli de bouleau

finition

vernis : à l'eau

mordant : polyuréthanique

finition : polyuréthanique

GARDE-CORPS

description

composé de colonnettes (3) verticales en métal fixées aux marches (2) et d'une main courante (5) en PVC

matériaux

colonnettes (3) : Fe 370

fixations (4) : nylon

main courante (5) : PVC avec noyau en aluminium

finition

colonnettes (3) : vernissage à chaud avec poudres époxy

NETTOYAGE ET MAINTENANCE OBLIGATOIRE

Nettoyer les marches dès que des taches de saleté ou des dépôts de poussière apparaissent ; effectuer également un nettoyage périodique, tous les 6 mois, à l'aide d'un chiffon doux, humidifié d'eau et de détergents spécifiques non abrasifs et non agressifs. NE JAMAIS utiliser de la paille de fer abrasive. Après lavage, nettoyer et essuyer soigneusement avec un chiffon en microfibre, afin d'éliminer les auréoles provoquées par le calcaire contenu dans l'eau. Environ 12 mois après la date d'installation, contrôler le serrage des vis des différents composants. À la moindre défaillance, il est obligatoire d'effectuer immédiatement une maintenance corrective, dans les règles de l'art.

PRECAUTION D'UTILISATION

Eviter l'utilisation impropre et non conforme au produit. D'éventuelles alterations ou installations non correspondantes aux instructions du producteur peuvent invalider les conformités préétablies du produit.

ES)

datos de identificación del producto

denominación comercial: **MAGIA 30**

tipo: escalera abierta con peldaños de paso alternado y rotación de los tramos con pendiente

materiales empleados

ESTRUCTURA

descripción

compuesta por elementos (1) metálicos ensamblados entre ellos mediante pernos

materiales

Fe 370

acabado

barnizado en horno con polvos epoxídicos

PELDAÑOS

descripción

peldaños (2) de madera perfilados y ensamblados a la estructura mediante pernos

materiales

multicapa de abedul

acabado

barniz: al agua

imprimación: poliuretánica

acabado: poliuretánico

BARANDILLA

descripción

compuesta por barrotes (3) verticales de metal fijados a los peldaños (2) y por un pasamanos (5) de PVC

materiales

barrotes (3): Fe 370

fijaciones (4): nylon

pasamanos (5): PVC con alma de aluminio

acabado

barrotes (3): barnizado en horno con polvos epoxídicos

LIMPIEZA Y MANTENIMIENTO OBLIGATORIO

Realizar la limpieza de la escalera en cuanto aparezcan manchas de suciedad y depósitos de polvo, y periódicamente al menos cada 6 meses, con un paño suave humedecido en agua y detergentes específicos no abrasivos ni agresivos. NO utilizar nunca lanas abrasivas o de hierro. Limpiar y secar bien después del lavado utilizando un paño de microfibra para eliminar las aureolas de cal dejadas por el agua.

Transcurridos unos 12 meses desde la fecha de instalación, comprobar que los tornillos que fijan las distintas partes sigan bien apretados.

Ante el menor defecto de funcionamiento, es obligatorio realizar un mantenimiento extraordinario según las reglas del arte.

PRECAUCIONES DE USO

Evitar usos impropios y no conformes con el producto.

Eventuales manipulaciones o instalaciones que no cumplan con las instrucciones del fabricante pueden menoscabar las cualidades certificadas en las pruebas de conformidad a las que previamente fue sometido el producto.



30
D.U.M.
07/2016



Fontanot S.p.A.
Sede legale ed amministrativa
via P. Paolo Pasolini, 6
47853 Cerasolo Ausa
Rimini, Italy

tel. +39.0541.90.61.11
fax. +39.0541.90.61.24
info@fontanot.it
www.fontanot.it

cod. 065940000

Design: Centro Ricerche Fontanot

Sistema aziendale Fontanot S.p.A.
certificato CSQ ISO-9001

